

RADIO CONTROLLED ELECTRIC POWERED SPECIAL RACING BUGGY
4WD OFF-ROAD RACER

OPTIMA MID CUSTOM SPECIAL

- COMPETITION LONG WHEEL BASE VERSION OF OPTIMA MID.
- FOUR-WHEEL DRIVE BY LIGHT, RELIABLE, EFFICIENT TOOTHED BELT.
- TOP-QUALITY OIL FILLED SHOCK ABSORBERS.
- FULL SET OF BALL BEARINGS (16).
- DIFFERENTIAL GEARS HAVE BEEN INSTALLED INSIDE BOTH THE FRONT AND REAR GEAR BOX.
- EQUIPPED WITH DOUBLE WISHBONE 4 WHEEL INDIVIDUAL SWINGING ARM SUSPENSIONS.
- MOTOR: Le MANS 240/360 TYPE, BATTERY 7.2V-1200/1700mAh NiCd BATTERY.(NOT INCLUDED)
- RADIO: 2 CHANNEL RADIO CONTROL SYSTEM FOR ELECTRIC SPEED CONTROLLER SPECIFICATION.
(NOT INCLUDED)

1:10 SCALE

BELT DRIVE
4WD

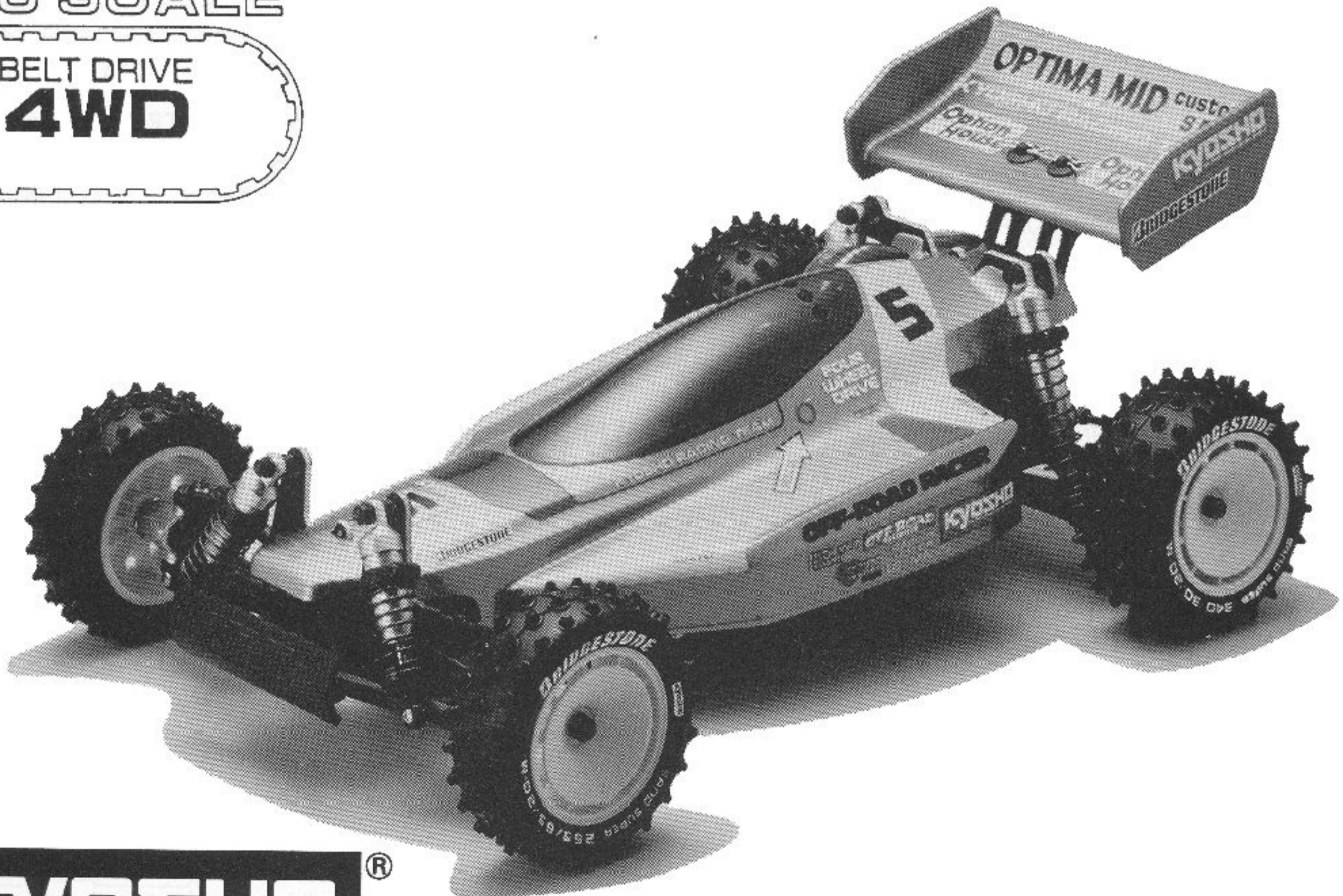

KYOSHO®
THE FINEST RADIO CONTROL MODELS

KIT NO.3140FG

BEFORE YOU BEGIN ASSEMBLY!

Thank you for purchasing the Kyosho's R/C "1/10 EP 4WD Off-Road Racer OPTIMA MID CUSTOM SPECIAL"

In order to keep your Optima Mid Custom Special in top condition to enjoy the most pleasure from the R/C world, you should thoroughly read this instruction manual and the operation instruction of the radio control units to keep the correct way of assembling.

- New type Aero-body with excellent aerodynamic characteristics. Equipped with Under-cowl to prevent dirt and pebbles entering inside.
- Stylish Aero type wheels adopted bright fluorescent yellow for easy tracking while running.
- Top quality oil filled shock absorbers.
- Equipped with ball bearings in all the main driving areas. (With 16 pcs. Full Bearing)

Before You Begin Assembly.....	2
Before Assembly	3
Bagged Parts List (1)	4
Bagged Parts List (2)	5
Layout Drawing of Plastic Parts on Runners	6

● ASSEMBLY OF CHASSIS PORTION

1 ~ 30

1 ASSEMBLY OF RODS	7
2 ASSEMBLY OF REAR GEAR BOX	8
3 INSTALLATION OF REAR PLATE	9
4 INSTALLATION OF SPUR GEAR	9
5 INSTALLATION OF REAR SHOCK STAY	9
6 ASSEMBLY OF FRONT GEAR BOX	10
7 INSTALLATION OF GEAR BOX	10
8 INSTALLATION OF REAR SUSPENSION ARM	11
9 INSTALLATION OF UPPER CHASSIS PARTS	11
10 INSTALLATION OF BATTERY HOLDER	11
11 ASSEMBLY OF KNUCKLE ARM	12
12 INSTALLATION OF FRONT SUSPENSION ARM	12
13 ASSEMBLY OF FRONT UPPER ROD	12
14 INSTALLATION OF REAR HUB	13
15 INSTALLATION OF REAR UPPER ROD	13
16 ASSEMBLY OF SERVO SAVER	13
17 INSTALLATION OF SERVO SAVER	14
18 INSTALLATION OF TIE ROD	14
19 DISASSEMBLY OF SHOCK	14
20 ASSEMBLY OF SHOCK	15
21 FILLING THE SHOCK OIL	15
22 INSTALLATION OF SHOCK	15

23 INSTALLATION OF UPPER DECK	16
24 INSTALLATION OF BELT COVER (B),(C)	16
25 CHECKING THE BELT COVER	17
26 INSTALLATION OF MOTOR CORD	17
27 INSTALLATION OF MOTOR	17
28 INSTALLATION OF WING STAY	18
29 ASSEMBLY OF TIRE AND WHEEL	18
30 INSTALLATION OF TIRE	18

● INSTALLATION OF R/C UNIT AND LINKAGE

31 ~ 35

31 CHECK THE RADIO SYSTEM	19
32 INSTALLATION OF STEERING SERVO AND LINKAGE	19
33 INSTALLATION OF SPEED CONTROL AMP	20
34 INSTALLATION OF SWITCH AND RECEIVER	21
35 INSTALLATION OF BATTERY	21

● CUTTING AND INSTALLATION OF BODY

36 ~ 39

36 CUTTING OF BODY, UNDER COWL AND WING	22
37 PAINTING	22
38 APPLYING DECALS	23
39 INSTALLATION OF UNDER COWL, BODY AND WING	23
GUIDE FOR SET UP (1)	24
GUIDE FOR SET UP (2)	25
KEY NUMBERS FOR PARTS	26
PURCHASABLE PARTS FOR YOUR KIT	27
EXPLODED VIEW	28
EXPLODED VIEW	29

BEFORE ASSEMBLY

*Read the instruction carefully.
You can assemble the kit more easily if you have grasped the general idea of steps and structure beforehand by reading it through to the end.



*Check the parts in the kit.
Check to see if all the parts are correctly bagged as they are listed in the "List of Bagged Parts". Your thorough understanding of the assembly will enable you to build the kit without any difficulty. Check the components in the kit prior to your starting of the assembly.



Any claims for replacements or refunds for the model in the process of assembly will not be accepted.

*Learn the marks described in the instruction.

SW-CEMENT ...Place to put some locktite.

It will prevent the screws and nuts get loosen by vibration whilerunning.

GREASE ... Point where grease should applied.

It will reduce friction are assure smooth movement.



Steps where your particular attention is required.

*Be well aware of the different types of screws.

1 The difference between the TP Screw (short form of self-tapping screw) and the ordinary screw is...

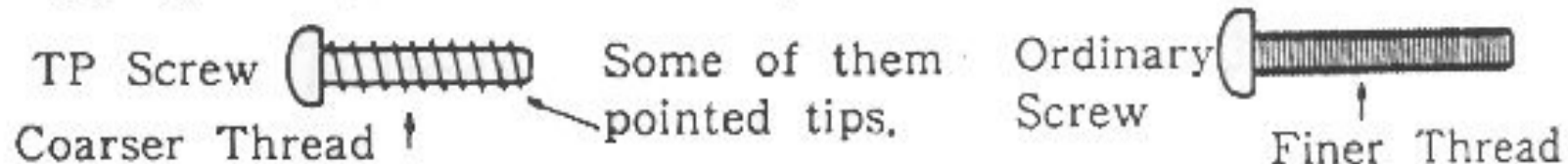

2 The kinds of screws which will be used in the instruction.



There are two kinds of thread, finer and coarser ones.

3 Pick up the correct parts and screw.
Compare the shape and size of small parts, such as screws, nuts, and washers with the actual size drawing of each step.

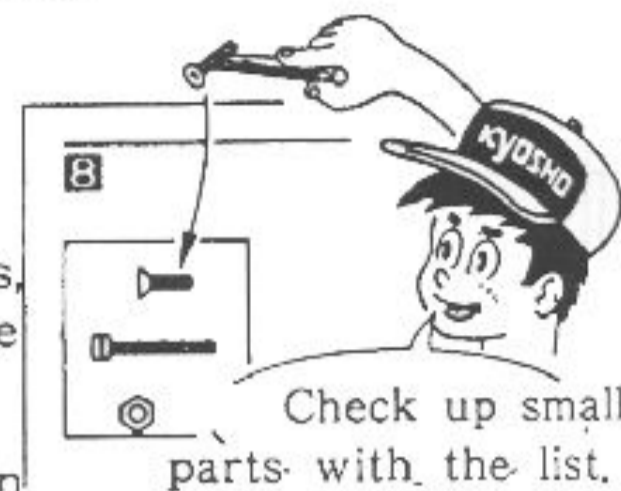

4 Be sure about the location and direction of parts to install.

Double-check the location and orientation of parts with the illustration before installation. When necessary, assemble the parts themselves tentatively before proceeding to the next step.



5 Do not tighten the self-tapping screw too tight.

Do not use excessive force when tightening the self-tapping screws, or you may strip the thread in the plastic.

It is recommended to stop tightening it when the thread part on the screw goes into the plastic part and you feel some resistance from the tightening.

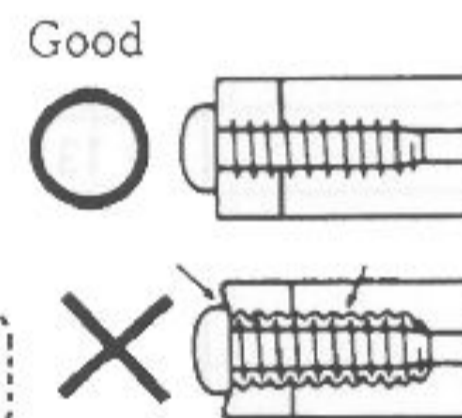

*Things need beside the kit.

(2 Channel Radio System)

Two types of radio control set are on the market, the stick type and the steering wheel type. Choose which ever you like.

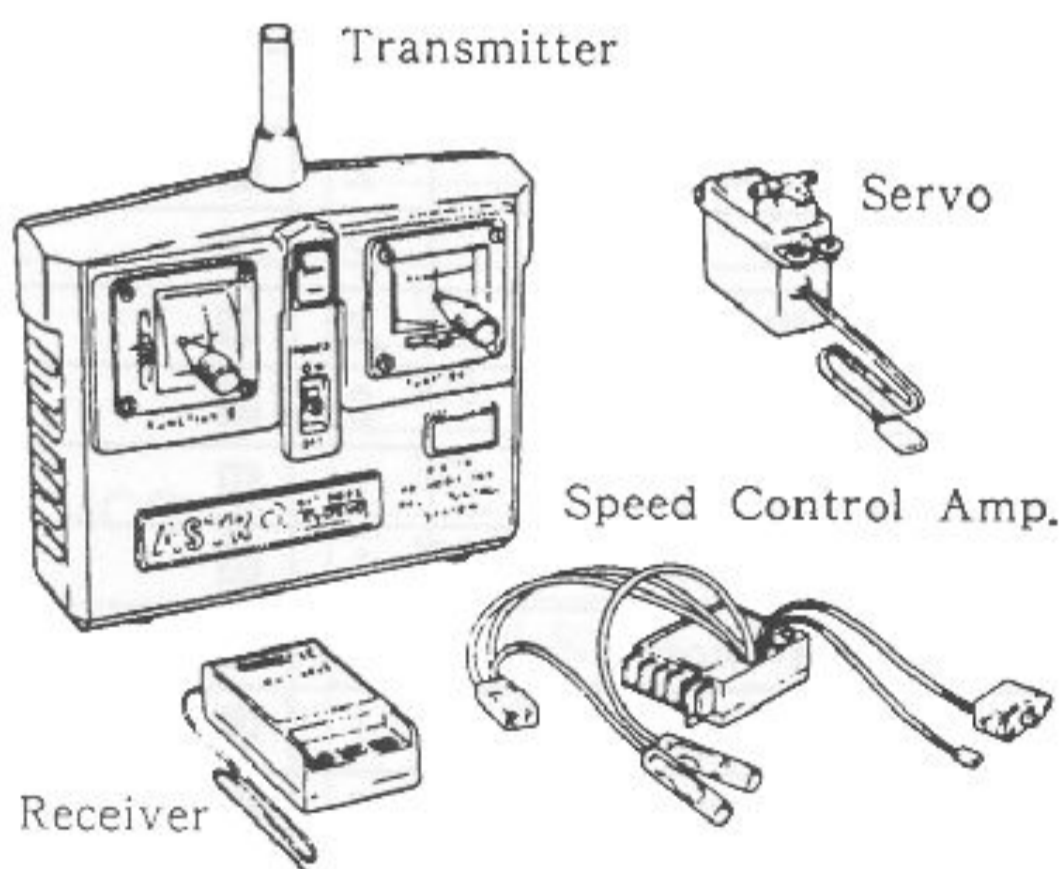

(Battery for Radio System)

For Transmitter
.....8 pcs.

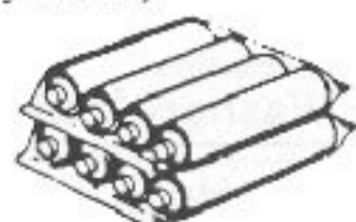

(Ni-Cd Battery)

"Optima Mid Custom Special" is designed to use a rechargeable 7.2V Ni-Cd Battery pack. 7,2V Sprint Battery and 7,2V SCR Saddle Pack Battery are ideal for the purpose.

NO.2331 7.2V-1200mA SCR Saddle Pack

NO.2310 7.2V-1200mA Sprint Battery SCR

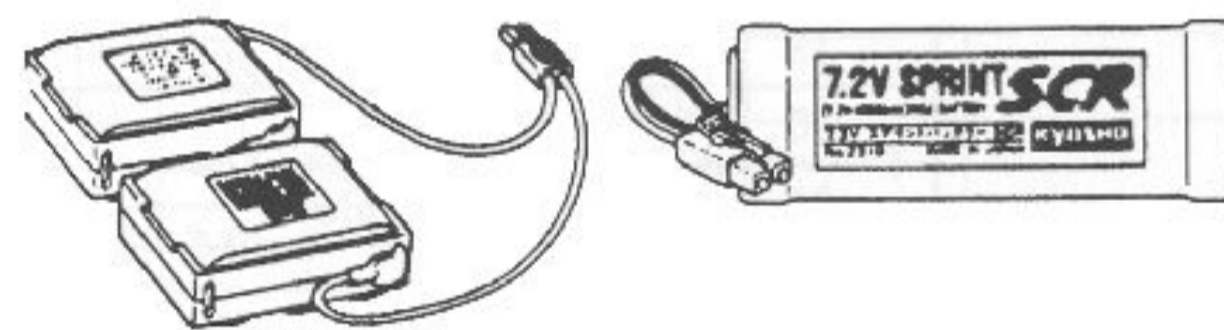

(Motor)

The Optima Mid Custom Special not come with a motor. A Le Mans series type motor is recommended for top performance.

NO, 1986 Le Mans Speed 240T
1926 Le Mans H-240S
1925 Le Mans 360G
W1011 SPA 240WS

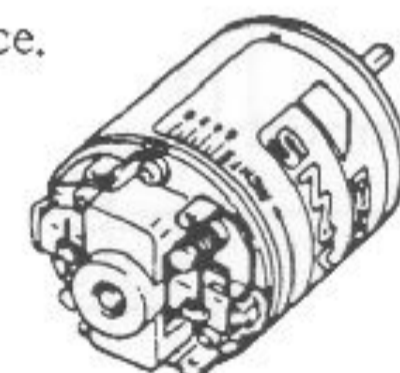

(Charger for Ni-Cd Battery)

The Kyosho's Ni-Cd battery is of high performance. If it is charged correctly, it will operate for a considerable period of time.

*Use one of the Chargers listed below which suits your need.

NO.	Name	Time	Rate	Features
2326	7.2V Power Charger (DC12V)	15 min.	70%	For Biginners Built-in timer
1845	Lambda Quick Charger (DC12V)	20 min.	100%	Trickle charging Automatic cut-off at peak of charge
1849	Multi Charger II (DC12V)	20 min.	100%	Timer, Ammeter built-in

(Tools Required) A Hex Key, Grease and SW-cement are included in the kit.

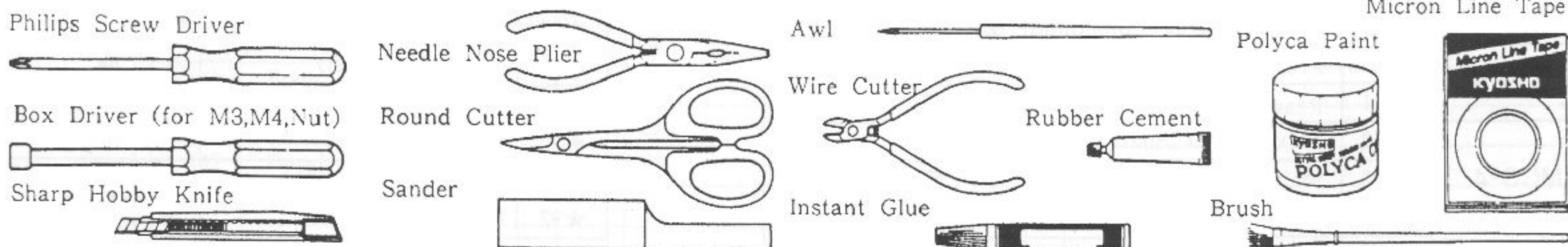

LIST OF BAGGED PARTS (1) The key numbers with ★ indicated plastic parts on a runner. See page 6 for the

⟨Do not throw away a bag header⟩

- The symbol in the round brackets after the name of parts in this instruction means the header number of the bag in which the part is contained.
- The header is the only thing to rely upon when looking for a part. Do not discard it until you finish the assembly.

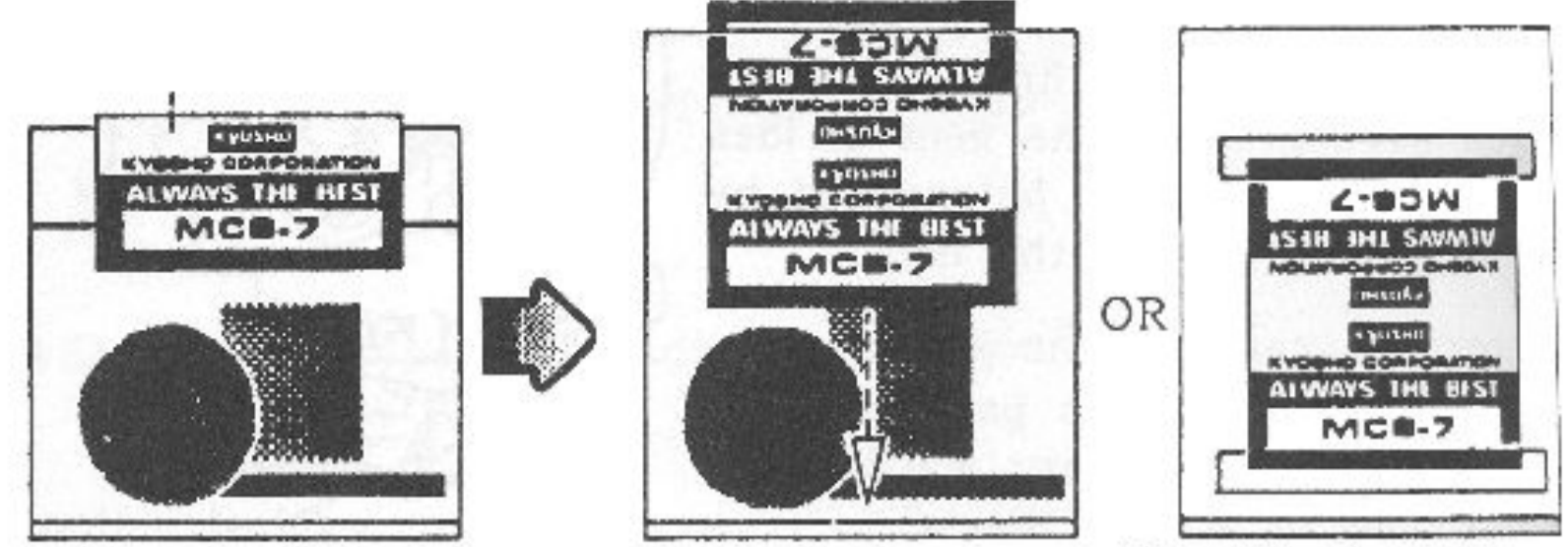

After remove the header cards.

Keep it in the bag.

OR Or affix it on the bag with tape.

Bag No.	Key #	Name	Qty	Step	
Blister (A)	● 1	Front Shock Shaft	2		
	● 2	Rear Shock Shaft	2		
	● 3	Front Shock Case	2		
	● 4	Rear Shock Case	2		
	● 5	Front Shock Spring	2		
	● 6	Rear Shock Spring	2		
	● 7	Spring Holder	4		
	● 8	Shock Cap	4	10	
	● 9	Spring Stopper	4		
	● 10	Shock End	4		
	● 143	E Ring (E2.5)	4		
	⊙ 11	Front Differential Case	1		
	⊙ 12	Rear Differential Case	1		
	⊙ 13	Sprocket	2	⊙	
	⊙ 14	Differential Ring (Yellow)	2		
	⊙ 15	Bevel Gear (A)	4		
	⊙ 16	Bevel Gear (B)	4		
	⊙ 17	Bevel Shaft	2	2	
	⊙	M2x12 TP Screw	8		
	18	Drive Washer	4	30	
	19	Joint	4	2	
	20	Pinion Gear (20) T	1	77	
	21	Main Gear Pinion	1	2	
	22	Main Gear	1	4	
23	Center Gear	1	2		
24	Toothed Belt	1	2		
Blister (B)	25	8 φ x14 Bearing	4	2	
	26	5 φ x10 Bearing	10	2 11 14	
	27	4 φ x8 Bearing	2	2	
	110	Main Chassis	1	7	
MCS-2	28	Front Gear Box (R)	1	6	
	29	Front Gear Box (L)	1	6	
	30	Rear Gear Box (R)	1	2	
	31	Rear Gear Box (L)	1	2	
	32	Sponge Tape	2	8	
	33	Rubber Cover	1	24	
	34	Steering Rod	1	1 45mm	
	35	Double Sided Tape	1	33 34 39	
	36	Shock Oil (Green)	1	21	
	37	Strap (S)	3	33 34	
	38	Silicone Grease	1		
	39	Screw Locking Compound	2		
	MCS-3	40	Front Wheel	2	74
		41	Rear Wheel	2	29
	MCS-4	42	Servo Saver Shaft	2	9
43		Main Gear	1	2	
44		Gear Protector Plate (B)	1	4	
45		Gear Protector Collar	1	4	

Bag No.	Key #	Name	Qty	Step	
MCS-4	46	Center Gear Shaft	1	2	
	47	Gear Protector Washer	2	4	
	48	King Pin	4	11	
	49	5.8 φ Ball (Black)	4	1	
	50	2 φ x11 Pin	2	2	
	51	Upper Deck Post	2	9	
	52	Rear Wheel Shaft	2	14	
	53	Ball Nut	3	10	
	MCS-5	54	Rear Plate (R)	1	3
		55	Front Shock Stay	1	6
		56	Rear Shock Stay	1	5
57		Rear Upper Plate	1	5	
58		Rear Suspension Plate	1	8	
59		Front Suspension Plate	1	6	
60		Gear Protector Plate (A)	1	4	
61		Motor Plate	1	77	
MCS-6 Plastic Parts		★62	Pully Flange (Yellow)	1	2
		★63	5 φ Collar (L) (Yellow)	1	4
	★64	5 φ Collar (S) (Yellow)	2	2 spare x 1	
	★65	Pully (Yellow)	1	2	
	★66	Wing Stay (A) (R)	1	28	
	★67	Wing Stay (A) (L)	1	28	
	★68	Wing Stay (B)	2	28	
	★69	Wing Stay Joint	2	28	
	★70	Wing Washer	4	39 spare x 2	
	★71	Battery Holder	2	10	
	★72	Servo Spacer	2	33	
	★73	Front Stabilizer End	2	12	
	★74	Servo Stay Spacer	2	17	
	★75	Switch Holder	1	34	
	★76	Rear Suspension Holder	1	8	
	★77	Upper Deck Mount	1	9	
	★78	Belt Cover Stopper	1	9	
	★79	Battery Stopper	2	35	
	★80	Stopper Post	4	10	
	★81	Stopper Washer (Thin)	4		
	★82	Stopper Washer (Thick)	4	10	
	★83	Front Body Hook	2	30	
	★84	Rear Body Hook (R)	1	30	
	★85	Rear Body Hook (L)	1	30	
★86	Belt Cover (C)	1	24		
★87	Servo Saver (A)	1	16		
★88	Servo Saver (B)	1	16		
★89	Servo Saver (C)	1	16		
★90	Servo Saver (D)	1	16		
★91	Servo Saver Collar	2	17		
★92	M3 Plastic Nut	6	22 spare x 2		
★93	Servo Stay	4	17 33		

LIST OF BAGGED PARTS (2)

Bag No.	Key #	Name	Qty	Step	
MCS-6 Plastic Parts	★ 94	Shock Collar	4	22	
	★ 95	Antenna Post	1	17	
	★154	Servo Stay Collar	2	33	
	96	Bumper	1	13	
	97	Front Hub (R)	1	11	
	98	Front Hub (L)	1	11	
	99	Rear Hub (R)	1	14	
	100	Rear Hub (L)	1	14	
MCS-7	101	Front Sus.Shaft(A)Silver	2	12	
	102	Front Sus.Shaft (A)Black	2	14	
	103	M3 Pillow Ball (Silver)	4	12 14	
	104	M3 Pillow Ball (Black)	4	11 16	
	105	5.8 φ Ball (Silver)	4	1	
	106	Ball End (L)	12	1	
	107	Ball End (S)	3	1 16	
	108	Front Suspension Shaft B	2	12 54mm	
	109	Rear Suspension Shaft B	2	8 58mm	
MCS-8	111	Upper Deck	1	23	
	112	Belt Cover (A)	1	7	
	113	Belt Cover (B)	1	24	
	114	Gear Cover	1	3	
	115	One Touch Tape	4	7	
	116	Motor Cord (Red.White)	1	26	
	117	Front Suspension Arm	2	12	
	118	Rear Suspension Arm	2	8	
	119	Antenna Pipe	1	34	
	120	Knuckle Arm (R)	1	11	
	121	Knuckle Arm (L)	1	11	
	122	Saver Spring	1	16	
	123	Cemical Condencer	1	26	
	124	Rear Plate (L)	1	3	
	125	5 φ x8 Metal	2	2 Small Bag	
	126	Ni-Cd Strap	2	39	
	MCS-9 Small Bag	127	3 φ x32 Adjust Rod	4	1
		128	3 φ x50 Adjust Rod	2	1
129		Universal Swing Shaft	2	11	
130		Swing Shaft	2	19	
★131		Shock Piston	4	20	
132		Shock Collar (White)	4	20	
133		Shock Collar (Black)	4	20	
134		Pressure Top	4	21	
135		O Ring (P3.Red)	8	20	
136		C Ring	8	20 Spare x 4	
Box	137	Front Tire	2	29	
	138	Rear Tire	2	29	
	139	Wing	1	36	
	140	Body	1	36	
	141	Under Cowl	1	36	
	142	Decal	1	38	
		Instruction	1		

Bag No.	Key #	Name	Qty	Step
MCS-1 Screws, Nuts, Washers & Others,	143	E Ring (E2.5)	13	8 12 14 Spare x1
	144	E Ring (E3) (Black)	3	12
	145	E Ring (E4)	5	2 17
	146	M2x10 Shaft	2	16
	147	5 φ Shim	8	4 17 30
	148	Wave Washer	3	4
	149	Hook Pin	11	37 39 Spare x1
	150	Body Pin	2	39
	151	Allen Wrench (1.5mm)	1	27
	152	Allen Wrench (2mm)	1	2
	153	Allen Wrench (2.5mm)	1	5 6
		M2,6x4 Bind Screw	4	
		M2,6x6 Bind Screw	1	
		M2,6x12 Bind Screw	4	
		M3x6 Bind Screw	2	
		M3x10 Bind Screw	4	
		M3x30 Bind Screw	2	
		M3x35 Bind Screw	1	
		M3x45 Bind Screw	2	
		M4x12 Bind Screw	2	
		M3x4 Screw	2	
		M3x6 Flat Head Screw	4	
		M3x12 Flat Head Screw	2	
		M2,6x6 TP Bind Screw	6	
		M2,6x12 TP Bind Screw	4	
		M3x6 TP Bind Screw	3	
		M3x10 TP Bind Screw	19	
		M3x18 TP Screw	4	
		M2,6x6 TP Flat Head Screw	1	
		M3x6 TP Flat Head Screw	5	
		M3x10 TP Flat Head Screw	21	
		M3x15 TP Flat Head Screw	3	
		M2,6 Nut	10	
		M3 Nut	4	
		M3 Nylon Nut	1	
	M4 Nylon Nut	4		
	M2,3 Washer (Black)	8		
	M3 Washer	4		
	M4 Washer	2		
	M5 Washer	4		
	M3x3 Set Screw	1		
	M4x4 Set Screw	4		

LAYOUT DRAWING OF PLASTIC PARTS ON RUNNERS

(When cutting off parts from a runner...)

*Pay particular attention when detaching the position.

*Shaded parts are not used with this car.

Cut it off with a wire cutter.

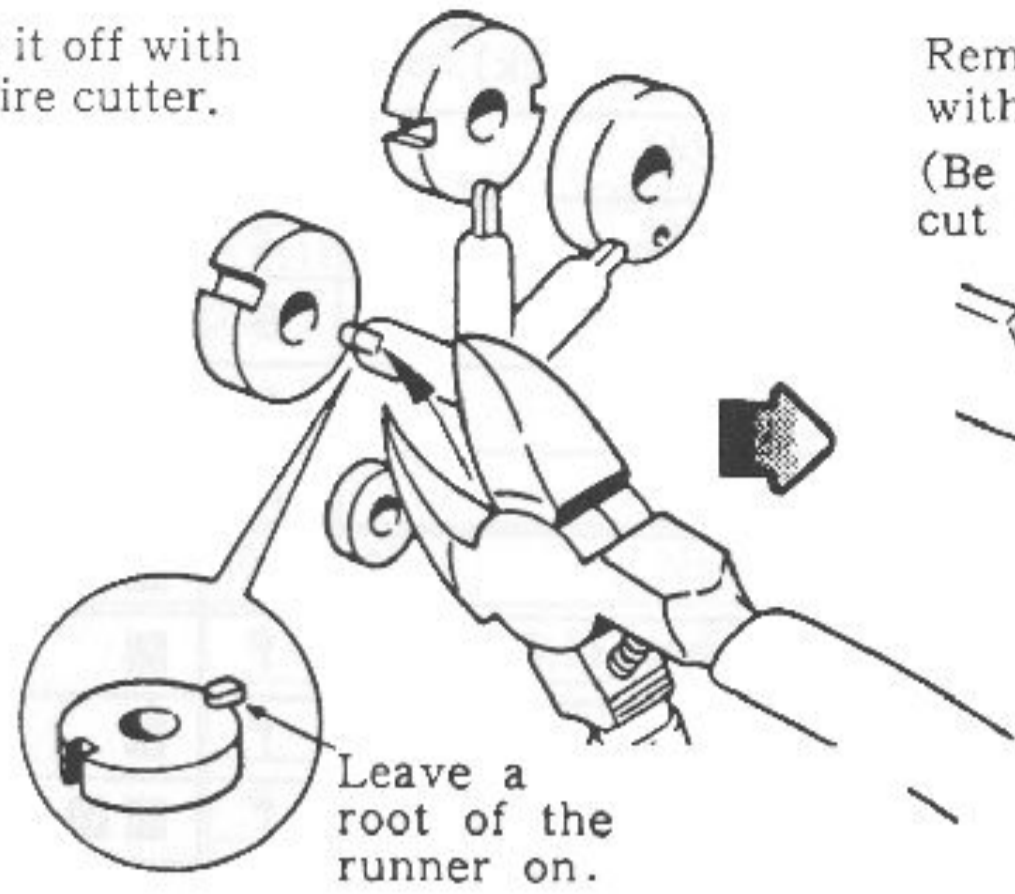

Remove the root with a hobby knife. (Be careful not to cut your finger.)

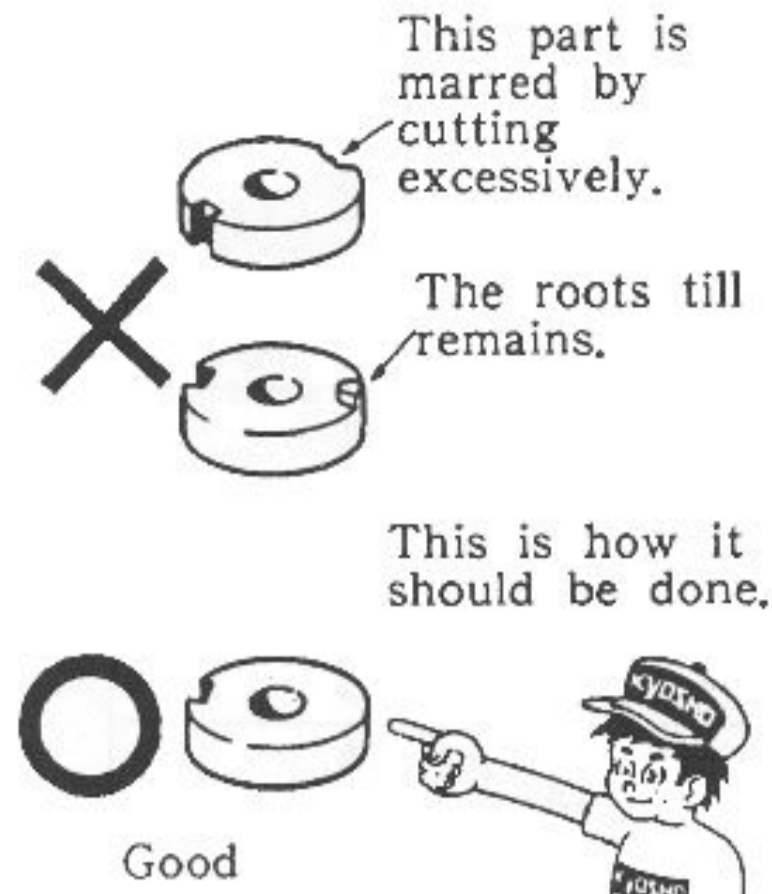
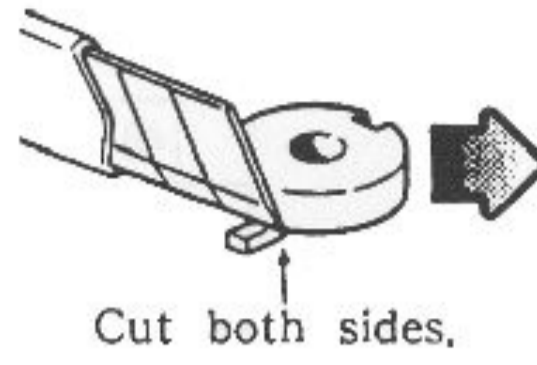

Shock Piston

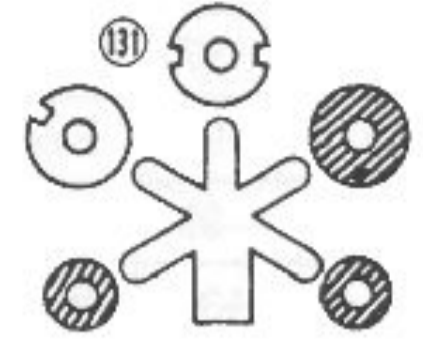

Wing Stay parts

Pully parts

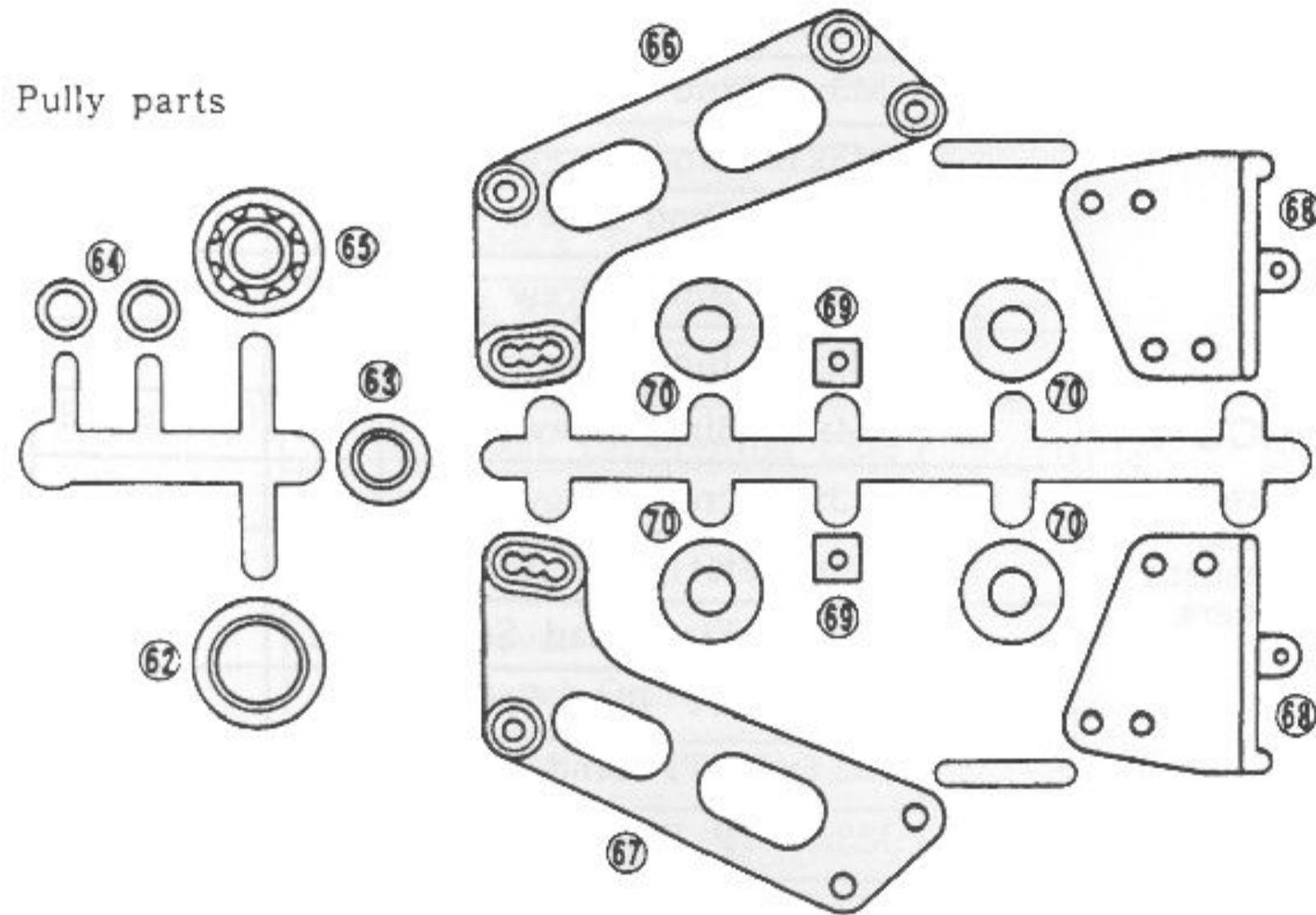

Battery Stopper Parts

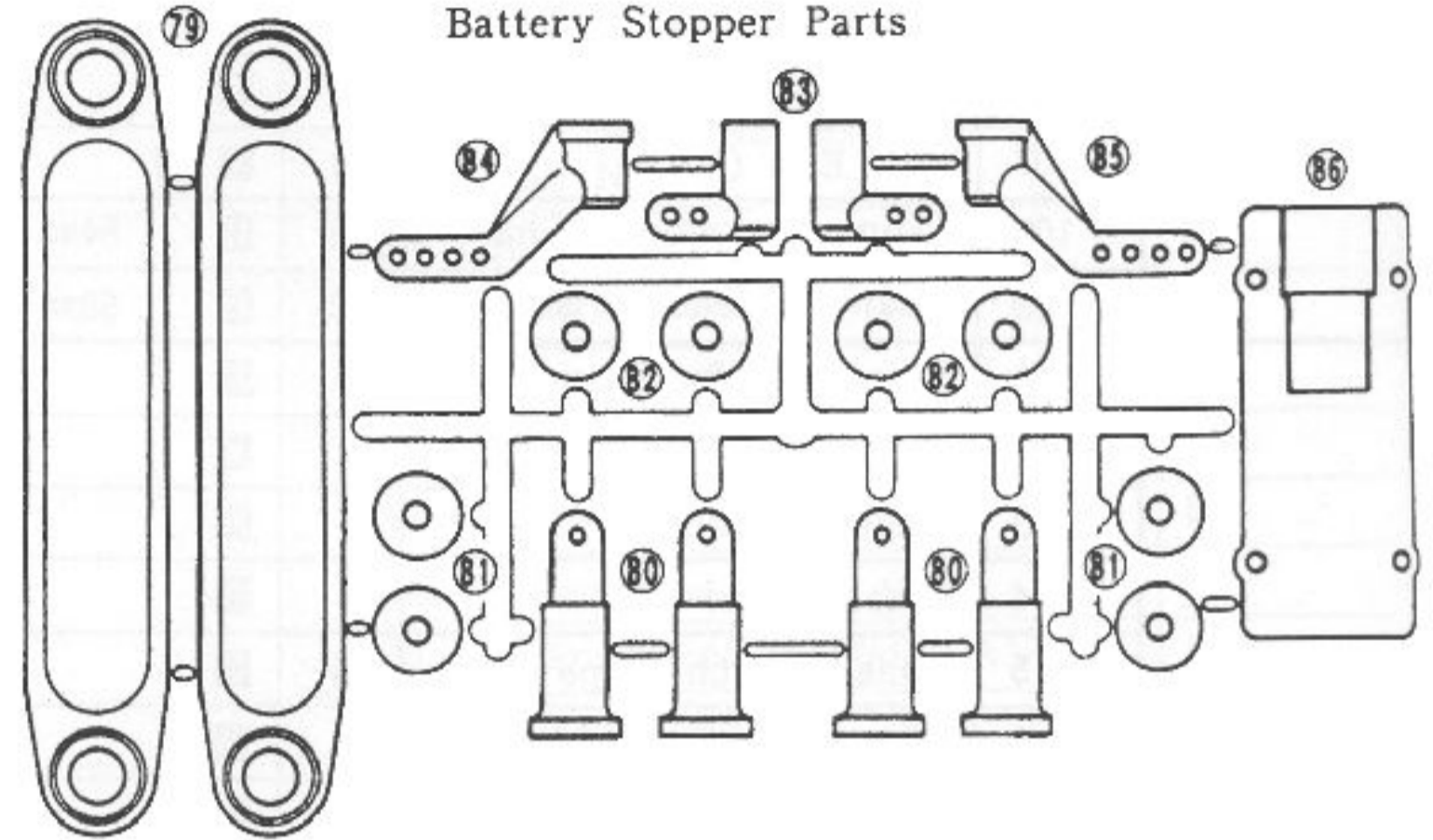

Arm Pivot Parts

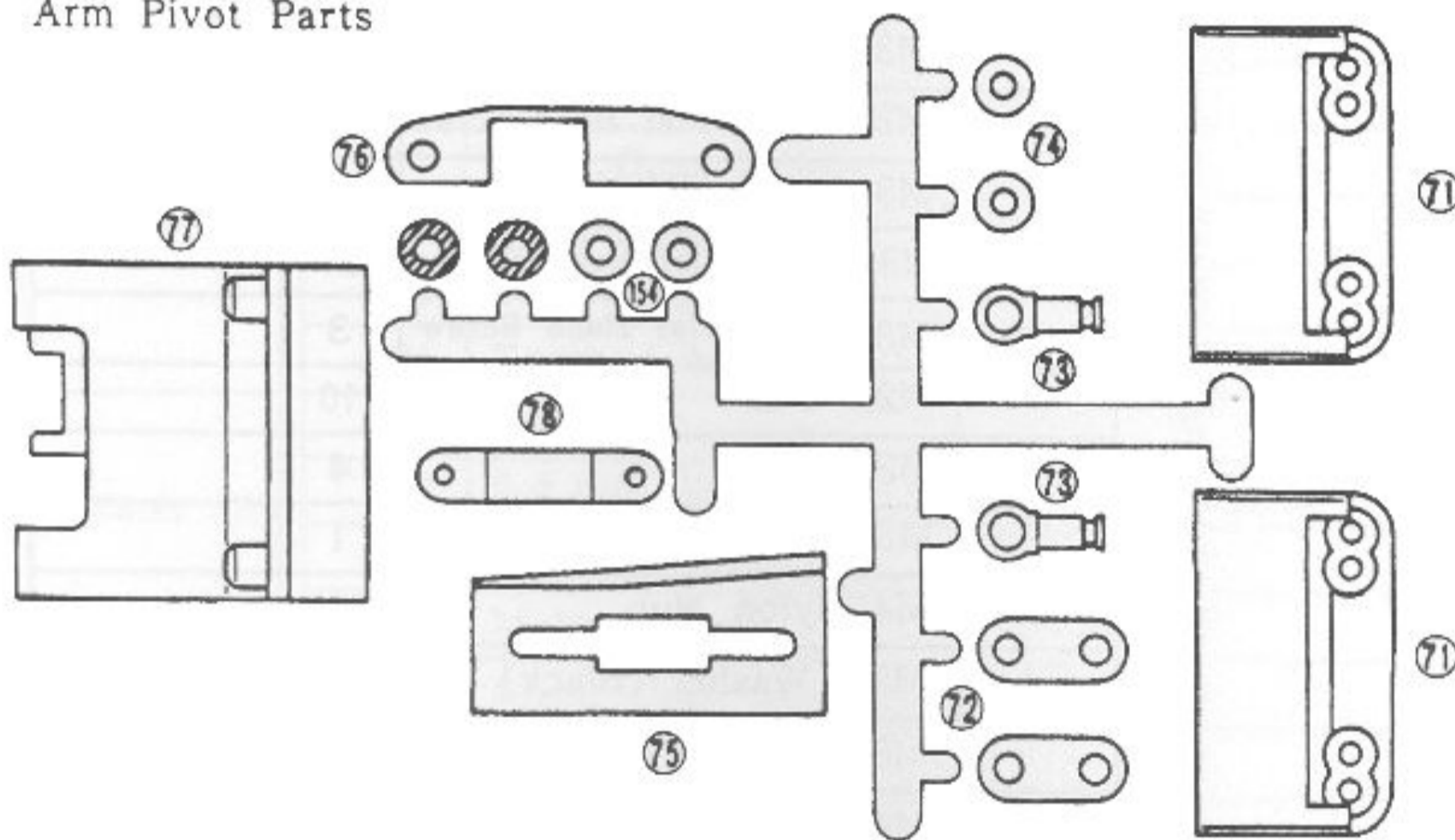

Servo Saver Parts

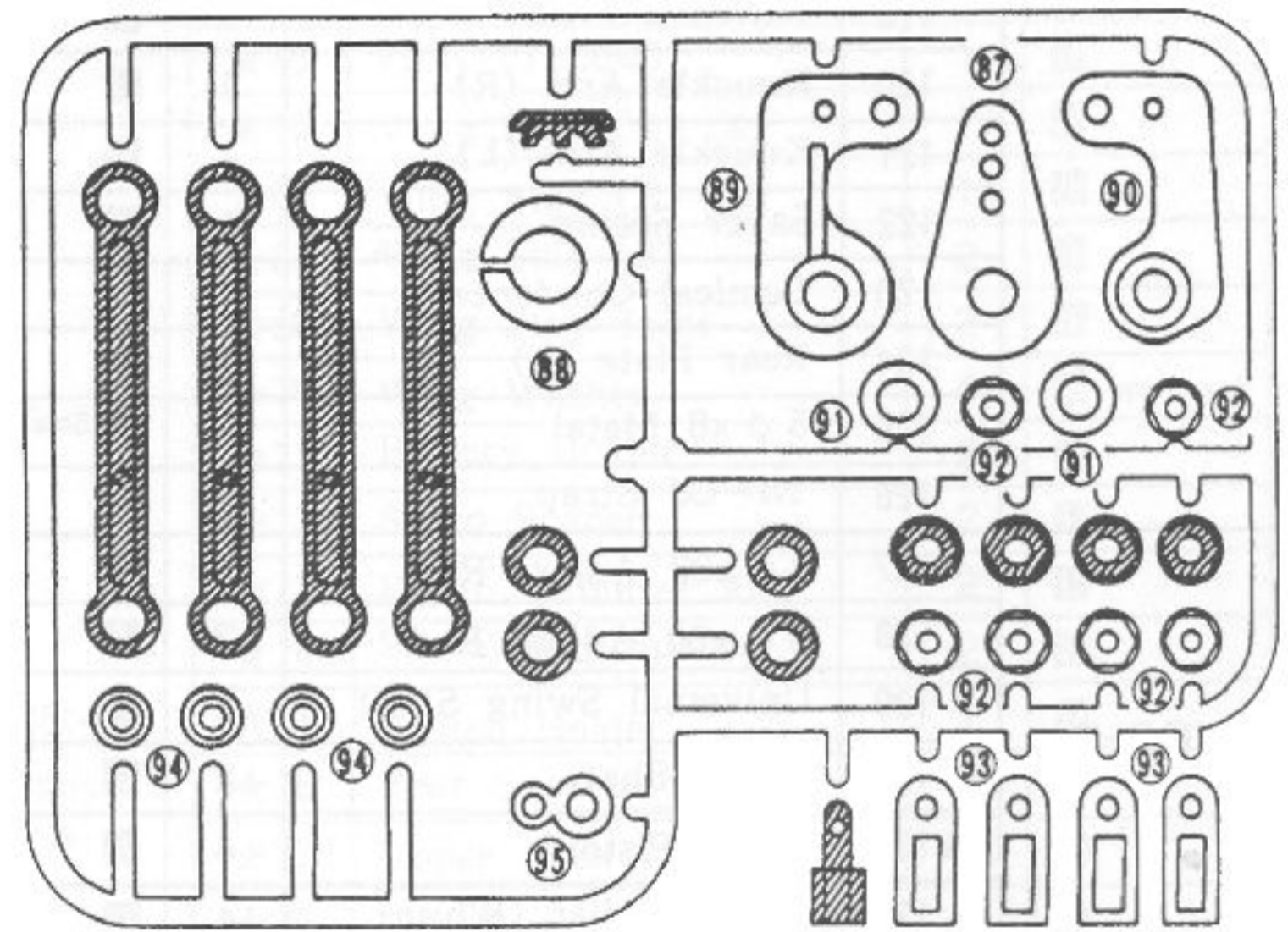

2

(1) Push in till the end.

*If plane bearing is hard to push in then use a shaft.

(2) After installed plane bearing.

*Check if shaft will turn smoothly, if not, bearing in not strait.

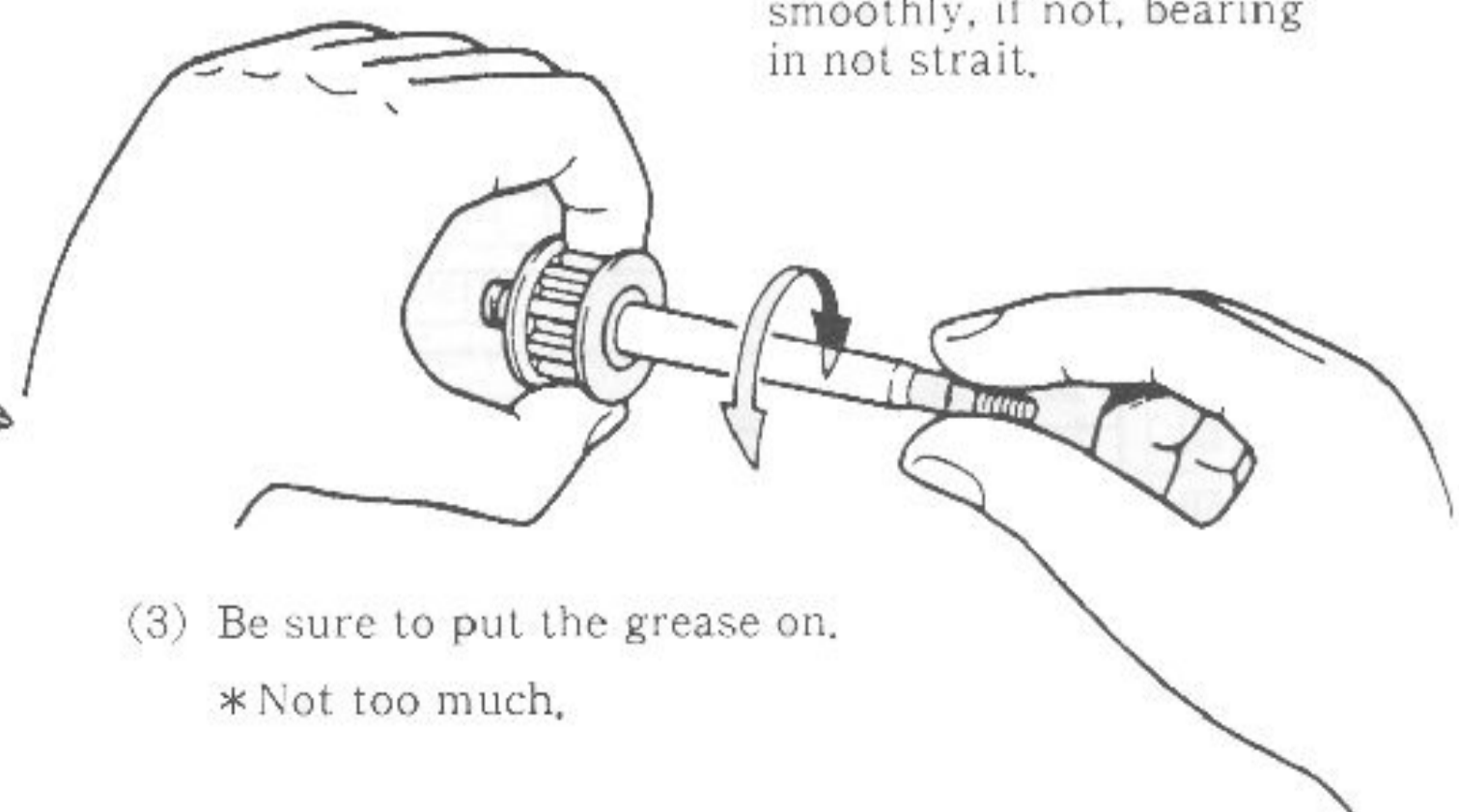
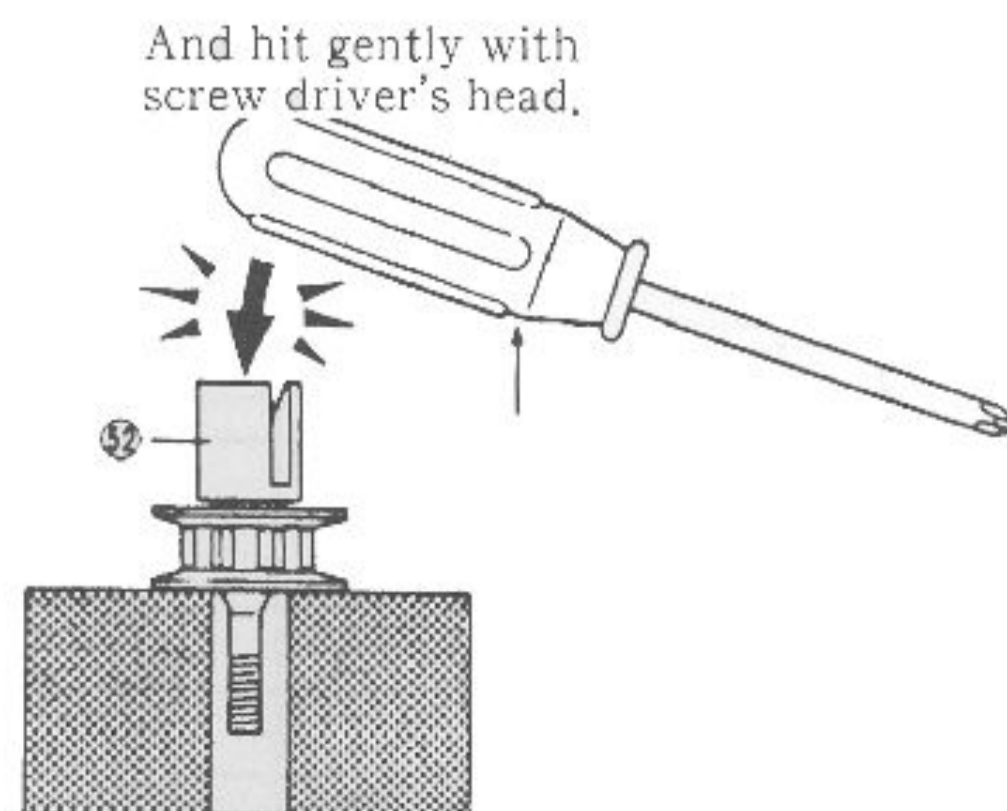
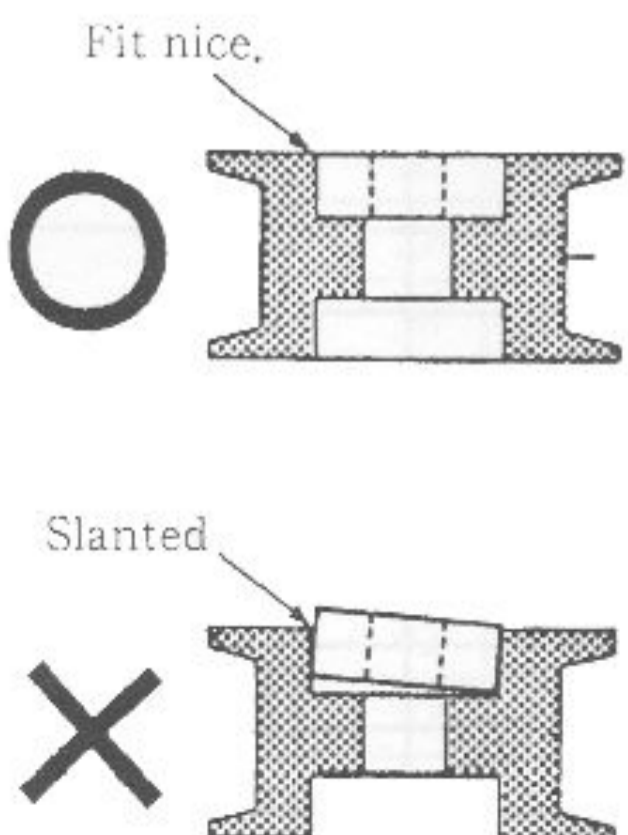

1 ASSEMBLY OF RODS

*Screw in the ball ends, identifying the length with the life size drawing.
Two rods of each size are required.

Assemble with caution so that the rod faces the right direction and the 5.8 φ ball is the correct color.

Side with the step has reverse thread. Screw in the ball end anti-clockwise.

(1) Screw in the ball end (L)

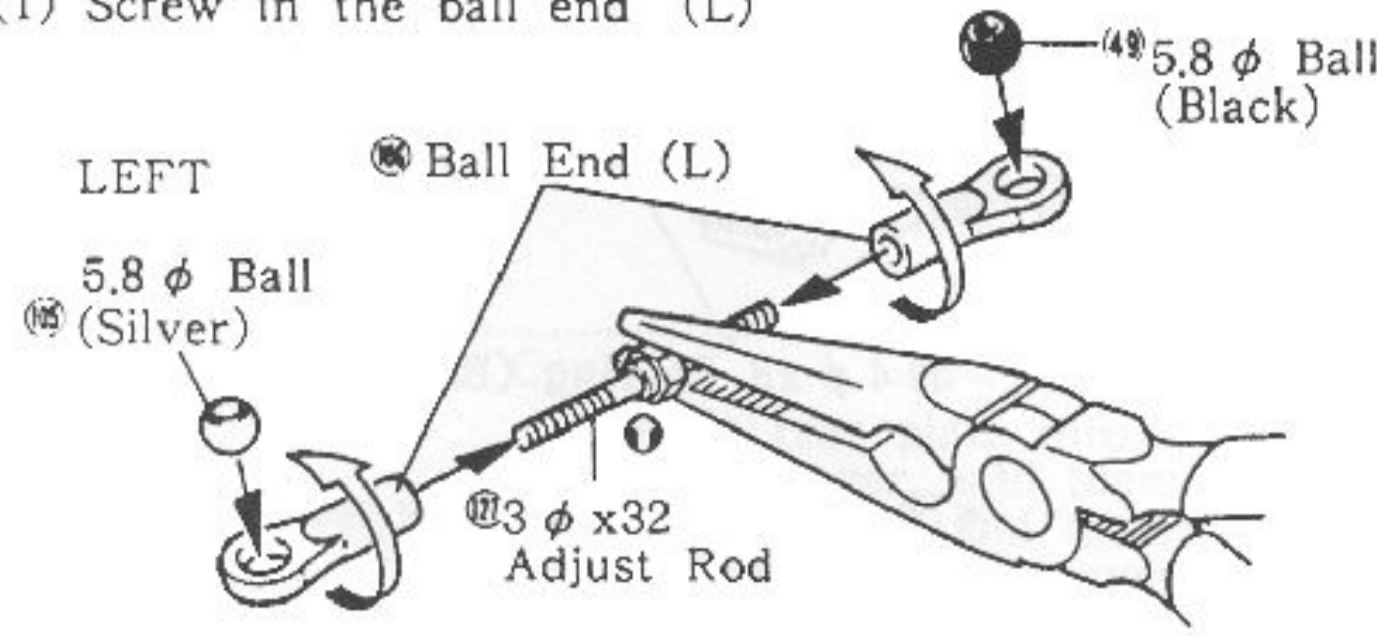

RIGHT

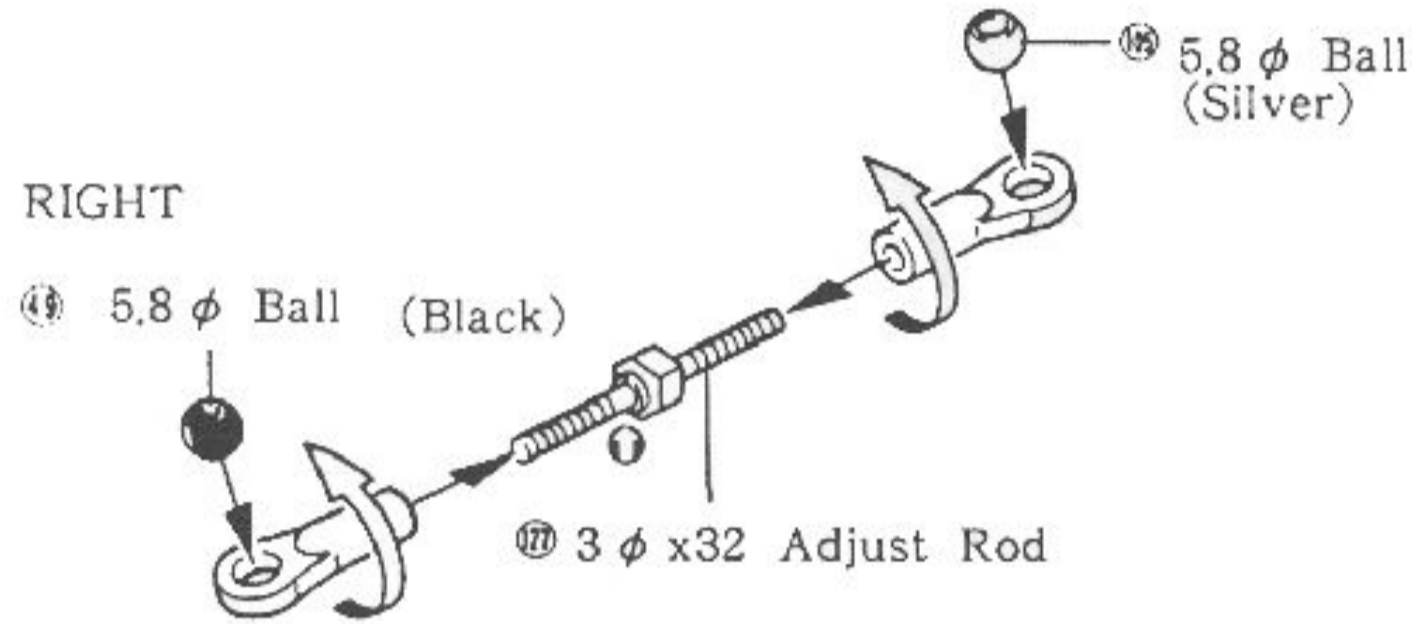

(Actual Size)
Front Upper Rod

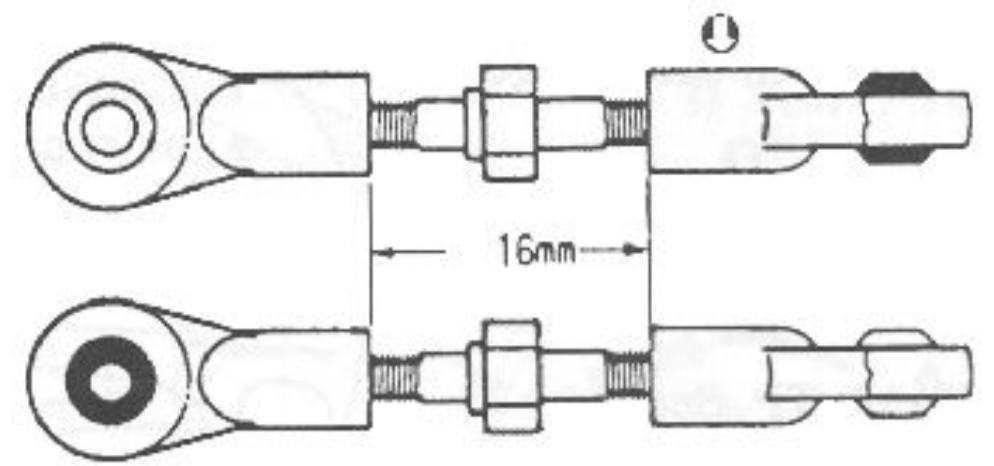

Rear Upper Rod

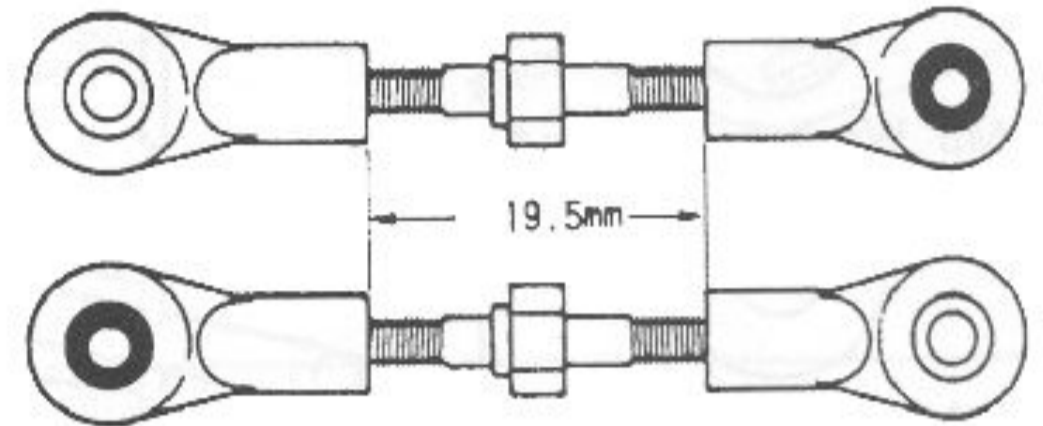

- [MCS-4] 5.8 φ Balls (Black) ... 6
- [MCS-7] 5.8 φ Ball (Silver) ... 6
- Ball End (L) ... 12
- Ball End (S) ... 1
- [MCS-9] 3 φ x32 Adjust Rods ... 4
- 3 φ x50 Adjust Rods ... 2

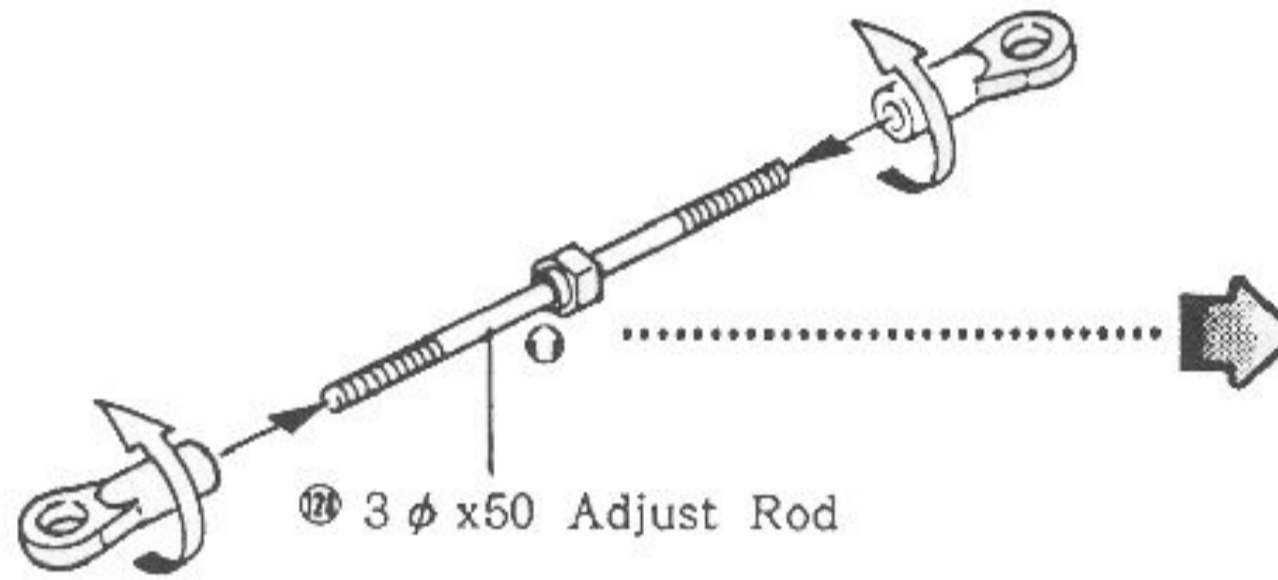

Tie Rod

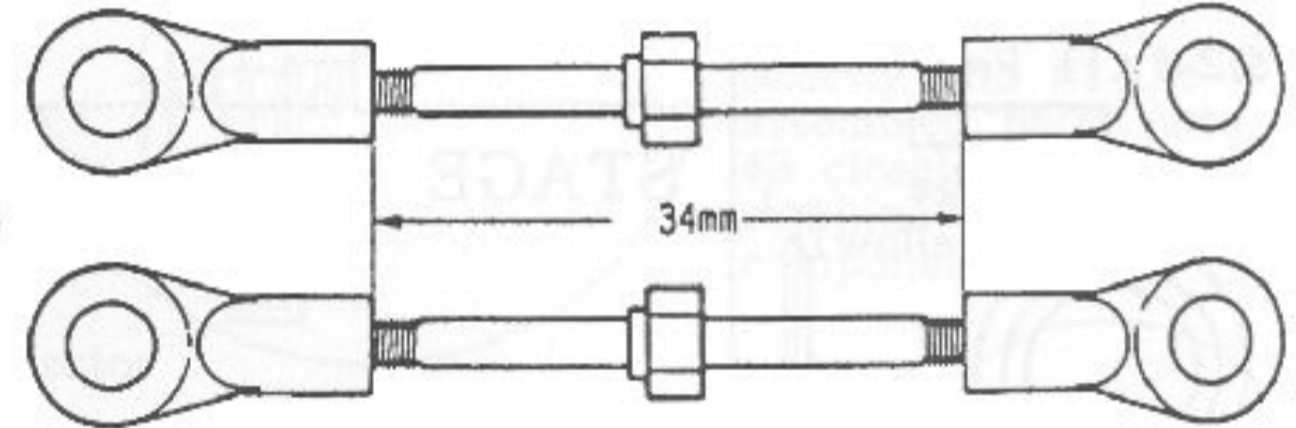

(2) Installing location and direction of each rod.

(The side with the step is installed on the left side.)

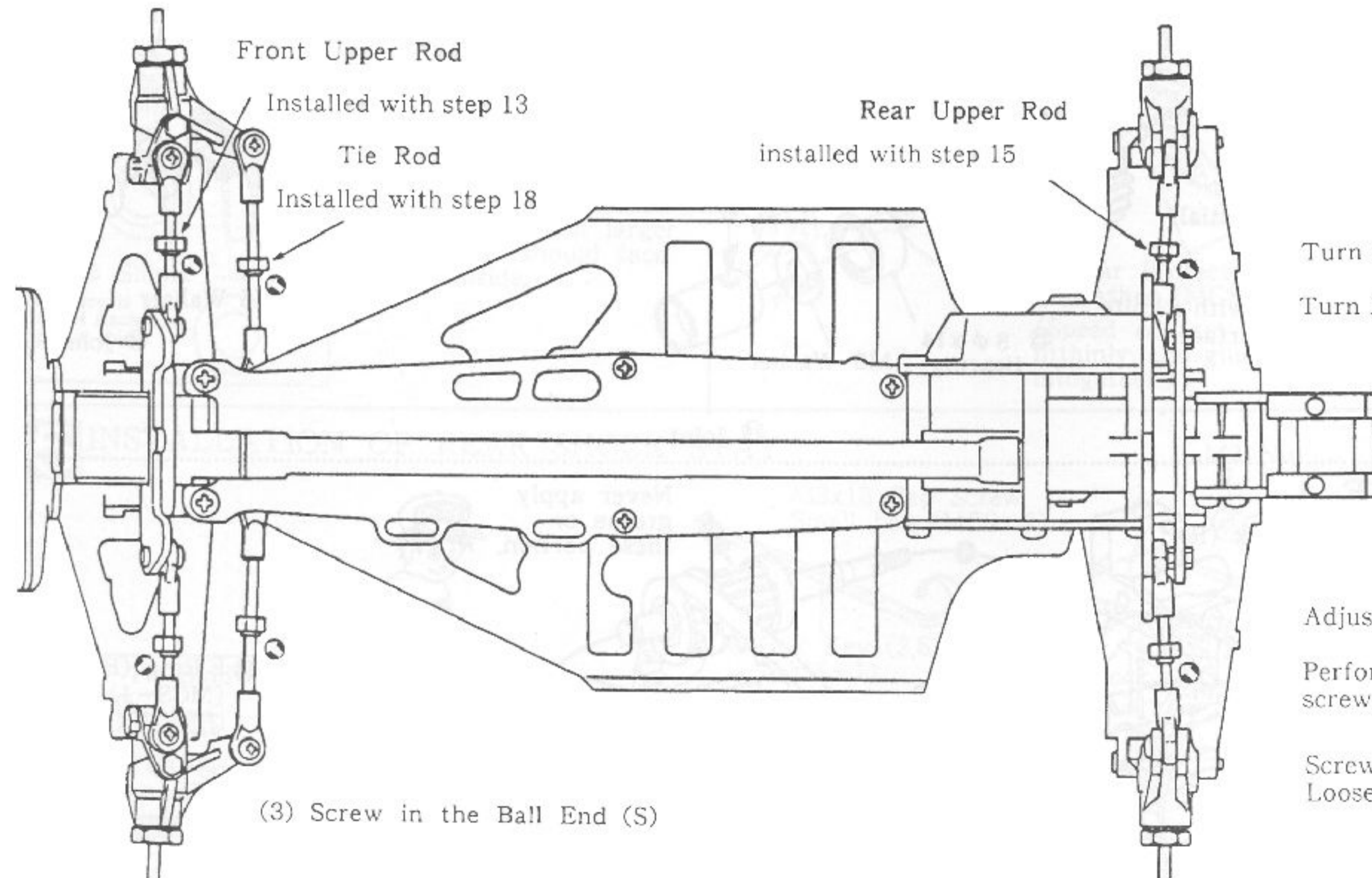

(3) Screw in the Ball End (S)

Adjustment of Length

Use 5.5 mm wrench.

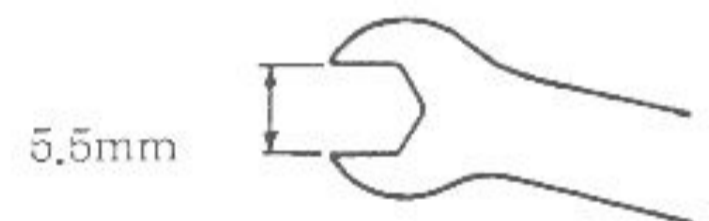

Turn Forward...Become Long

Turn Backward...Become Short

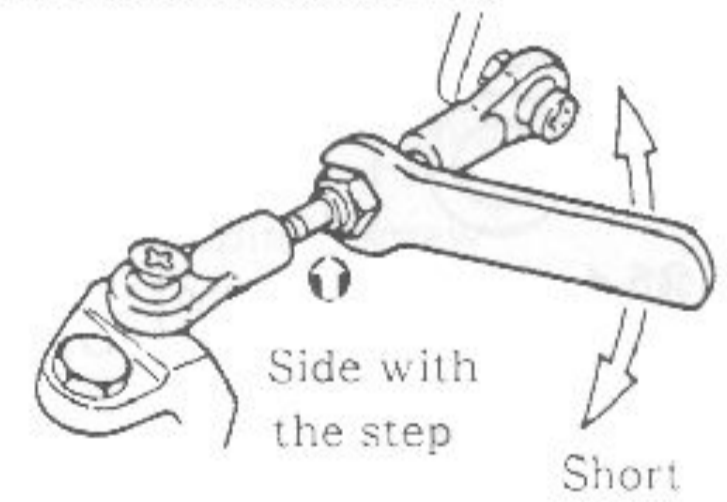

Adjustment of Length

Perform with the amount of ball end screw in or out.

Screw In...Become Short
Loosened ...Becomes Long

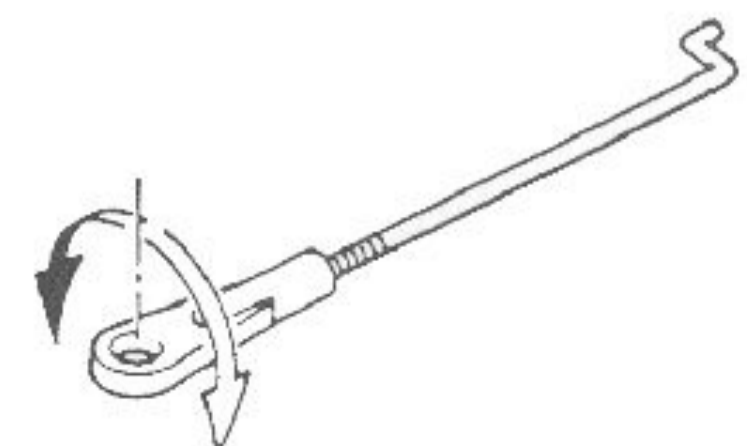
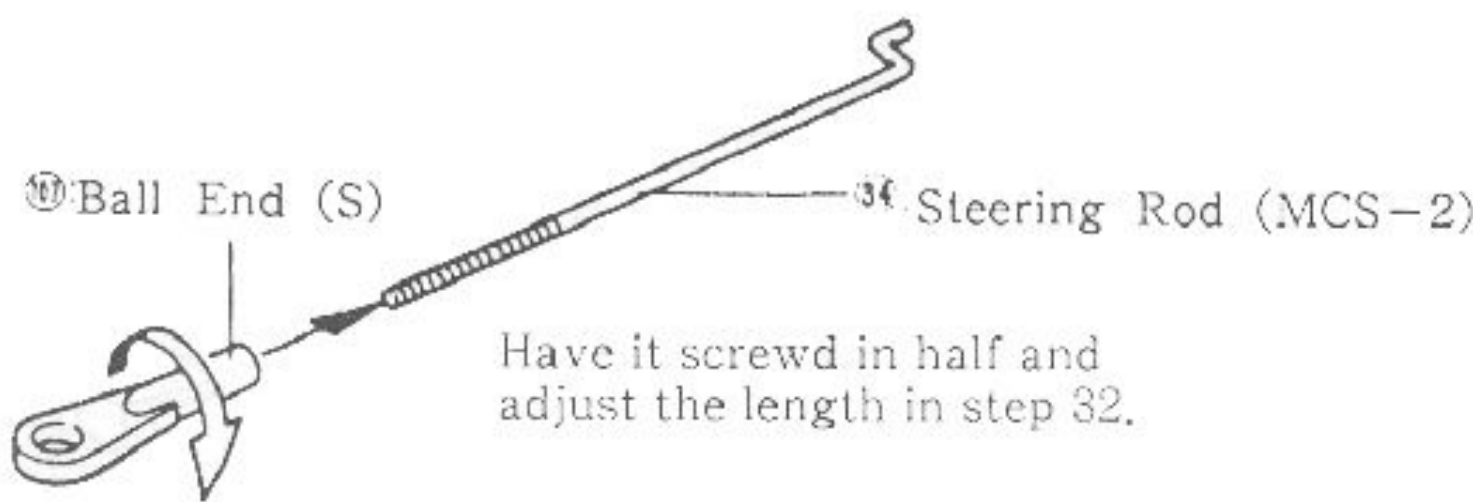

2 ASSEMBLY OF REAR GEAR BOX

At each assembly stage, a drawing shows screws and other fasteners used in the actual size. Identify those required in each stage.

- ① M4x4 Set Screws...4
- M3x18 TP Screws...2
- M4 Washers2
- M5 Washers4
- ② 8 φ x14 Bearings...4
- ③ 2 φ x11 Pin1
- ④ Pully Flange (Yellow) ...1
- ⑤ 5 φ Collar (S) (Yellow)1
- ⑥ Pully (Yellow).....1
- ⑦ 4 φ x8 Bearings...2
- ⑧ 5 φ x8 Metals2
- ⑨ 5 φ x10 Bearings...2
- ⑩ E Rings(E4)2

STAGE 1

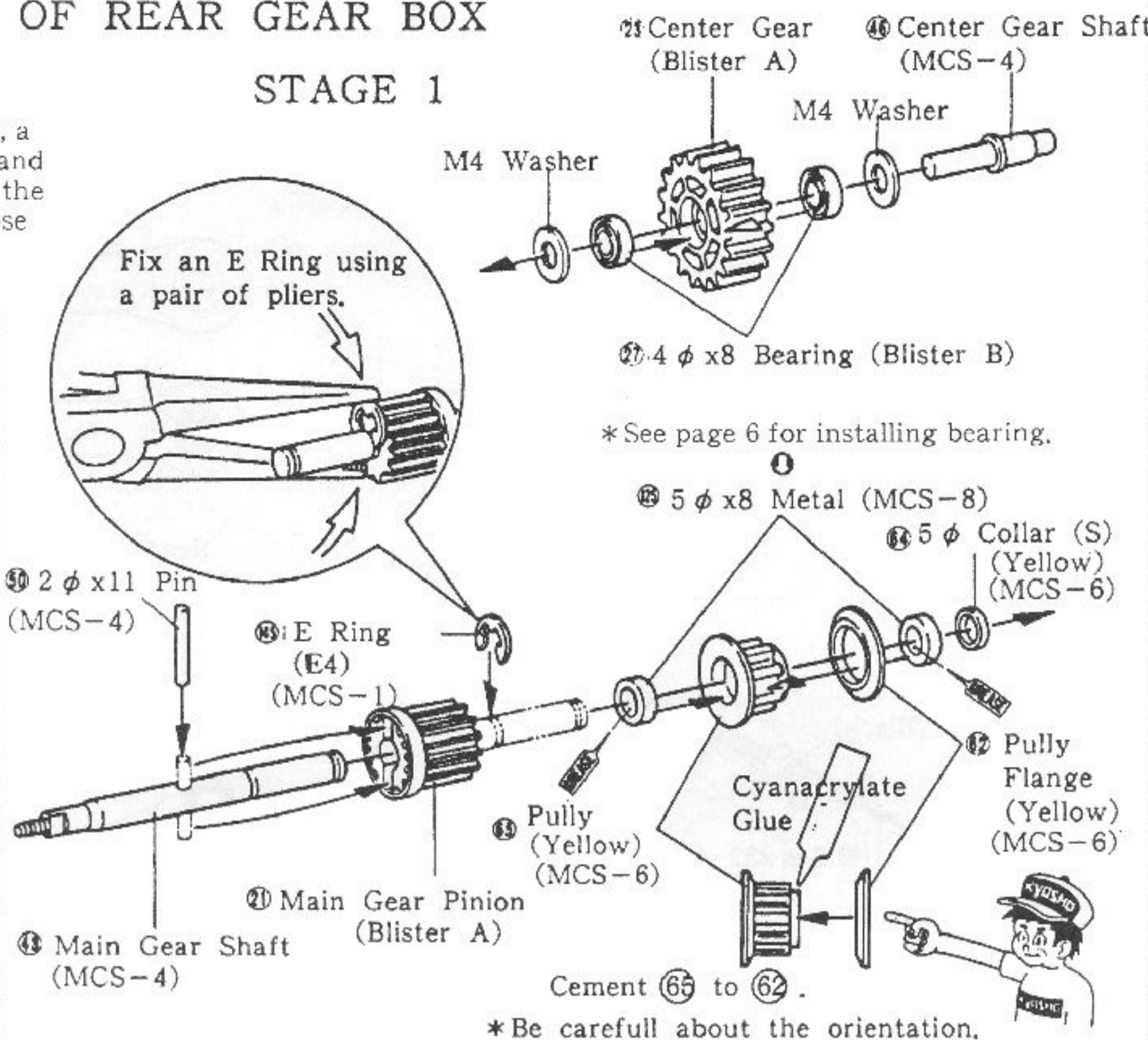

STAGE 2

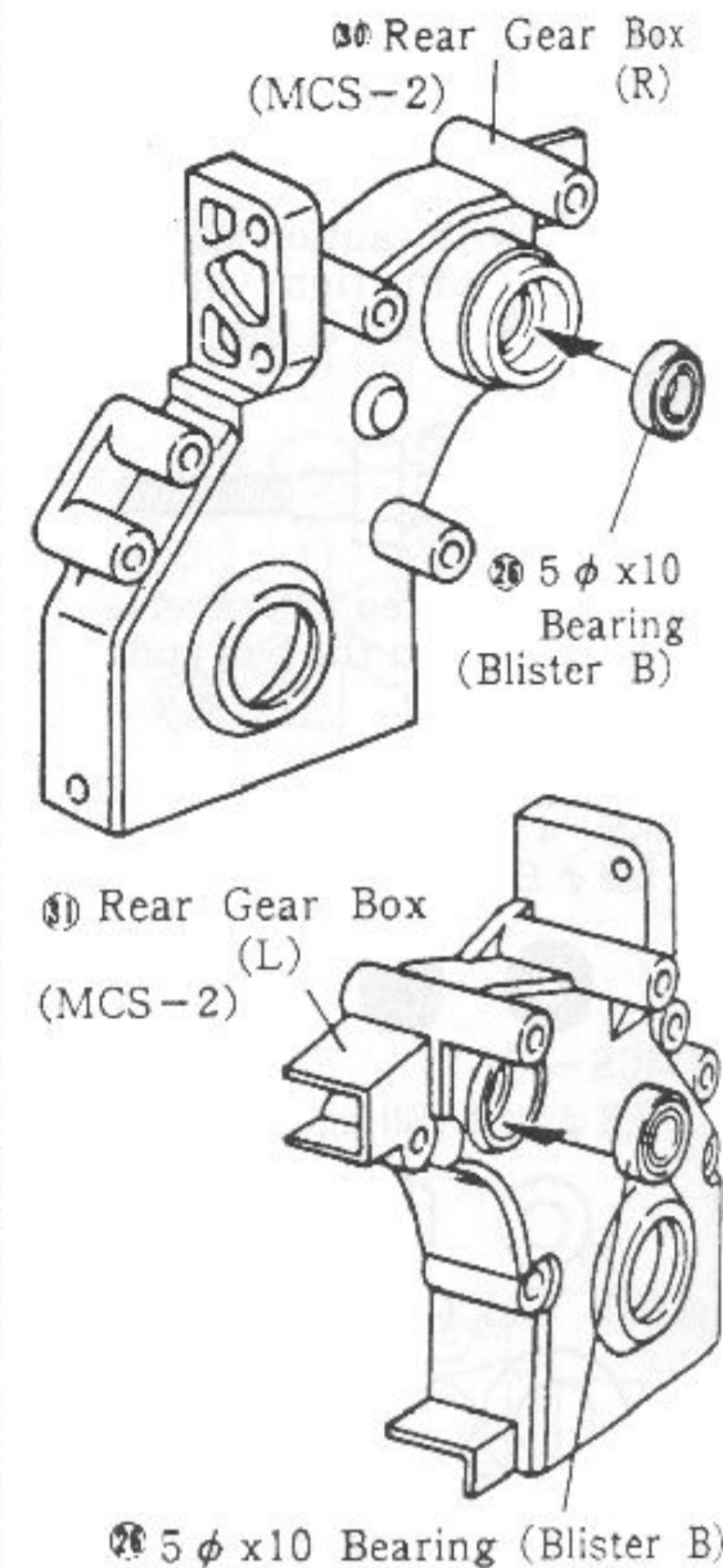

STAGE 3

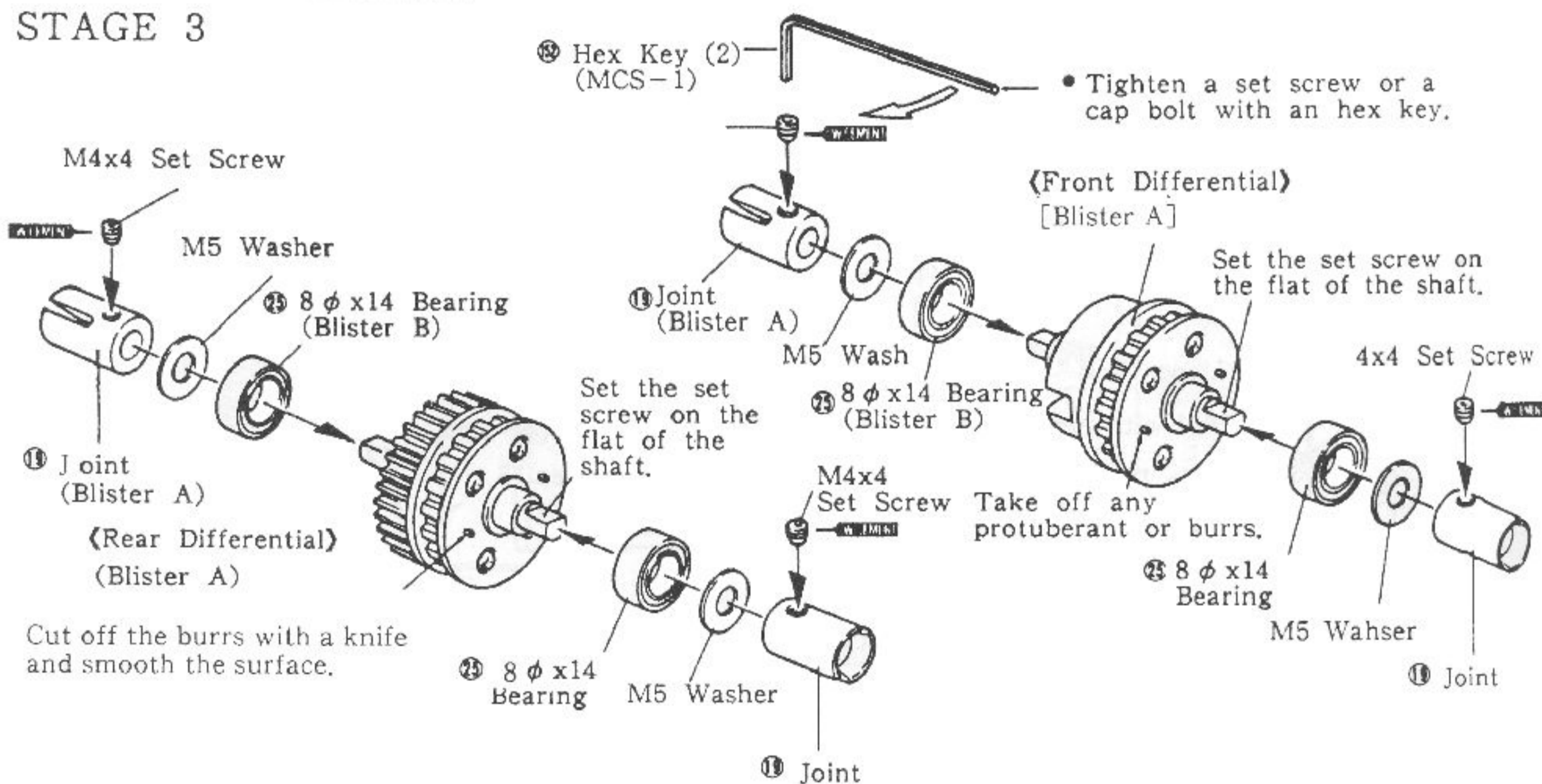

STAGE 4

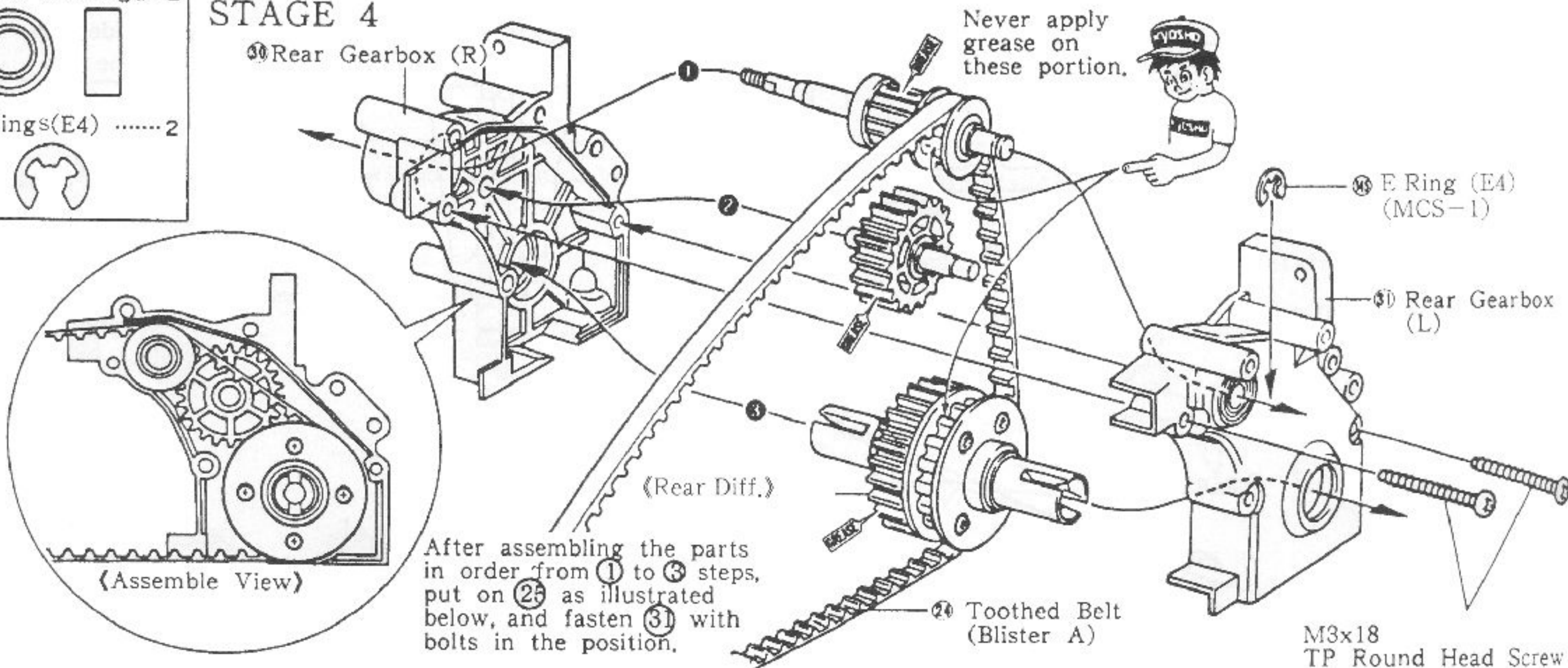

3 INSTASLLATION OF REAR PLATE

M3x35 Bind Screw 1



M3x45 Bind Screws 2



④ Rear Upper Plate (R) (MCS-5)

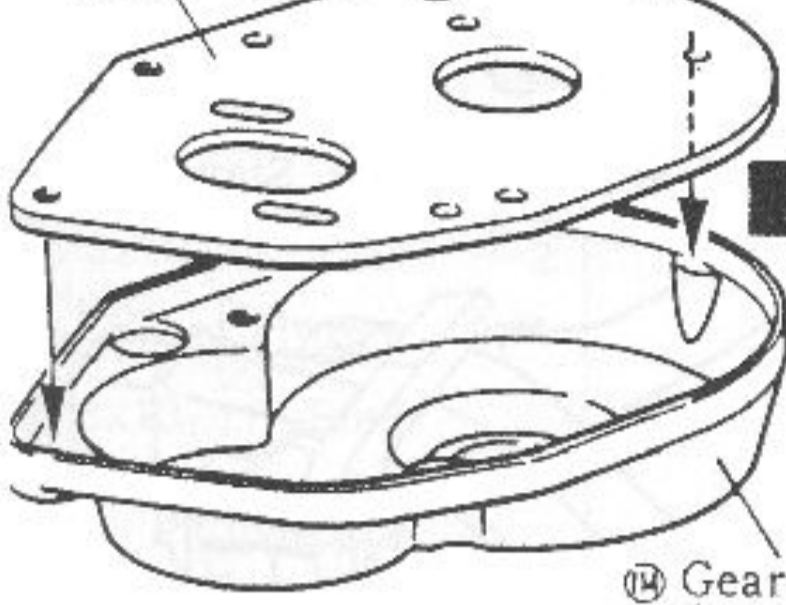

⑫ Gear Cover (MCS-8)

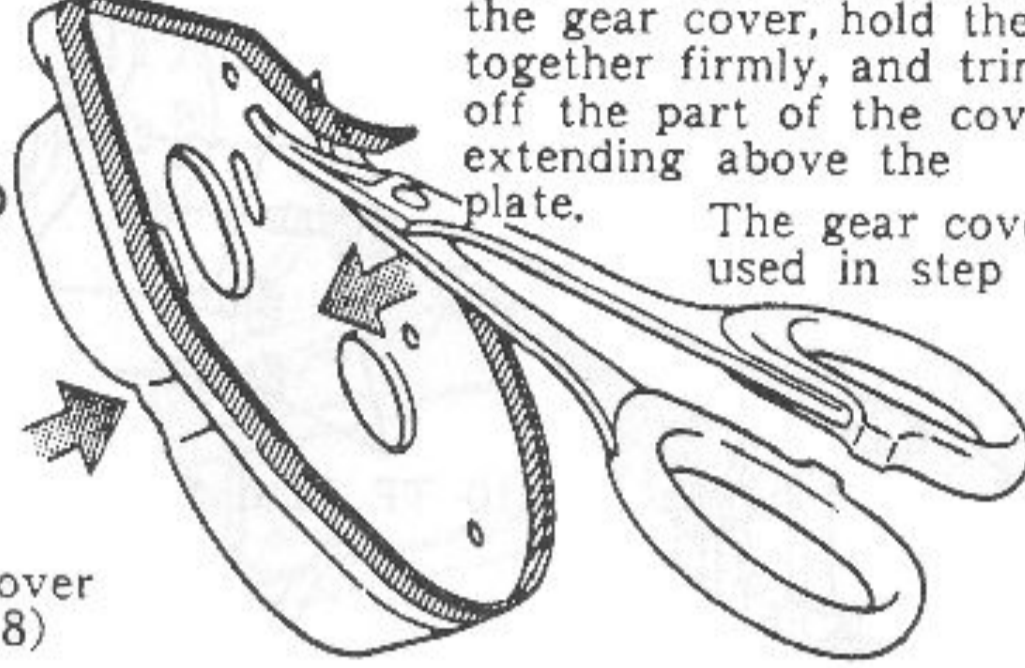

STAGE 1 (Cut Rear Cover)

Put the rear plate into the gear cover, hold them together firmly, and trim off the part of the cover extending above the plate. The gear cover is used in step 27.

⑮ Rear Plat (L) (MCS-8)

STAGE 2

M3x45 Bind Screw

M3x35 Bind Screw

⑭ Rear Plate (R)

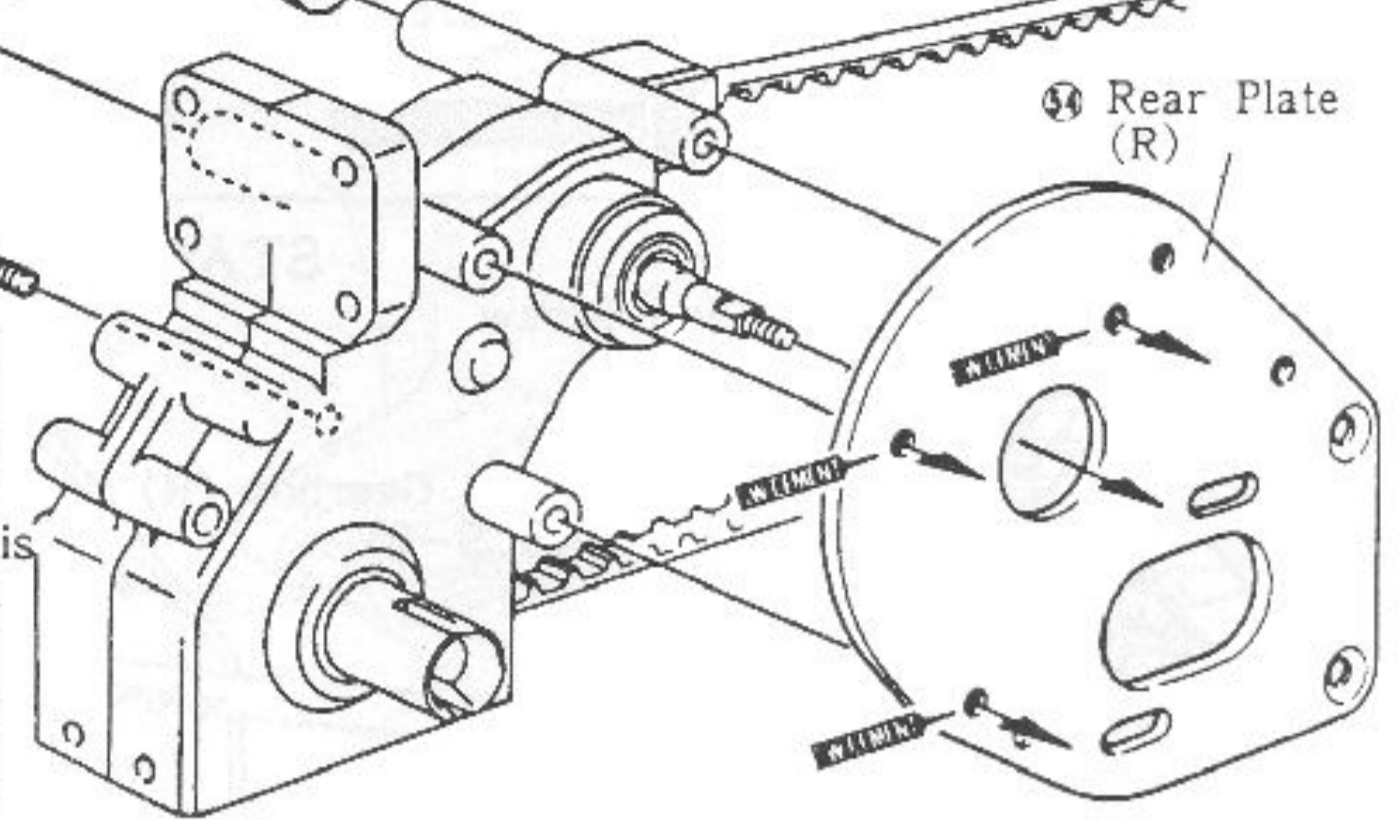

4 INSTALLATION OF SPUR GEAR

When assembling as shown in the drawing at right and if you find too much end play in the shaft, remove the R-ring on this side once and put another one 147 or two.



⑮ 5 φ Shim (MCS-1)

M3 Nylon Nut 1

5 φ Collar (L) (Yellow) 1

⑮ 5 φ Shims 2

If there is too much slachness put a shim.

⑮ 5 φ Shims 2

If there is too much slachness put a shim.

⑮ 5 φ Shims 2

If there is too much slachness put a shim.

⑮ 5 φ Shims 2

If there is too much slachness put a shim.

⑮ 5 φ Shims 2

If there is too much slachness put a shim.

⑮ 5 φ Shims 2

If there is too much slachness put a shim.

⑮ 5 φ Shims 2

If there is too much slachness put a shim.

⑮ 5 φ Shims 2

If there is too much slachness put a shim.

⑮ 5 φ Shims 2

If there is too much slachness put a shim.

⑮ 5 φ Shims 2

If there is too much slachness put a shim.

⑮ 5 φ Shims 2

If there is too much slachness put a shim.

⑮ 5 φ Shims 2

If there is too much slachness put a shim.

⑮ 5 φ Shims 2

If there is too much slachness put a shim.

⑮ 5 φ Shims 2

If there is too much slachness put a shim.

⑮ 5 φ Shims 2

If there is too much slachness put a shim.

⑮ 5 φ Shims 2

If there is too much slachness put a shim.

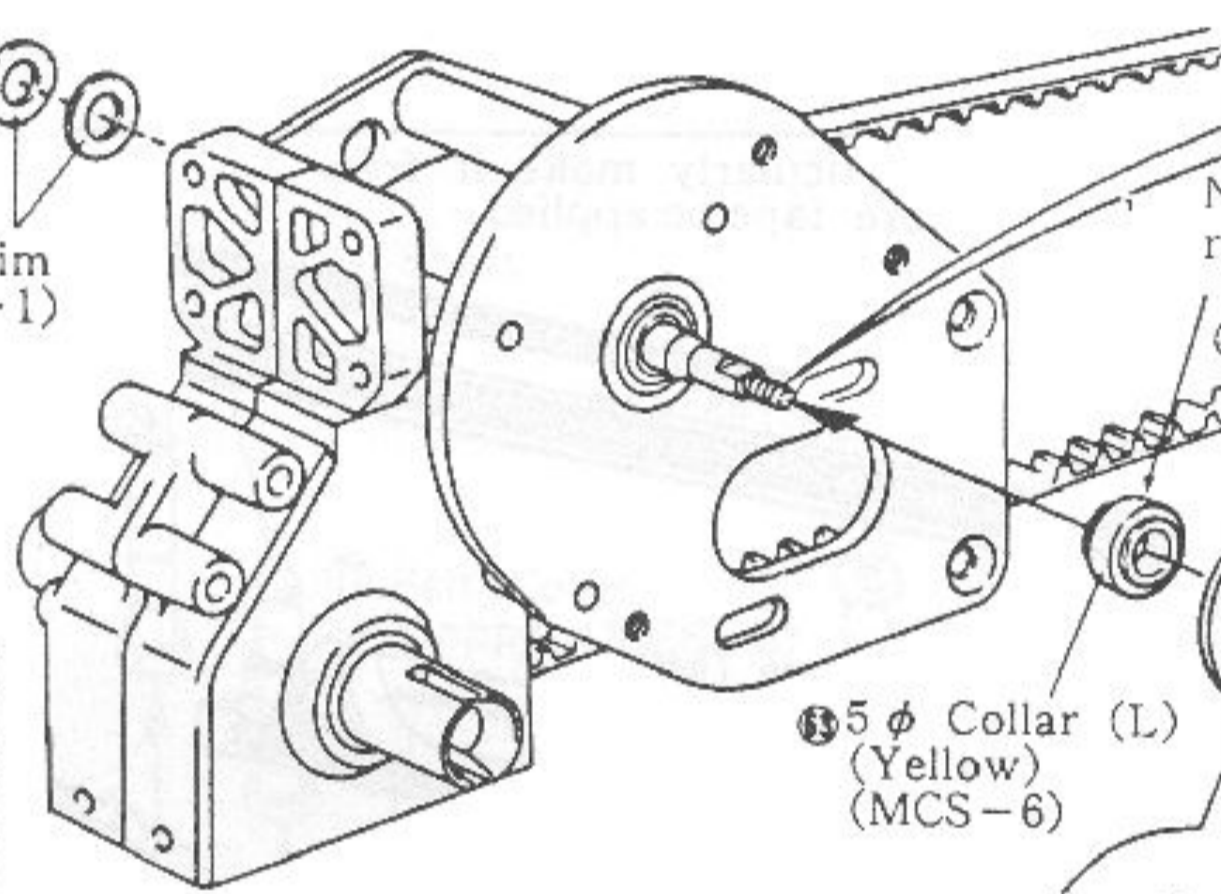

No orientation required.

⑭ Gear Protector Plate (B) (MCS-4)

⑮ 5 φ Collar (L) (Yellow) (MCS-6)

⑰ Main Gear (Blister A)

⑱ Gear Protector Plate (A) (MCS-5)

⑲ Gear Protector Washer (MCS-4) ⑳ Wave Washer (MCS-1) ㉑ Gear Protector collar (MCS-4) M3 Nylon Nut

Tighten the M3 nylon nut until it become flush with the tip of the shaft.

True up the 148 exactly and fit the assembled parts onto 45 closely, then combine the whole components.

Be careful about the orientation larger hole should face inside.



5 INSTALLATION OF REAR SHOCK STAY

M3x10 TP Bind s 4 Screw

M3x18 Cap Screws 2

M3 Nuts 2

M3 Nuts 2

M3 Nuts 2

M3 Nuts 2

M3 Nuts 2

M3 Nuts 2

M3 Nuts 2

M3 Nuts 2

M3 Nuts 2

M3 Nuts 2

M3 Nuts 2

M3 Nuts 2

M3 Nuts 2

M3 Nuts 2

M3 Nut M3x10 TP Bind Screw M3x18 Cap Screw Small bag (MCS-9)

⑲ Hex Key (2.5) (MCS-1) ⑳ Rear Shock Stay (MCS-5) ㉑ 3 Nut

⑳ Rear Upper Plate (MCS-5)

M3x10 TP Bind Screw

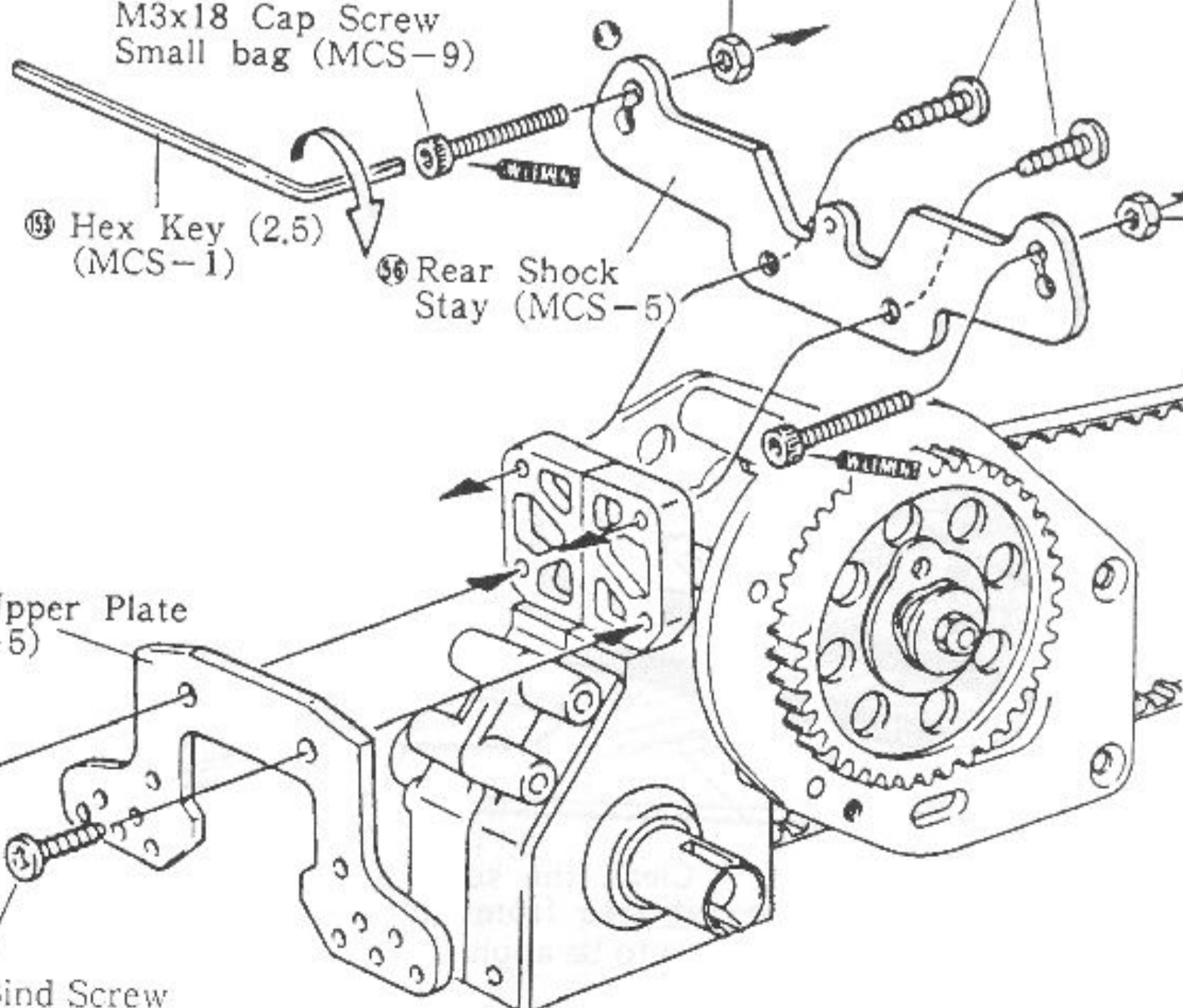

6 ASSEMBLY OF FRONT GEARBOX

- | | | |
|---------------------------|----------------------------------|--------------|
| M3x6 TP Bind Screws ...2 | M3x18 TP Round Head Screws2 | M3 Nuts ...2 |
| M3x10 TP Bind Screws ...4 | M3x18 Cap Screws2 | |

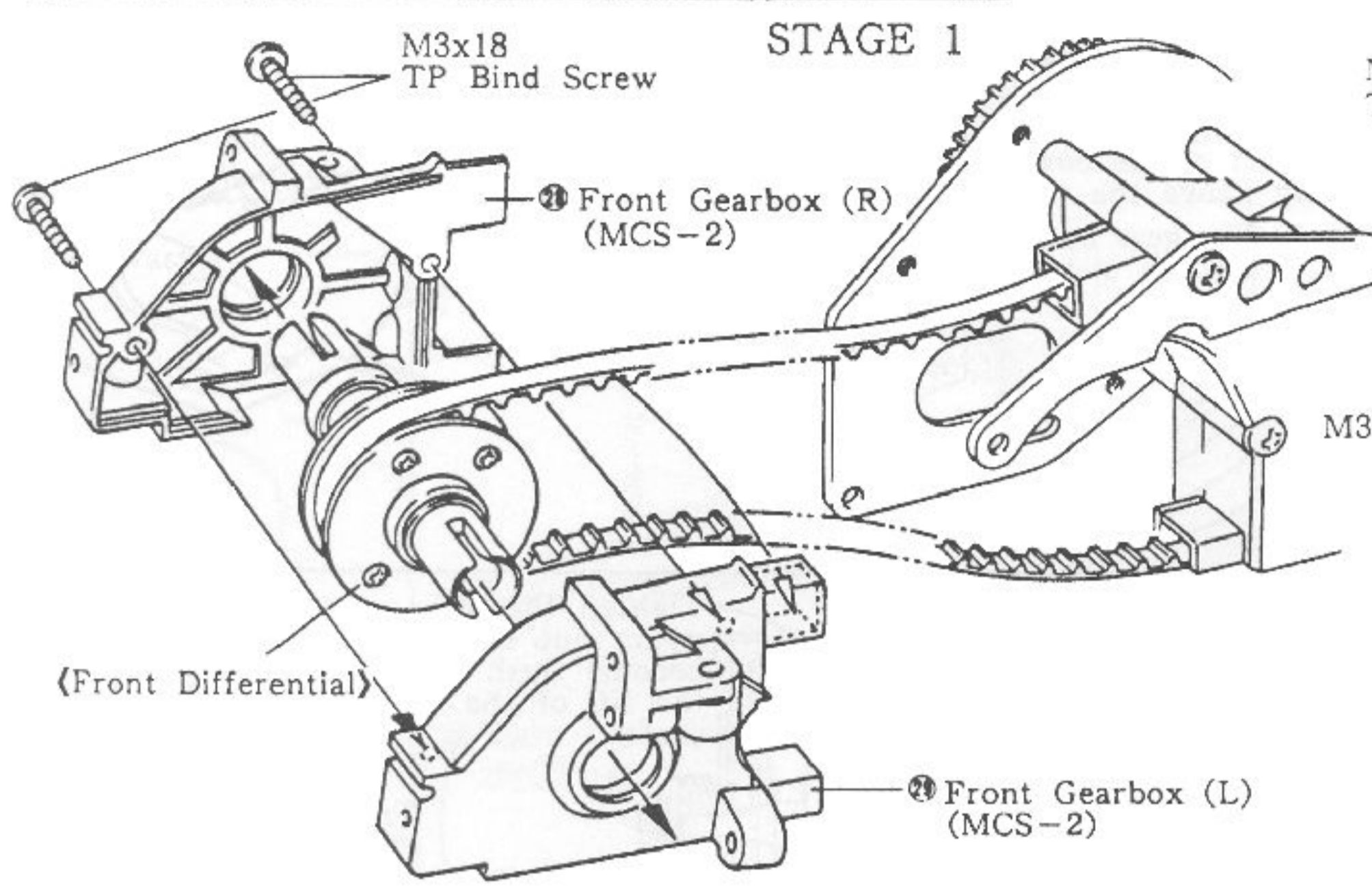

STAGE 2

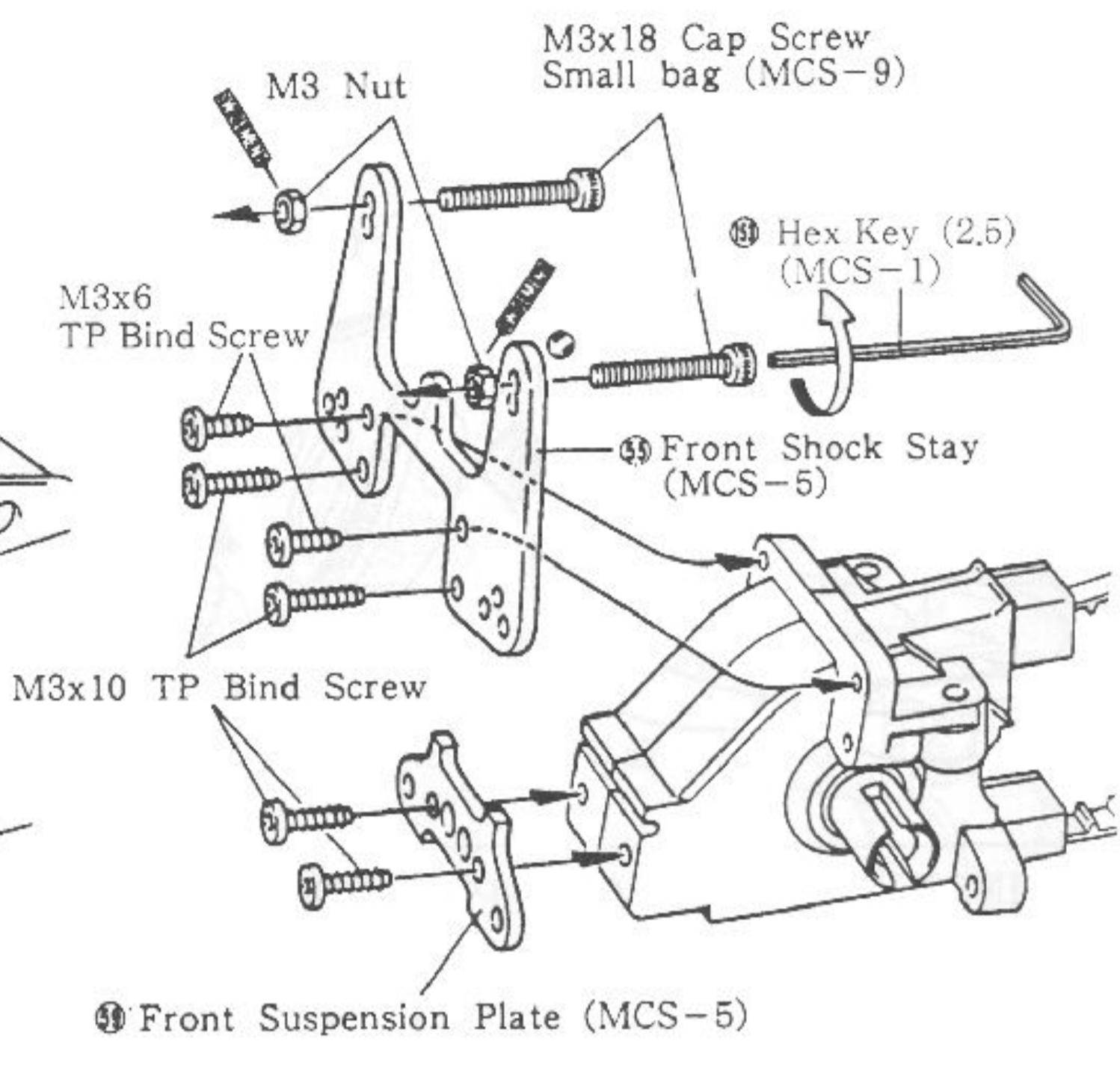

7 INSTALLATION OF GEARBOX

Clean the surface, particularly make it free from oily stain, where tape be applied.

STAGE 1

- | |
|----------------------------------|
| M3x10 TP Flat Head Screws5 |
| M3x15 TP Flat Head Screw1 |

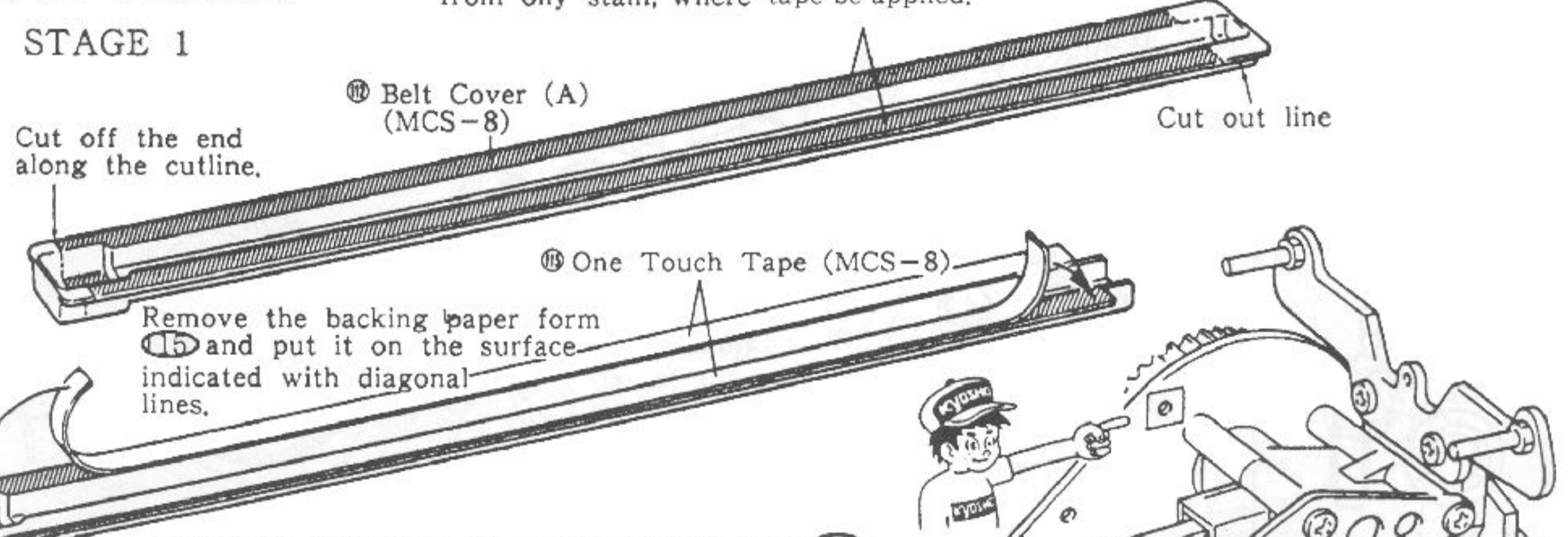

STAGE 2

STAGE 3

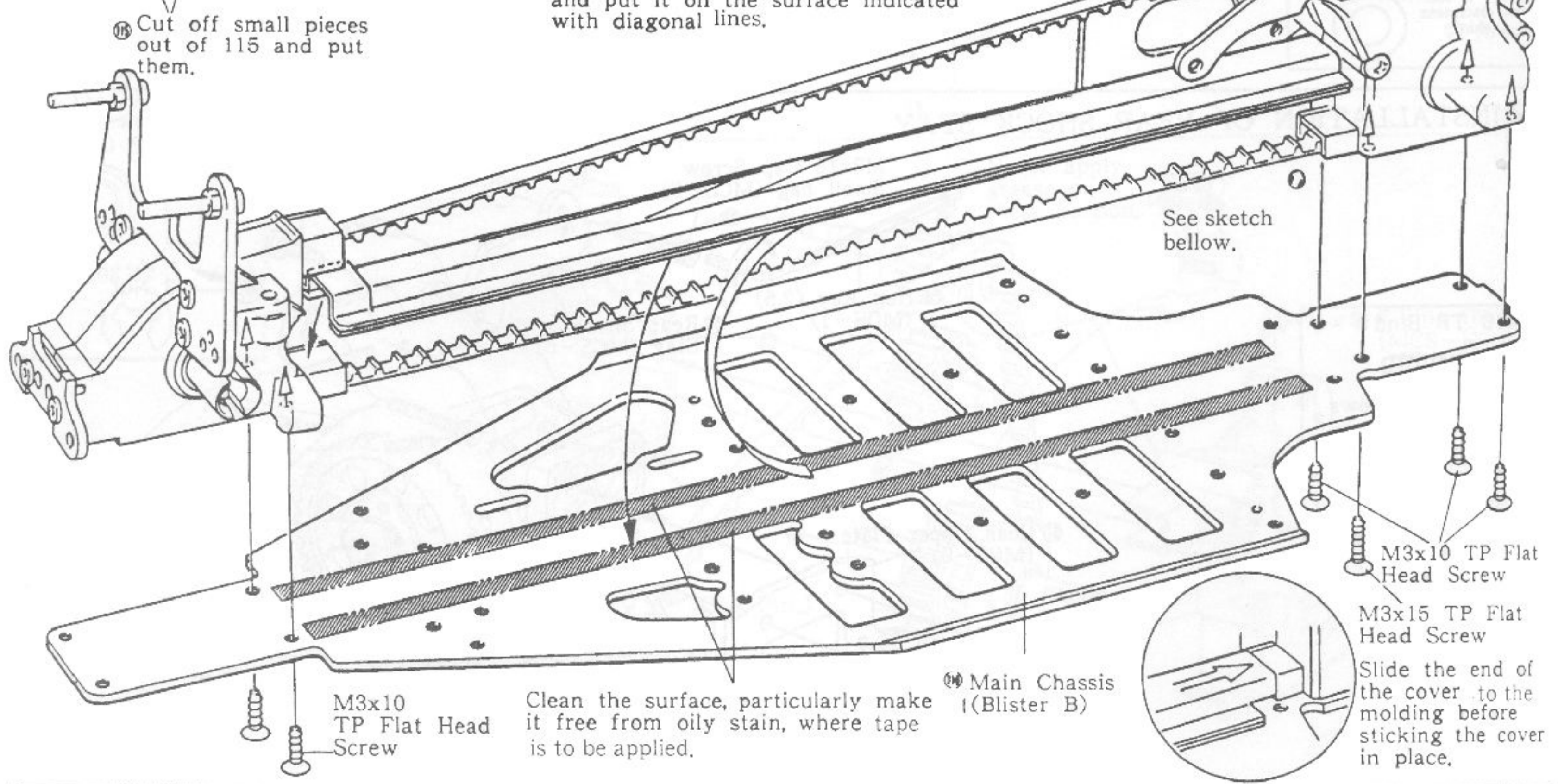

8 INSTALLATION OF REAR SUSPENSION ARM

STAGE 1

Stick the sponge parts to the side of the pivot, as shown, then the center part in ward.

② Sponge Tape (MCS-2)

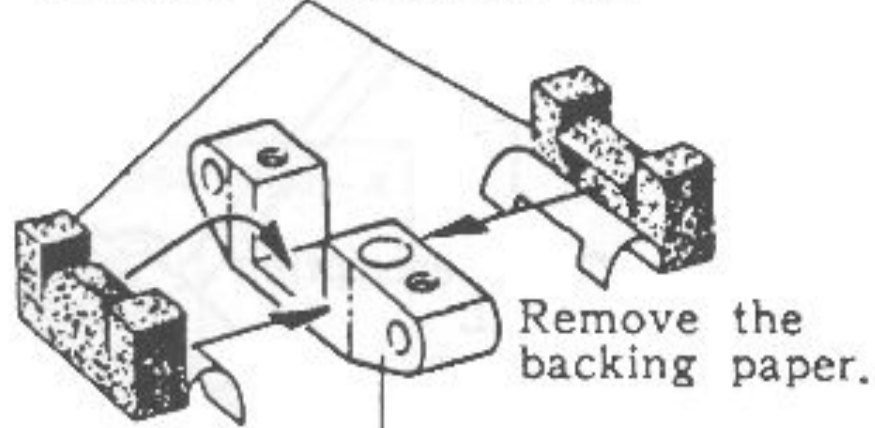

Remove the backing paper.

⑦ Rear Suspension Pivot (MCS-6)

STAGE 2

④ E Ring (E2.5) (MCS-1)

⑧ Rear Sus. Shaft (B) (MCS-7)
Length: 58mm

M3x10 TP Flat Head Screws ... 2
M3x10 TP Bind Screws ... 2

④ E Rings (E2.5) ... 4

⑧ Rear Sus. Shafts (B) ... 2

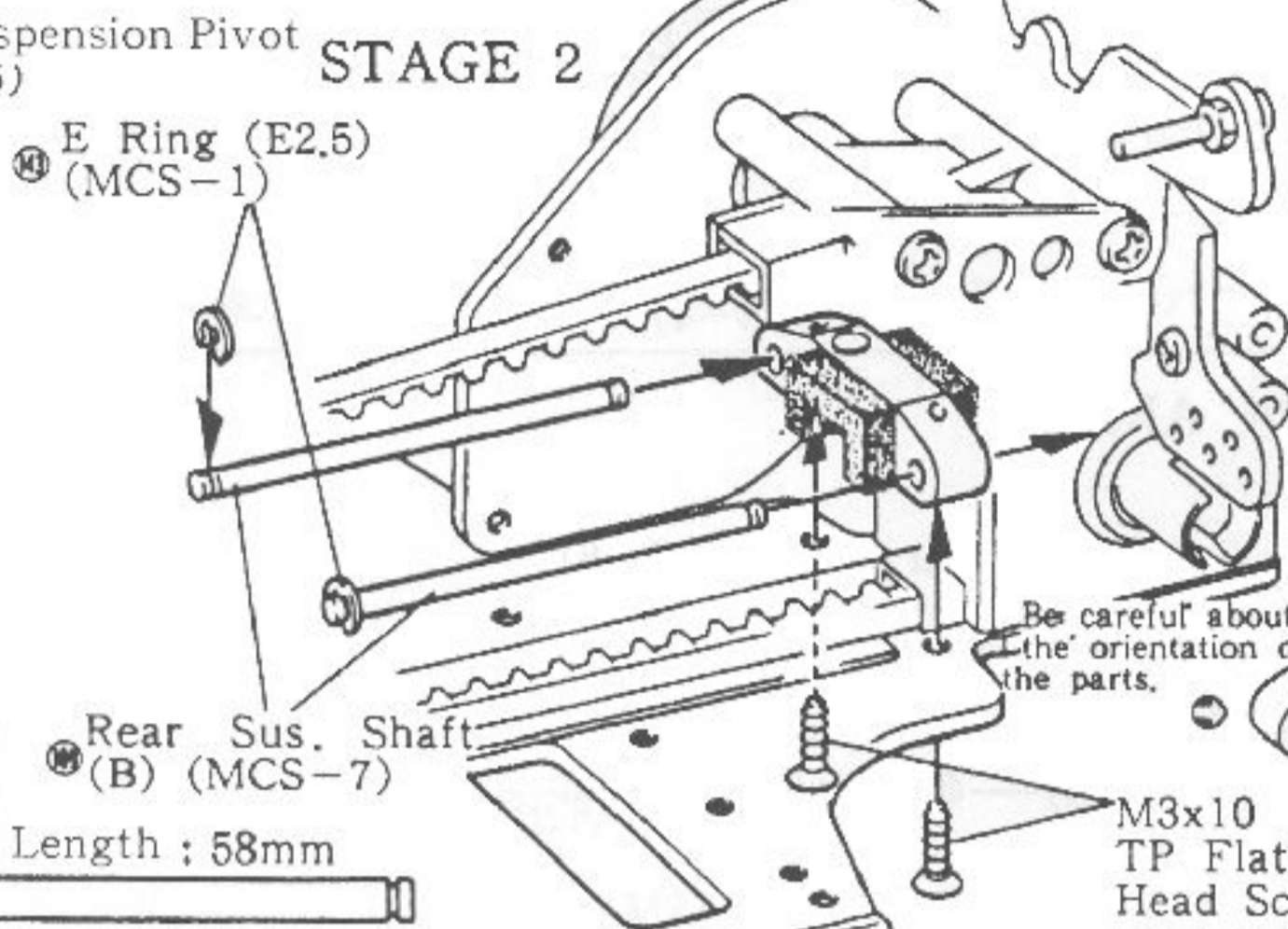
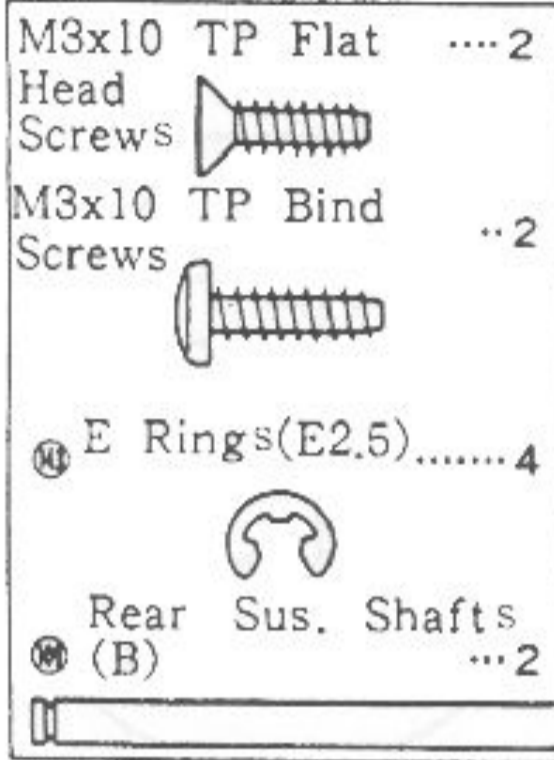

Be careful about the orientation of the parts.

M3x10 TP Flat Head Screw

STAGE 3

Be careful about orientation of the parts.

⑧ Rear Sus. Plate (MCS-5)

④ E Ring (E2.5)

M3x10 TP Bind Screw

⑩ Rear Sus. Arm (MCS-8)

④ E Ring (E2.5) (MCS-1)

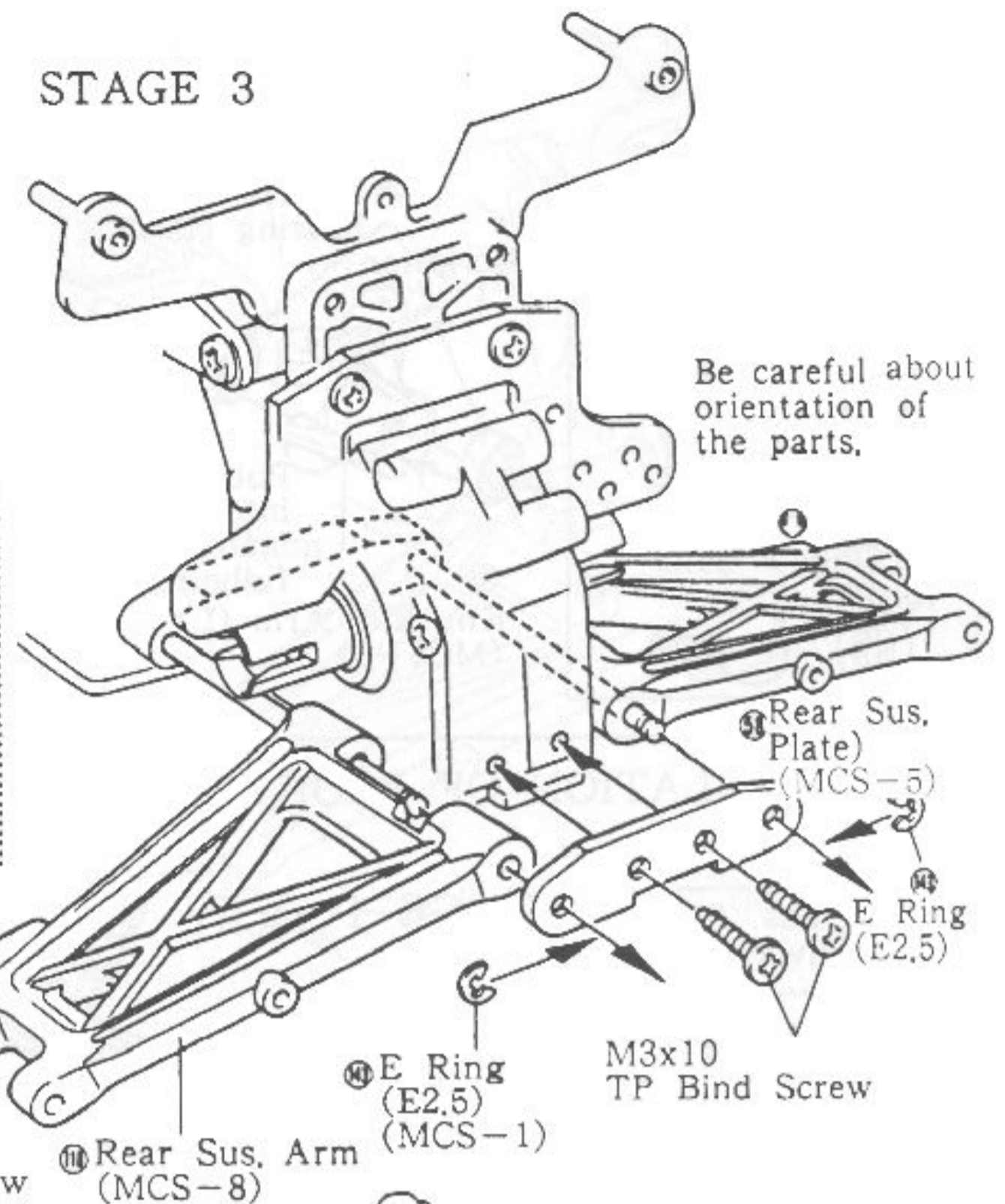

9 INSTALLATION OF CHASSIS (UPPER)

M3x6 Flat Head Screws ... 4

M3x6 TP Flat Head Screws ... 2

M3x10 TP Flat Screws ... 4

M3x10 TP Bind Screw ... 1

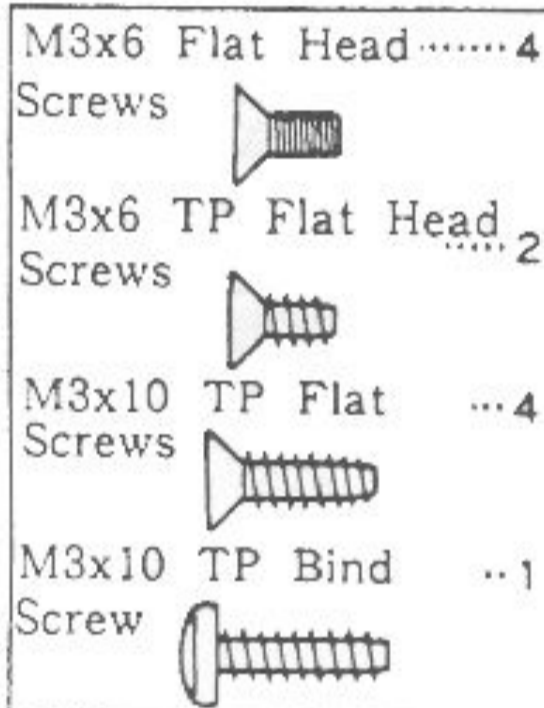

⑨ Servo Saver Shaft (MCS-4)

⑩ Upper Deck Post (MCS-4)

⑦ Belt Cover Stopper (MCS-6)

⑦ Upper Deck Mount (MCS-6)

3x10 TP Flat Head Screw

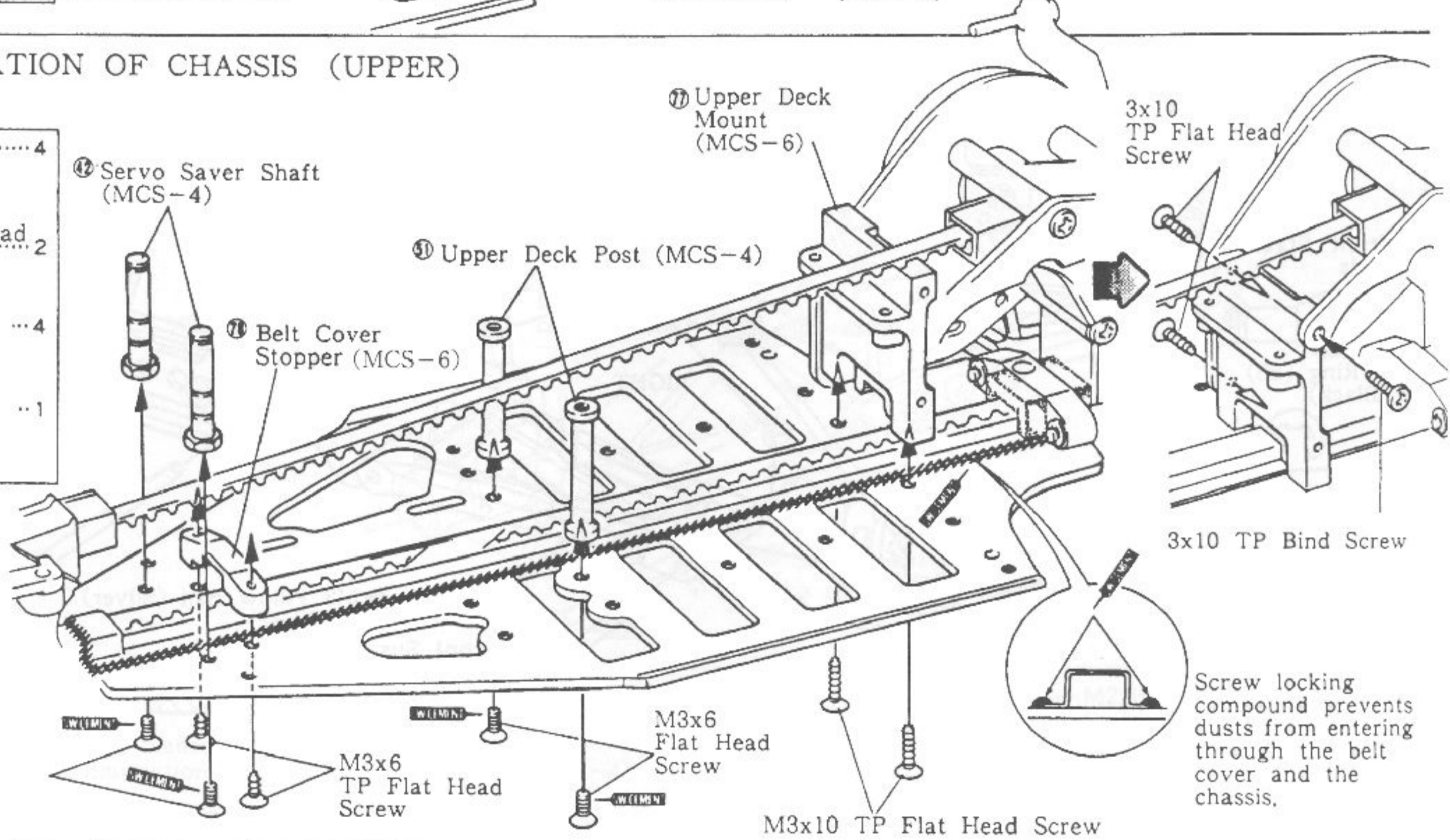

3x10 TP Bind Screw

Screw locking compound prevents dusts from entering through the belt cover and the chassis.

M3x6 Flat Head Screw

M3x6 TP Flat Head Screw

M3x6 Flat Head Screw

M3x10 TP Flat Head Screw

10 INSTALLATION OF BATTERY HOLDER • SEPARATE TYPE

⑩ Stopper Post (MCS-6)

The size of the screw and the parts to be installed will differ depend on the kind of battery that will be used.

• Separate Type

M3x10 TP Flat Head Screws ... 4

• Stick Type

M3x6 TP Flat Head 4 Screws

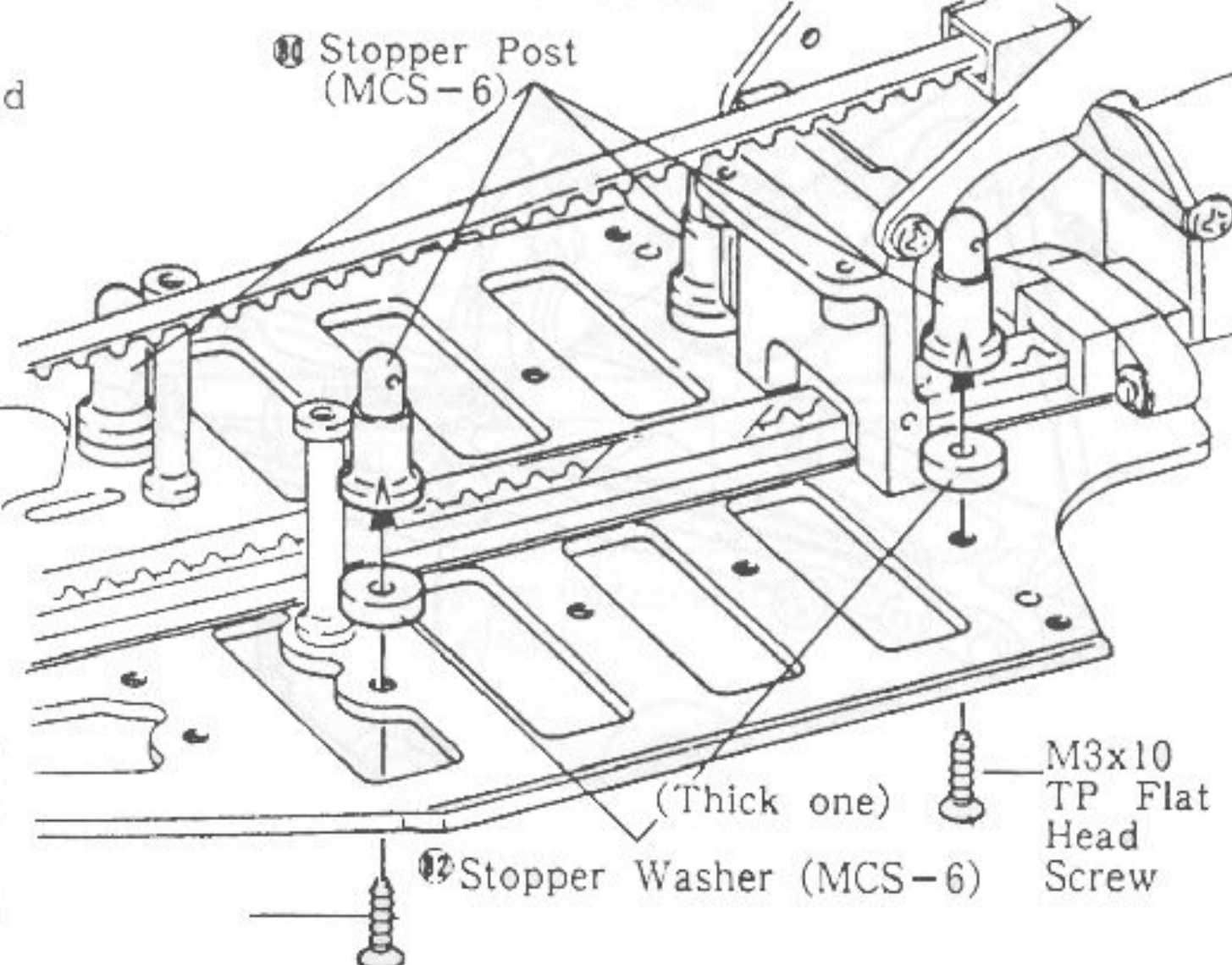

(Thick one)

M3x10 TP Flat Head Screw

⑩ Stopper Washer (MCS-6)

• STICK TYPE

⑩ Battery Holder (MCS-6)

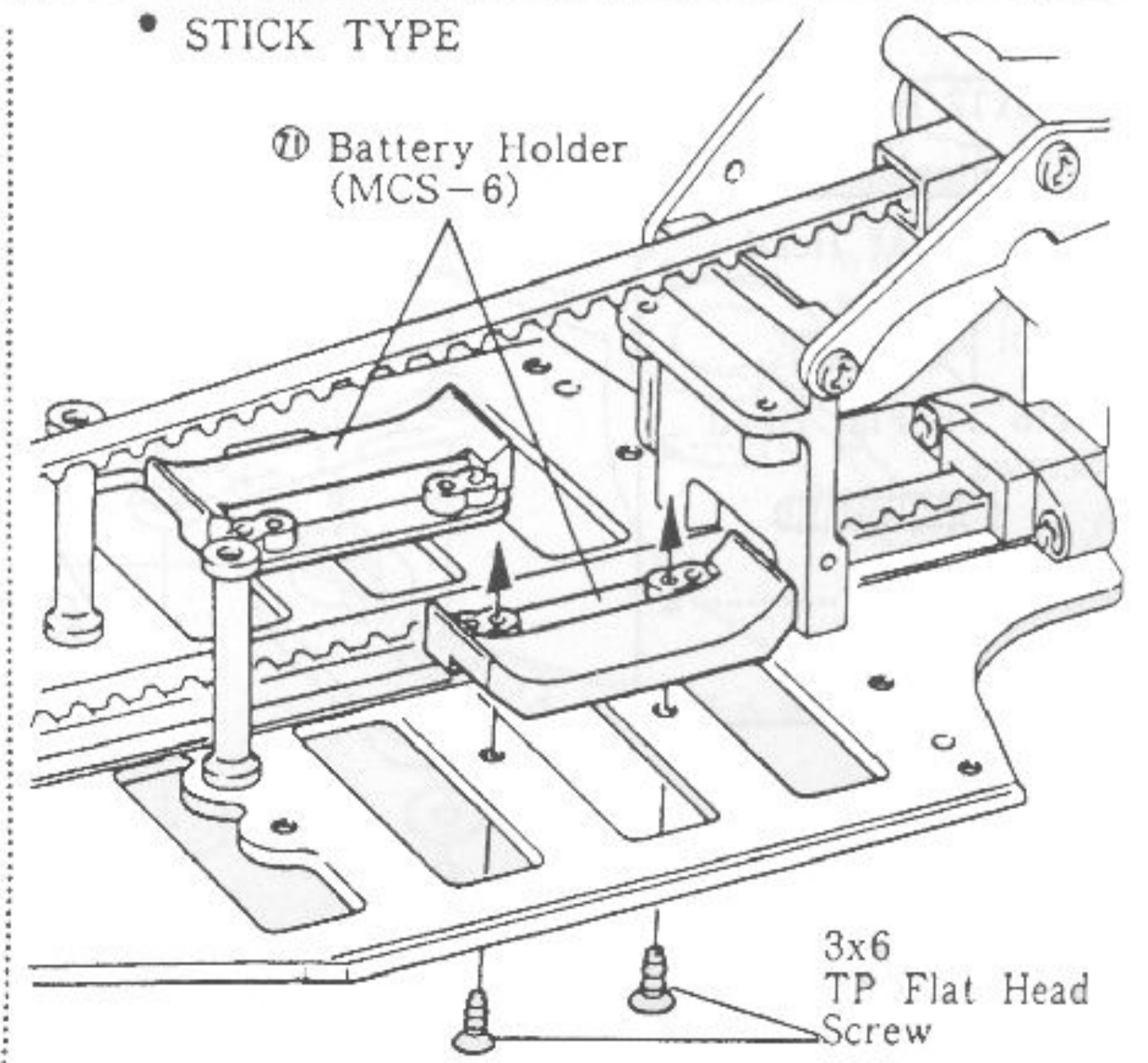

3x6 TP Flat Head Screw

11 ASSEMBLY OF KNUCKLE ARM

STAGE 1 RIGHT

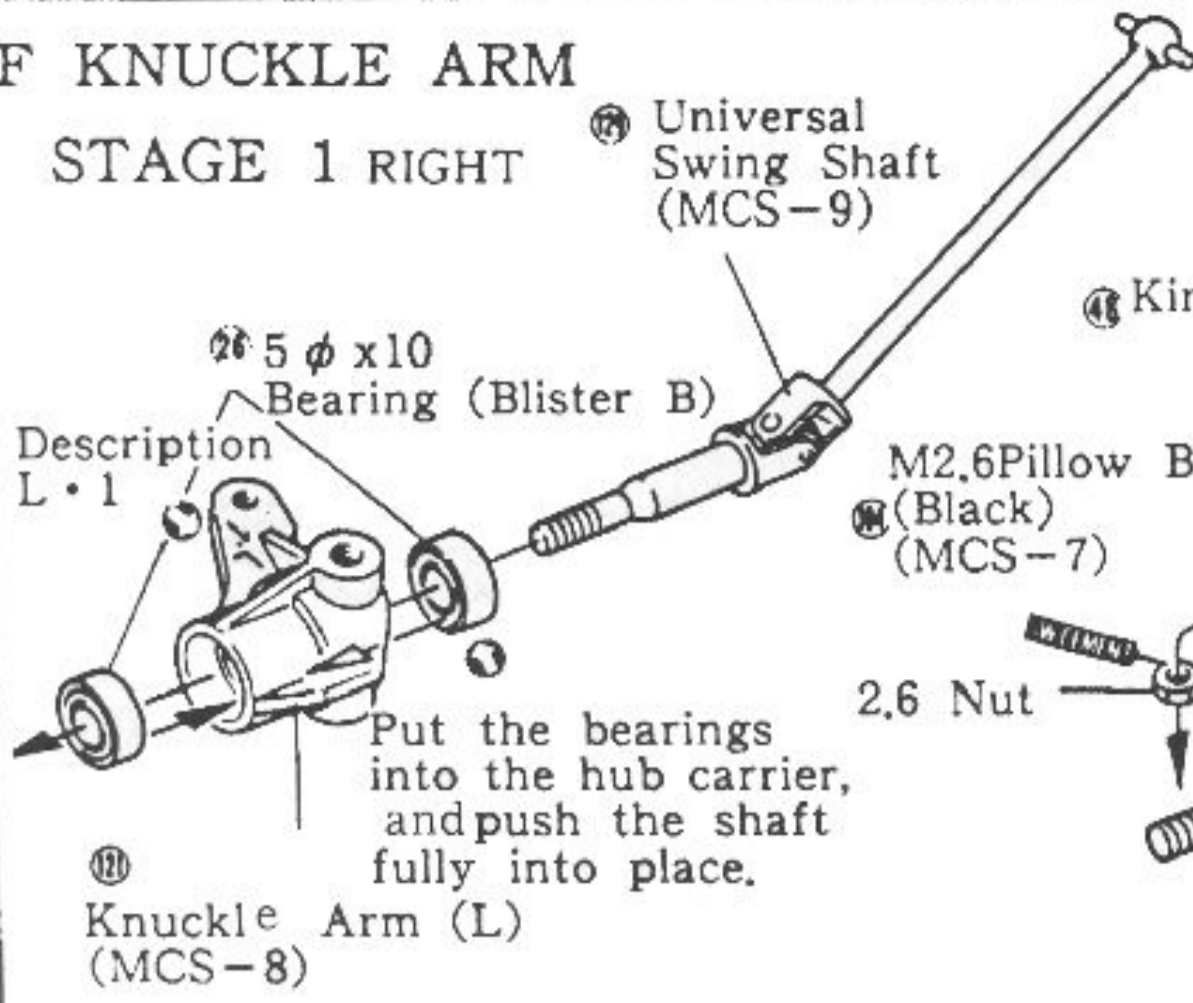
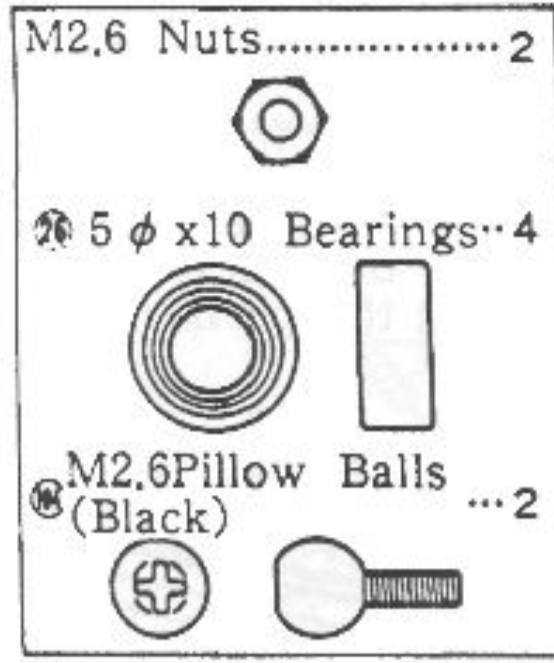

STAGE 2 Description R

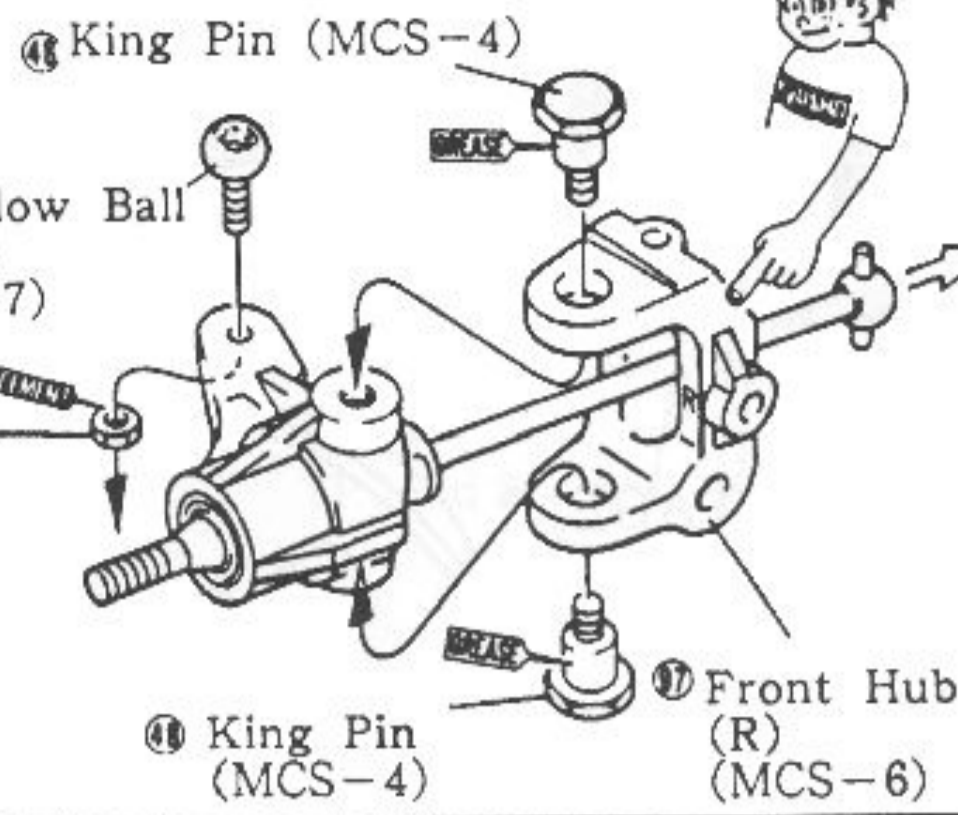

STAGE 3 LEFT

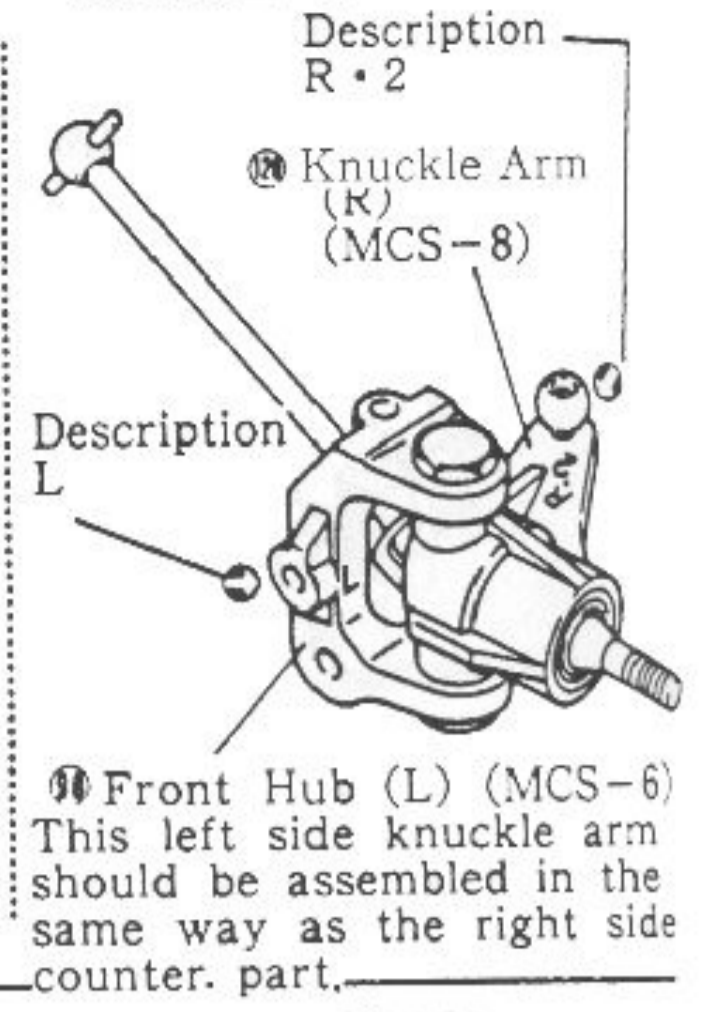

12 INSTALLATION OF FRONT SUSPENSION ARM

STAGE 1 RIGHT

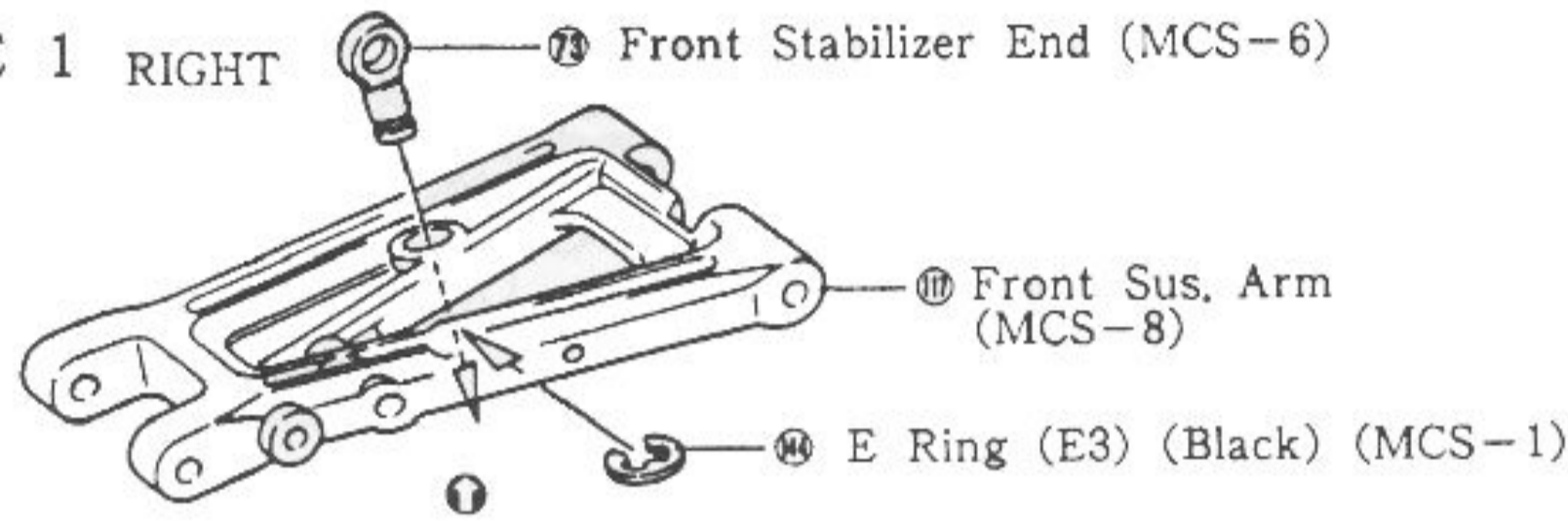

STAGE 2

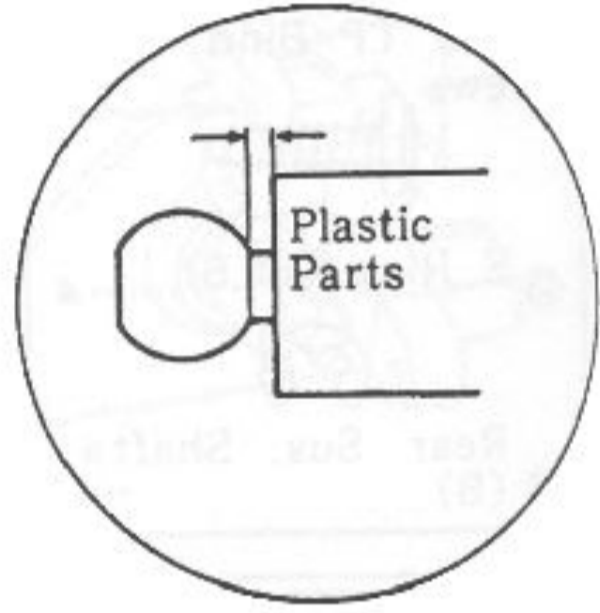
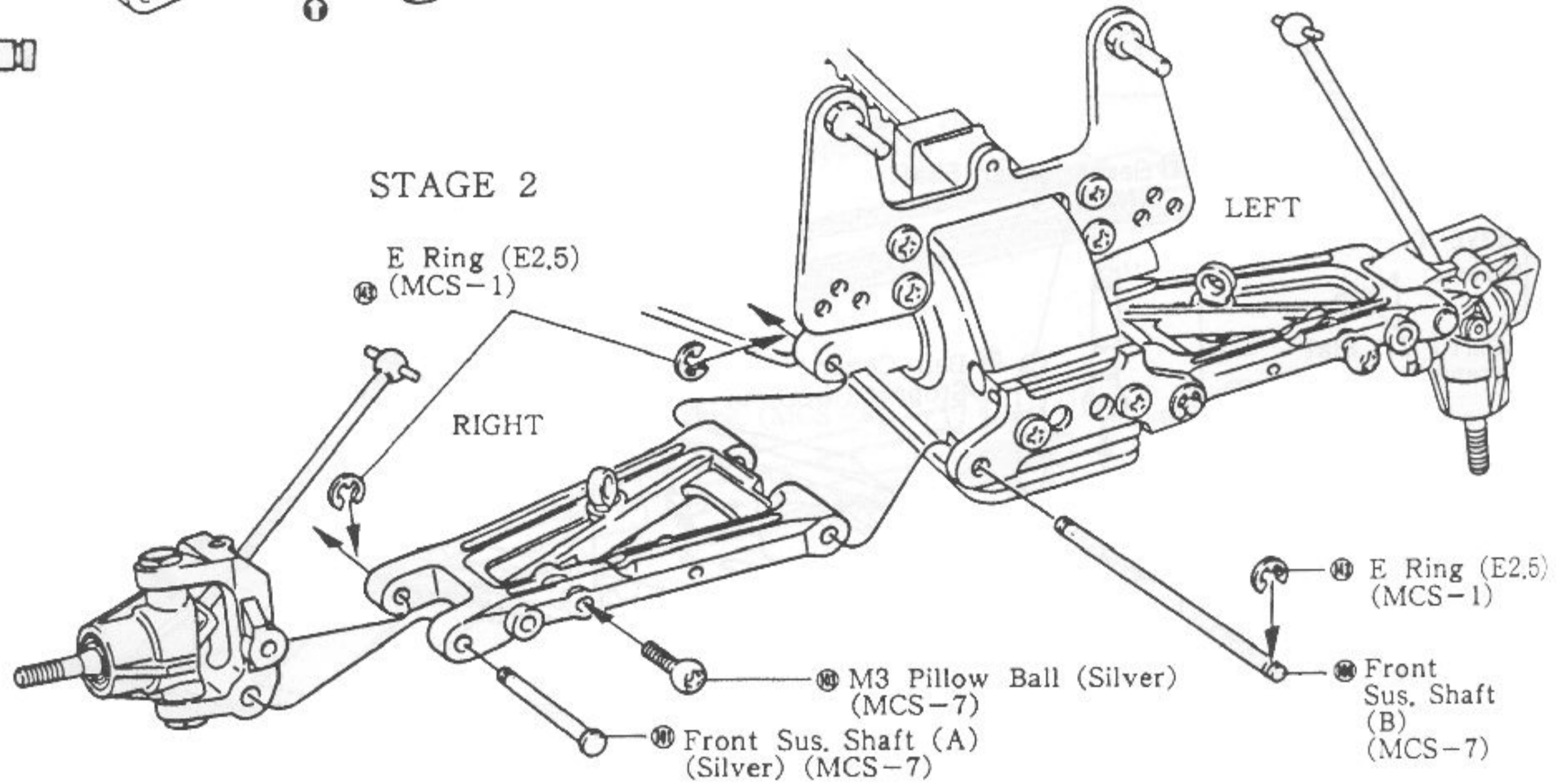

13 INSTALLATION OF FRONT UPPER ROD

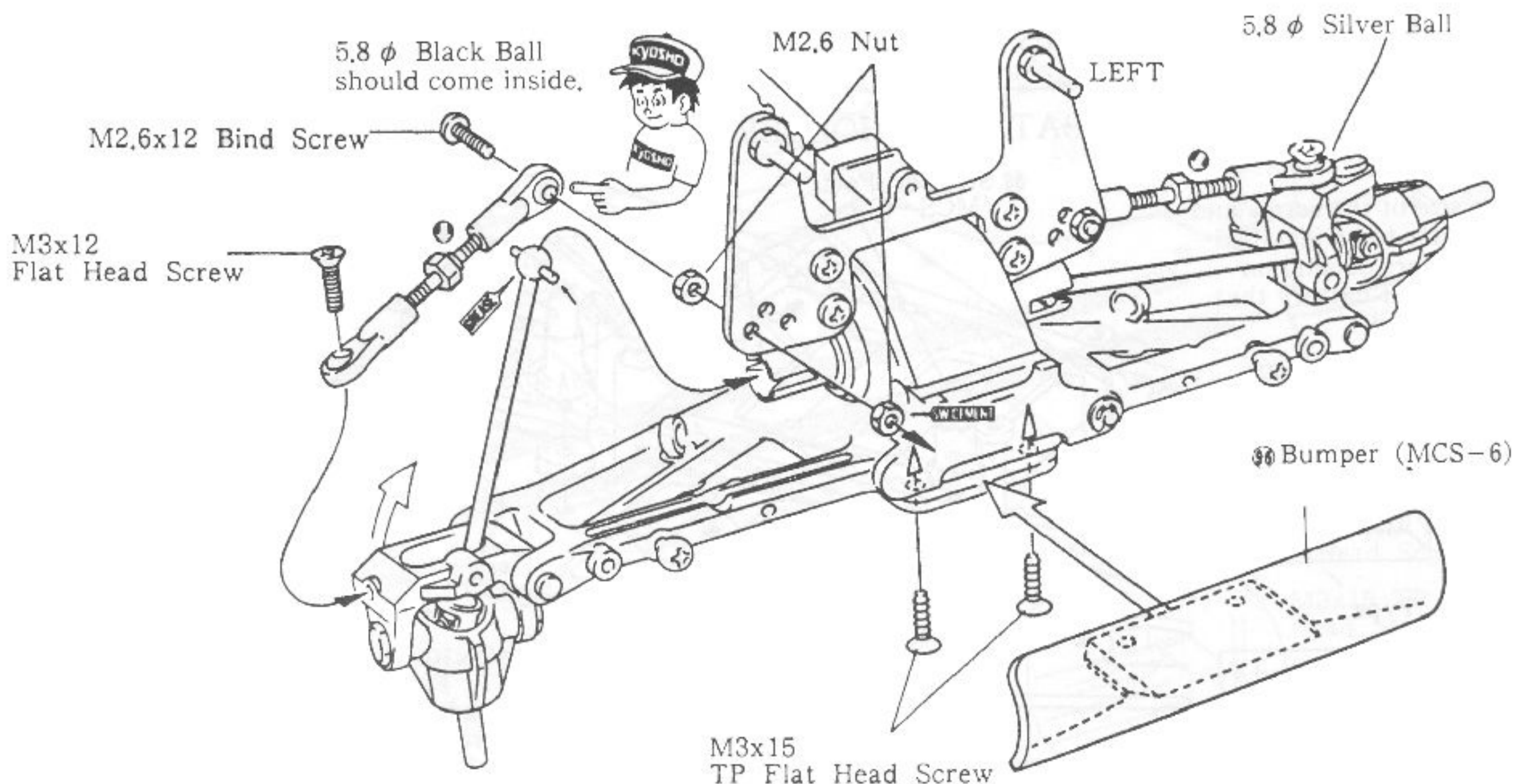
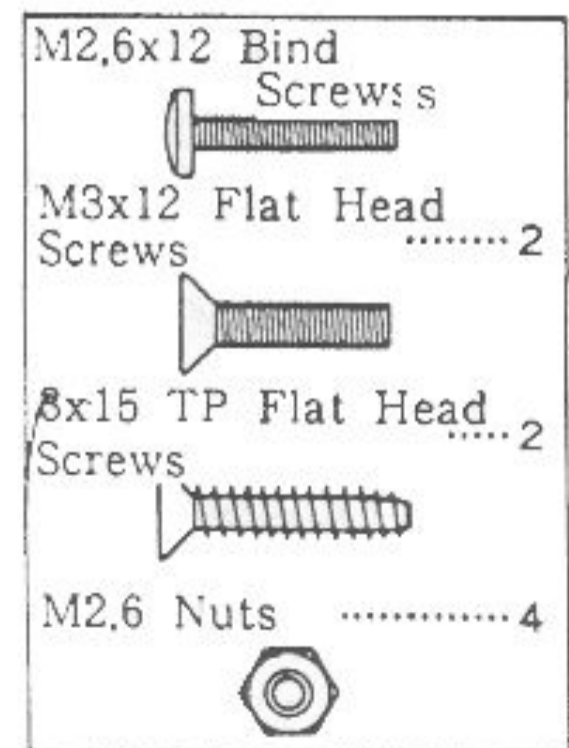

14 INSTALLATION OF REAR HUB STAGE 1

- ④ 5 φ X10 Bearings... 4
- ⑤ Rear Shafts (A) (Black) ... 2
- ⑥ M3 Pillow Balls (Wilver) 2
- ⑦ E Ring (E2,5) 2

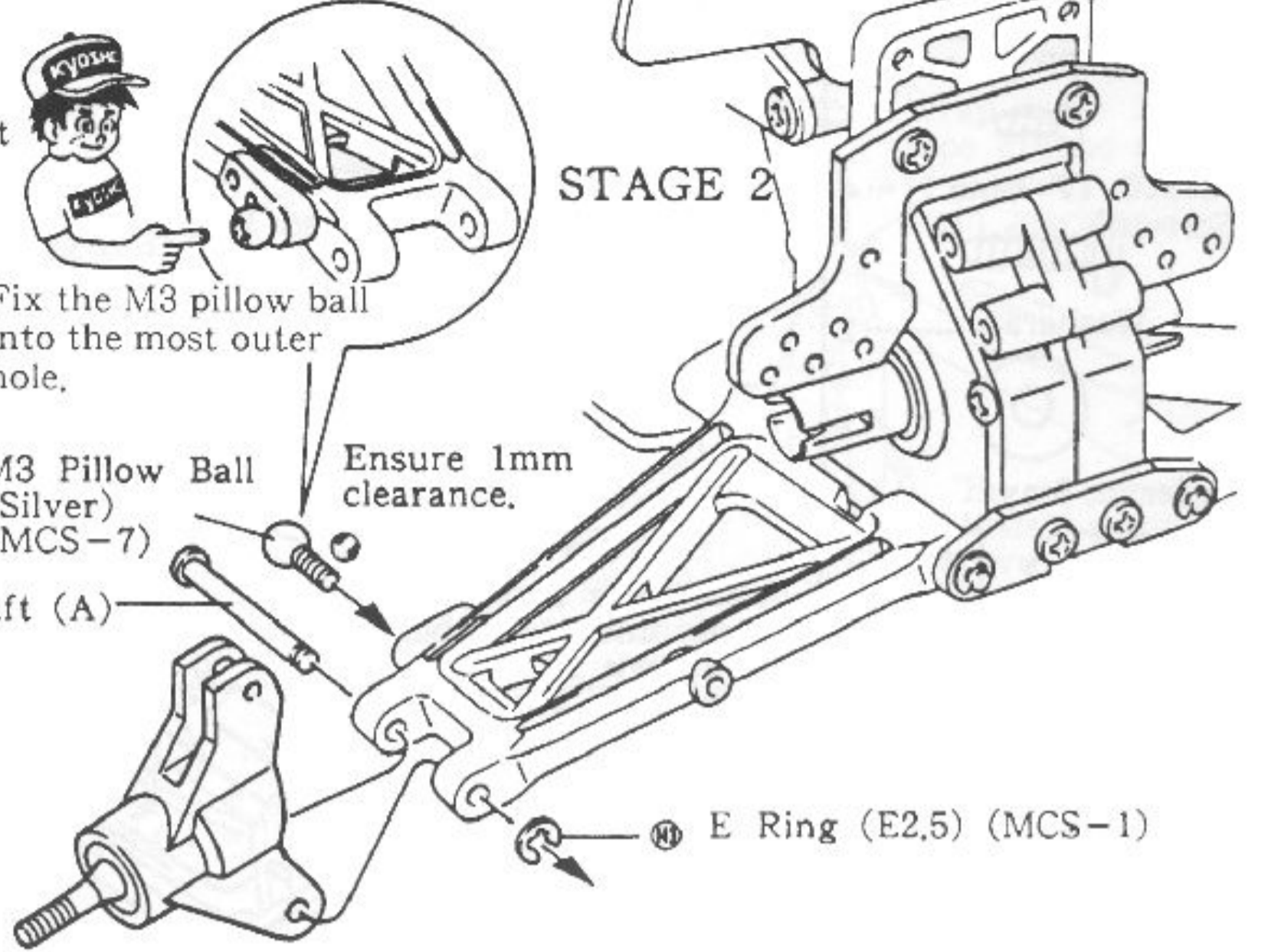
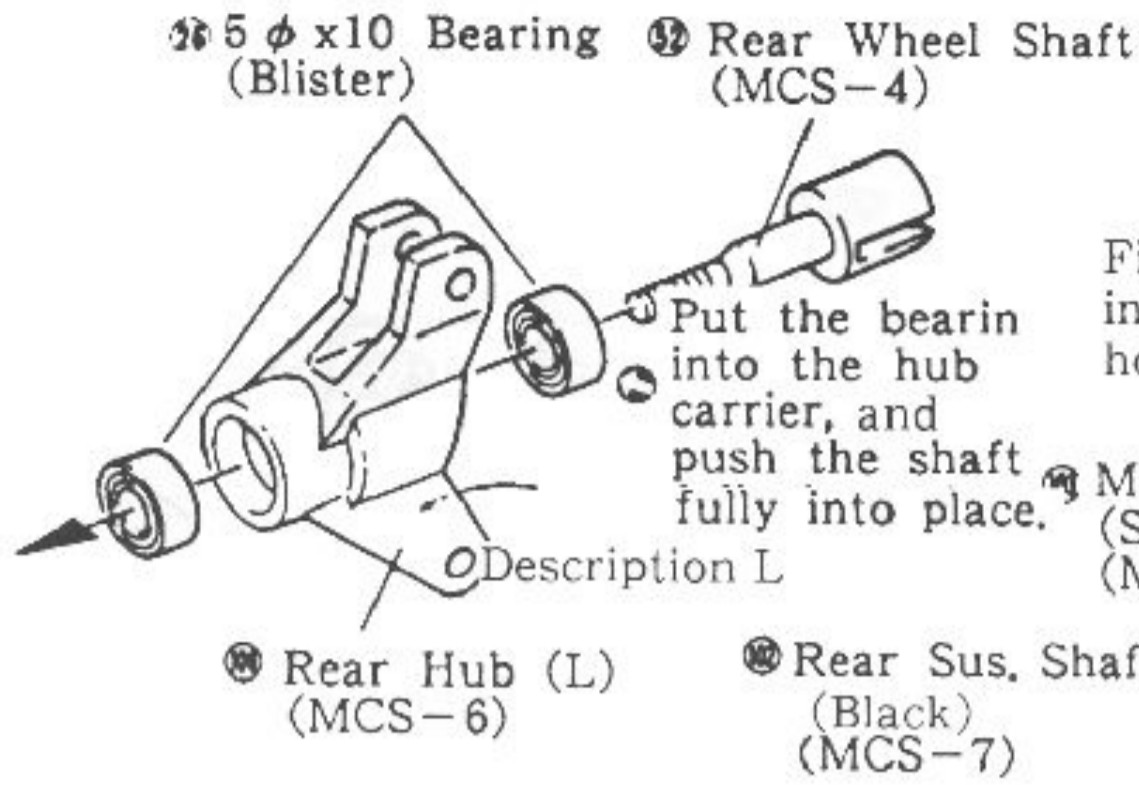

15 INSTALLATION OF REAR UPPER ROD

- M2.6x12 Bind Screws 2
- M3x10 Bind Screws 2
- M2.6 Nuts 4

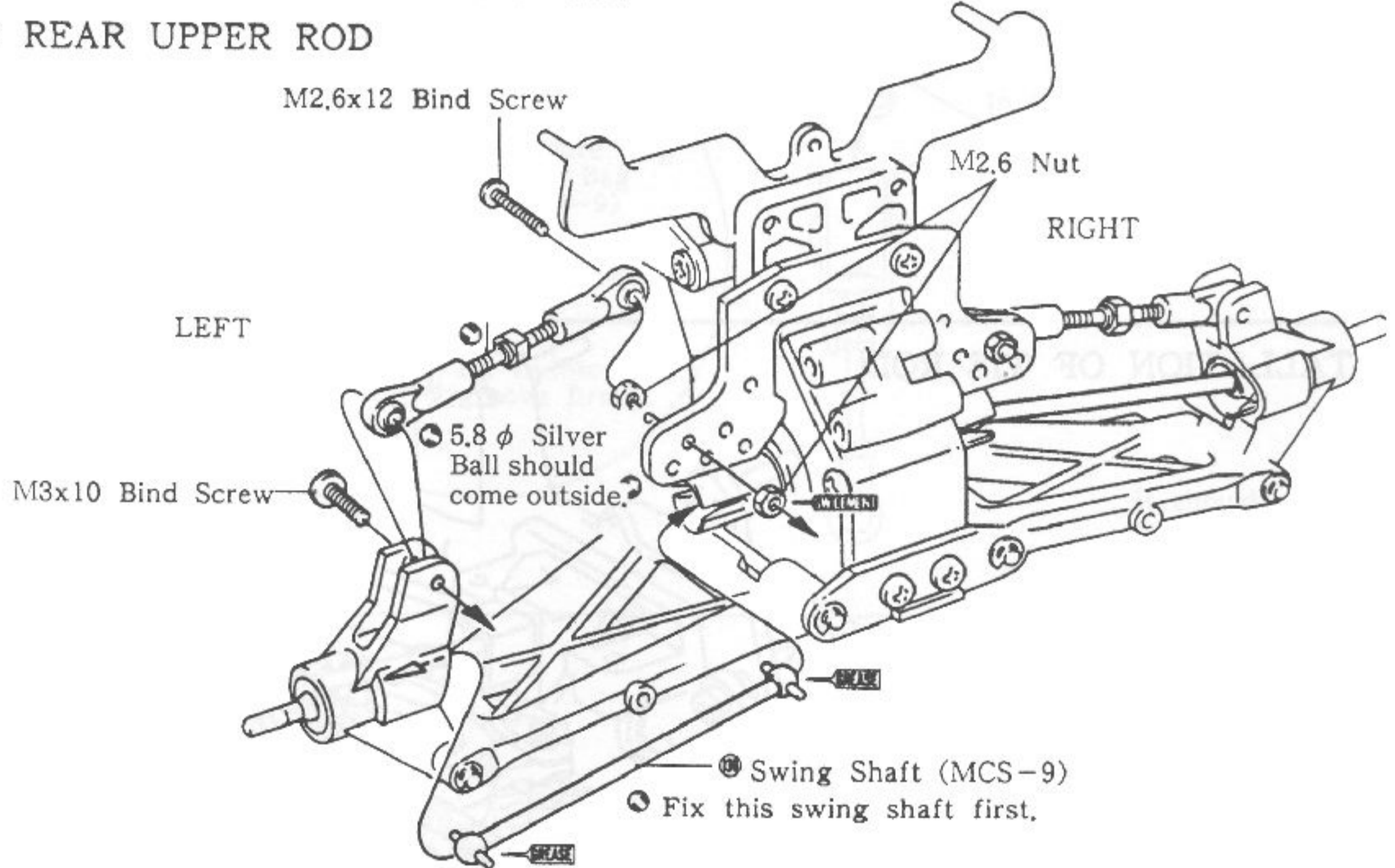

16 ASSEMBLY OF SERVO SAVER

- ⑧ Ball End (S) (MCS-7)

Cut off the shaded area to match illustration.

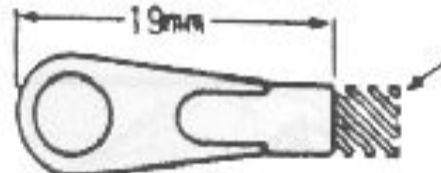

- M2.6x6 Bind Screw.. 1
- 2.6 φ Washers (Black) 4
- ⑨ Ball Nuts 3
- M2.6 Pillow Balls (Black) ... 2
- ⑩ Ball Ends (S) 2
- M2x10 Shaft 1

STAGE 1

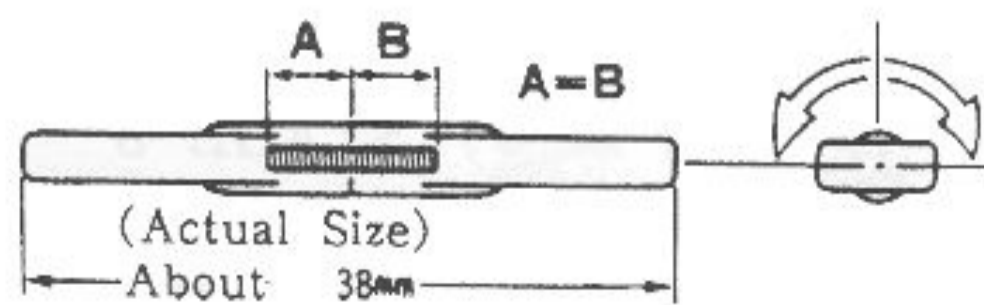
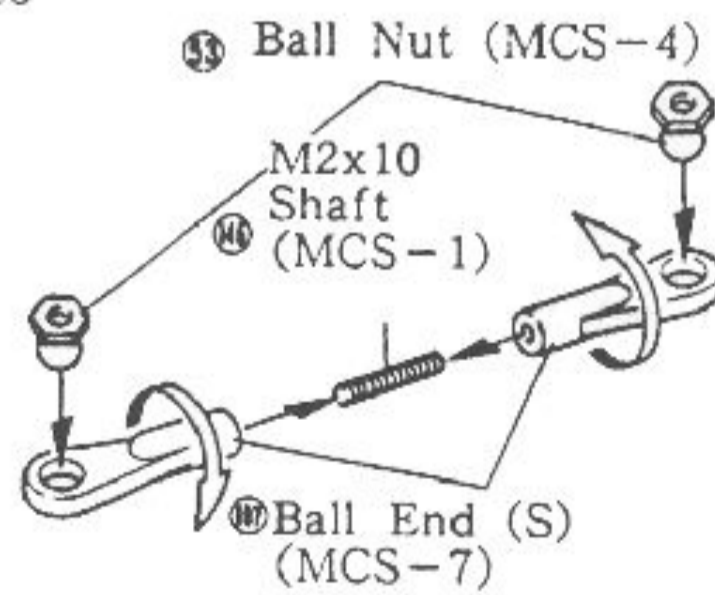

STAGE 2 Cut away the unnecessary with a pair of clippers.

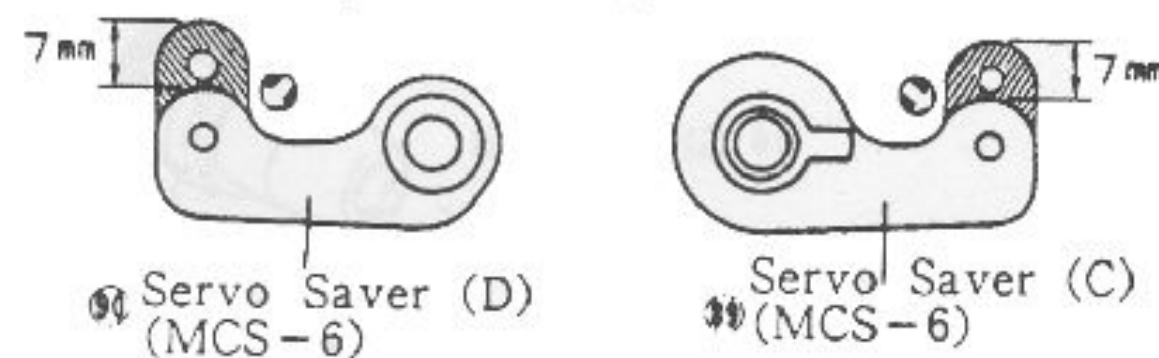

STAGE 3

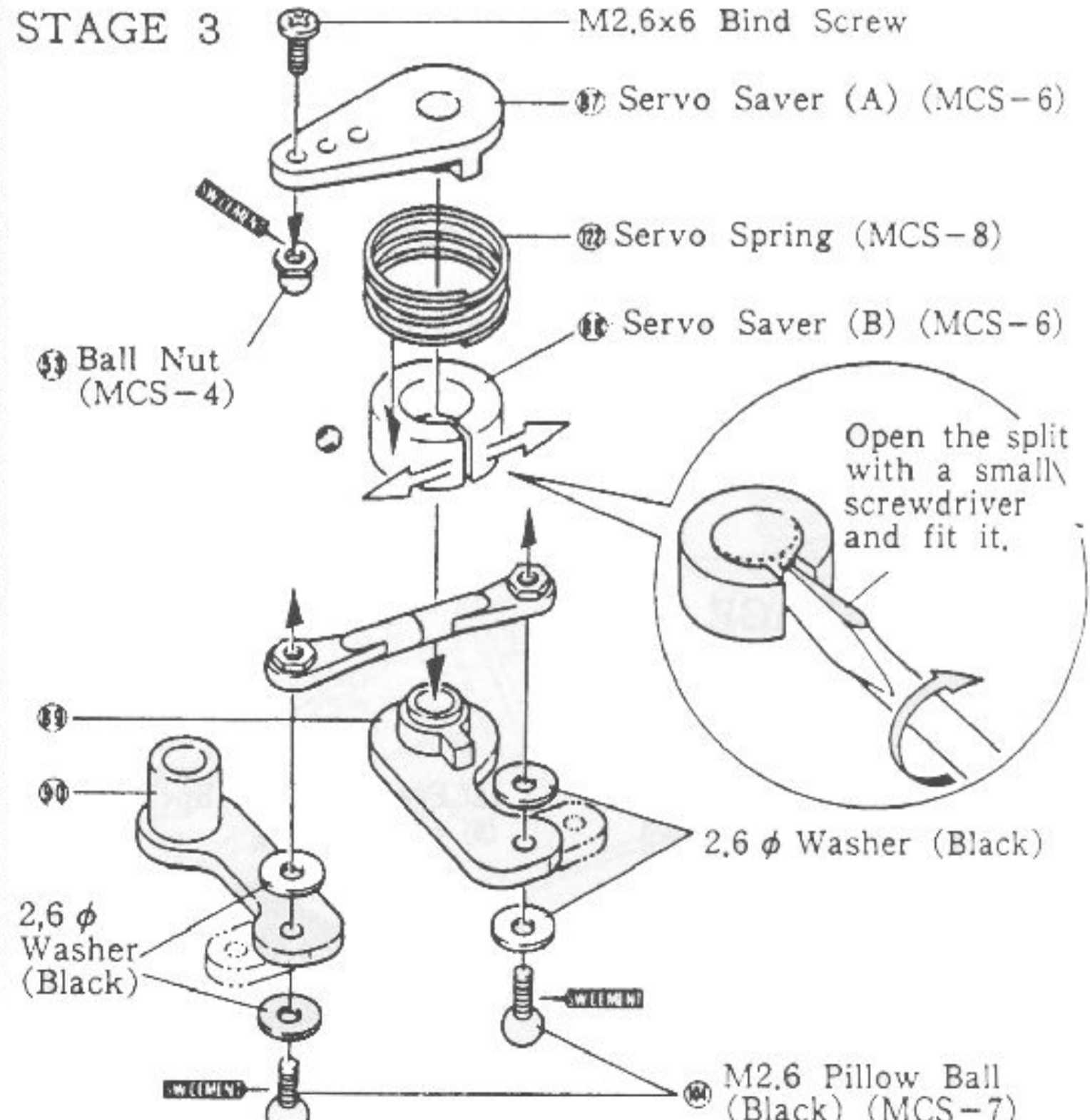

17 INSTALLATION OF SERVO SAVER

- M2.6x6 TP Flat Head Screw ... 1
- M3x10 TP Bind Screws ... 4
- M3 Washers ... 2
- Servo Stay Spacer ... 2
- Servo Saver Collars ... 2
- E Rings (E4) ... 2
- 5 φ Shims ... 2

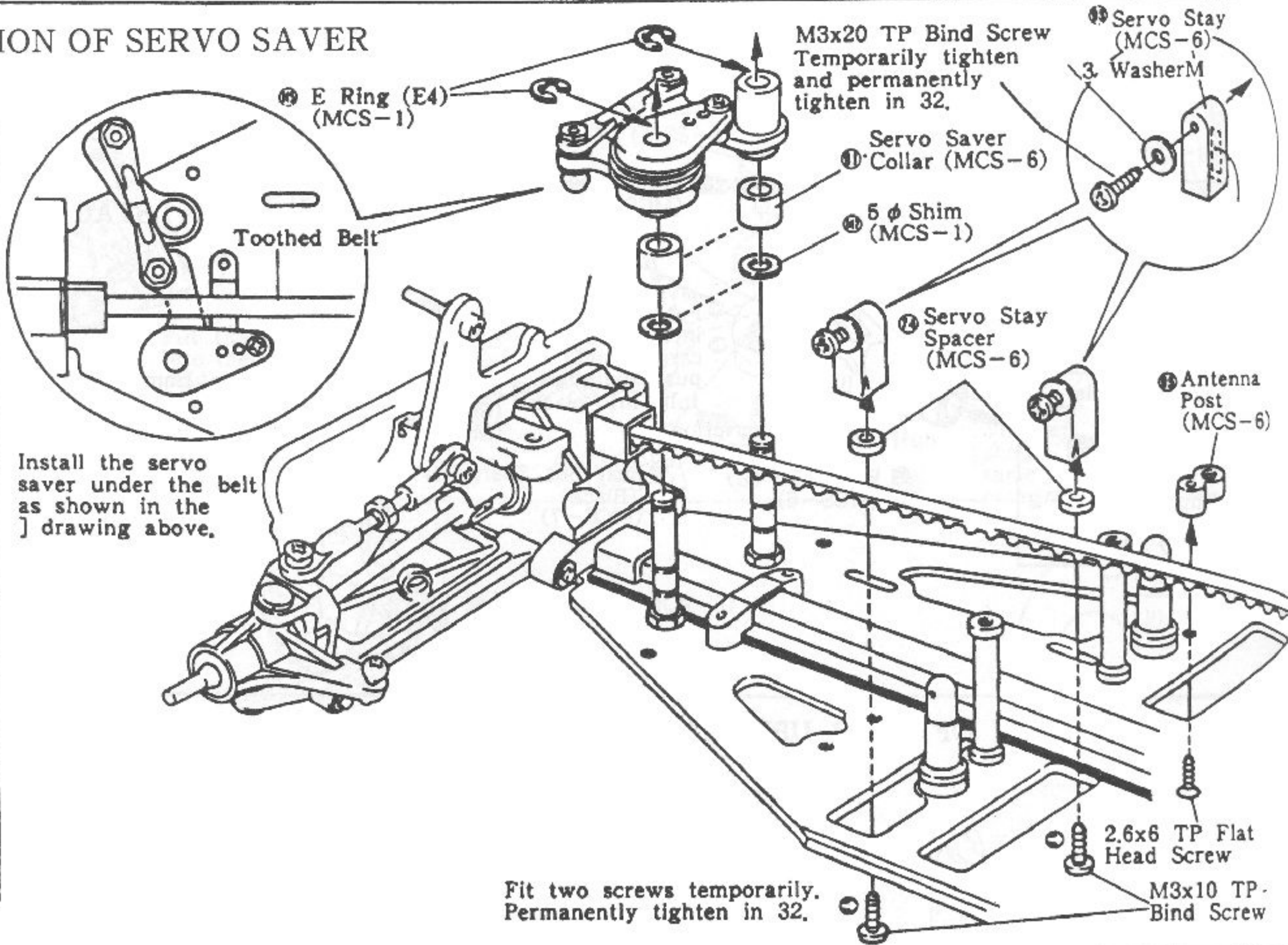

18 INSTALLATION OF TIE ROD

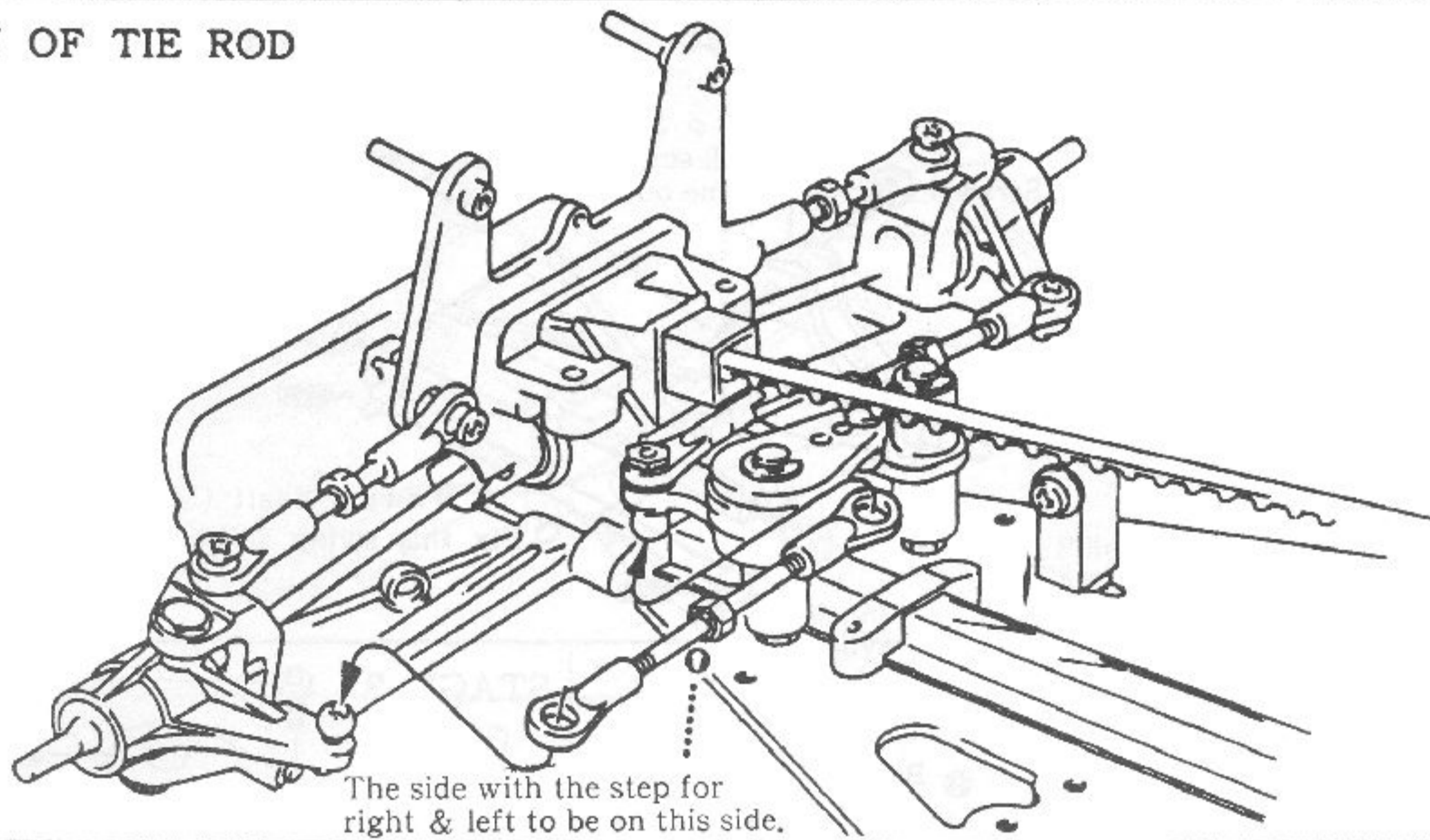

19 DISASSEMBLY OF SHOCK

Shock are assembled temporarily, and must be disassembled to add parts and oil.

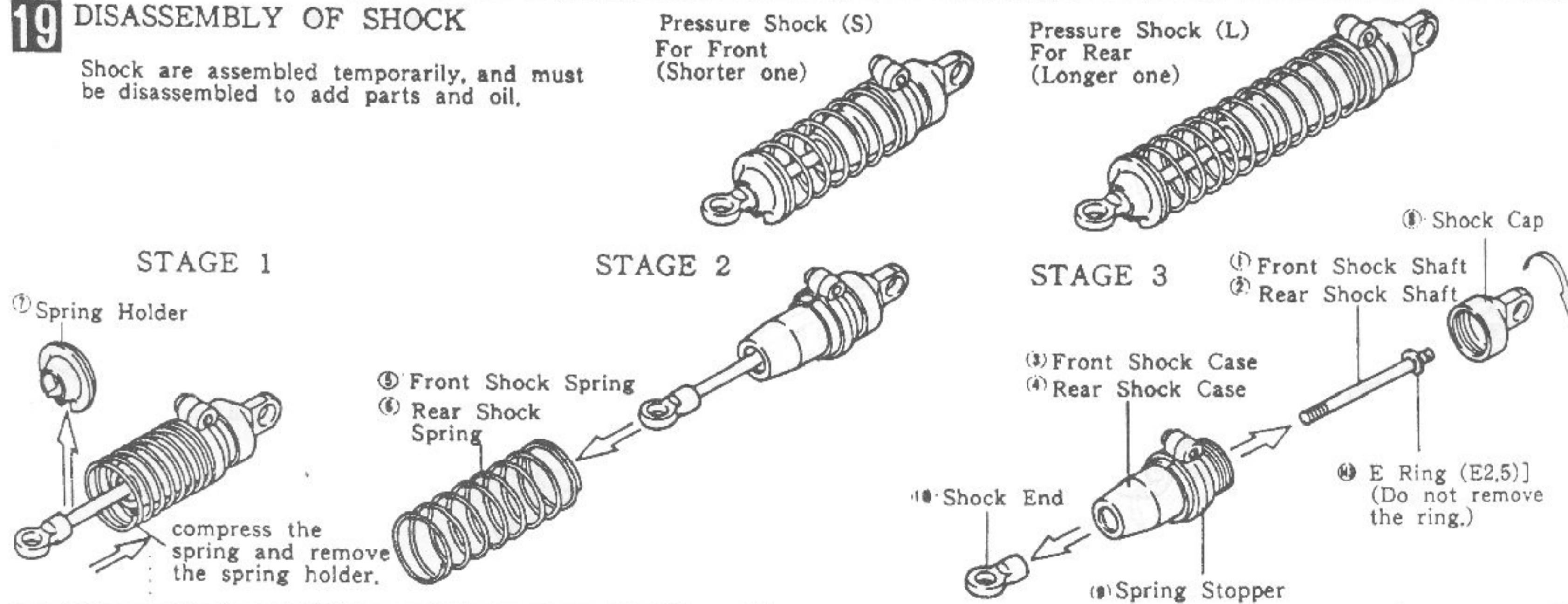

20 ASSEMBLY OF SHOCK

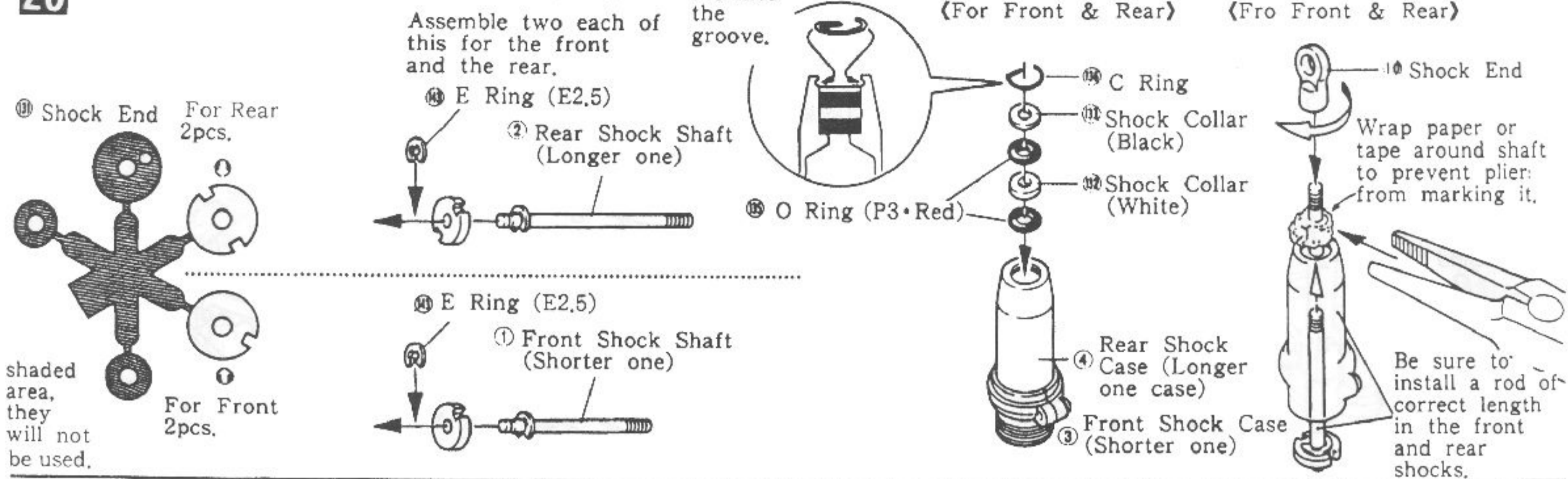

21 FILLING THE SHOCK OIL

STAGE 1 Pull down the piston to the bottom and pour oil slowly. Then move the piston up and down gently to get rid of air bubbles.

① Shock Oil (MCS-2)

Pull the cylinder to slightly above the brim.

STAGE 2 Keep the piston in the lowest position and tight 2 gradually, then excessive oil will run over.

STAGE 3 Confirm that it will work smoothly by moving the piston up and down.

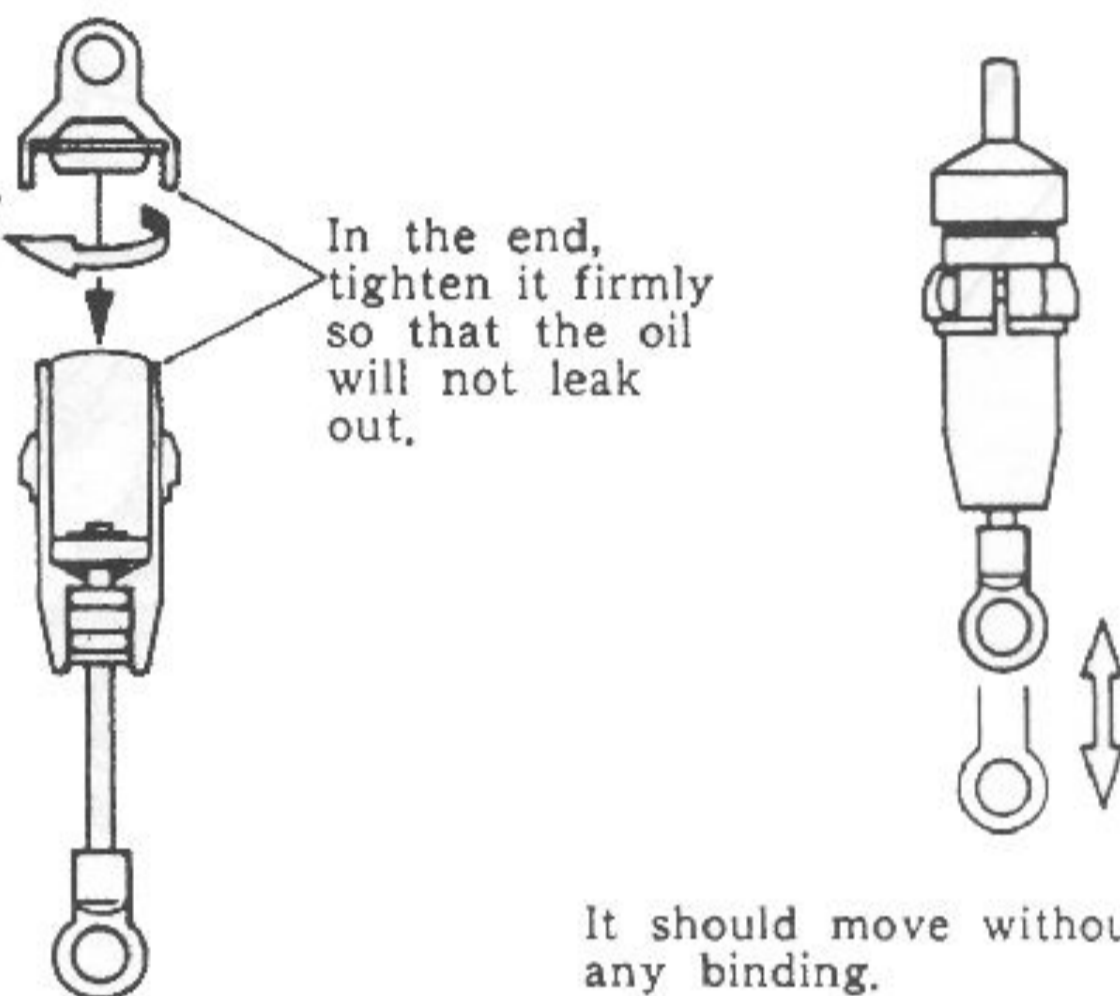
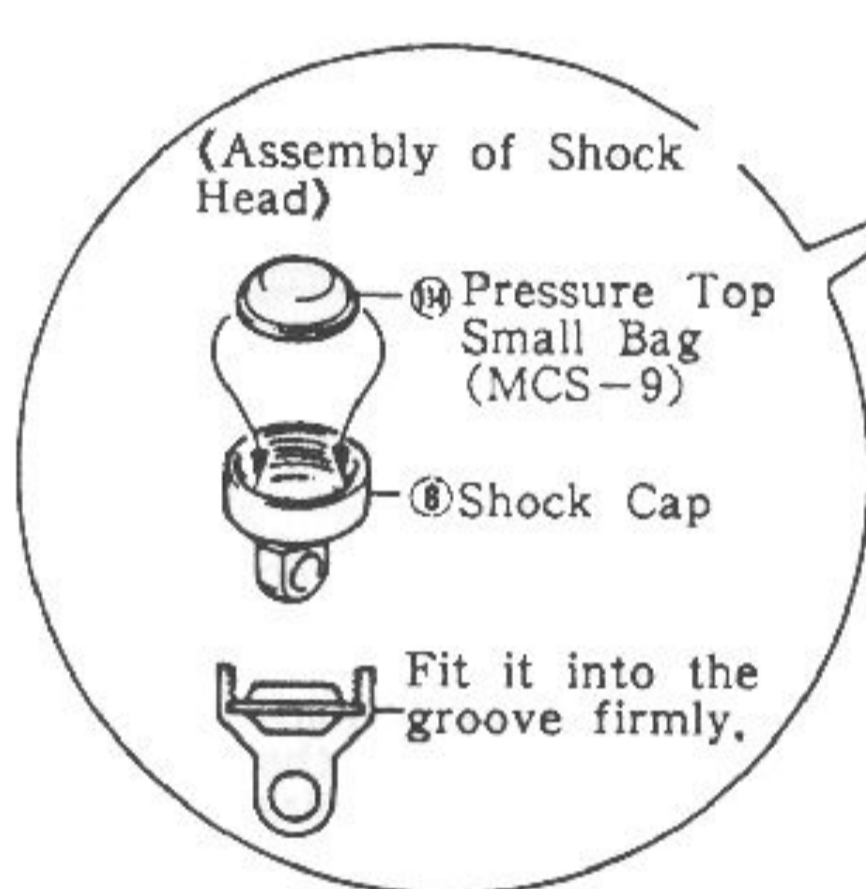
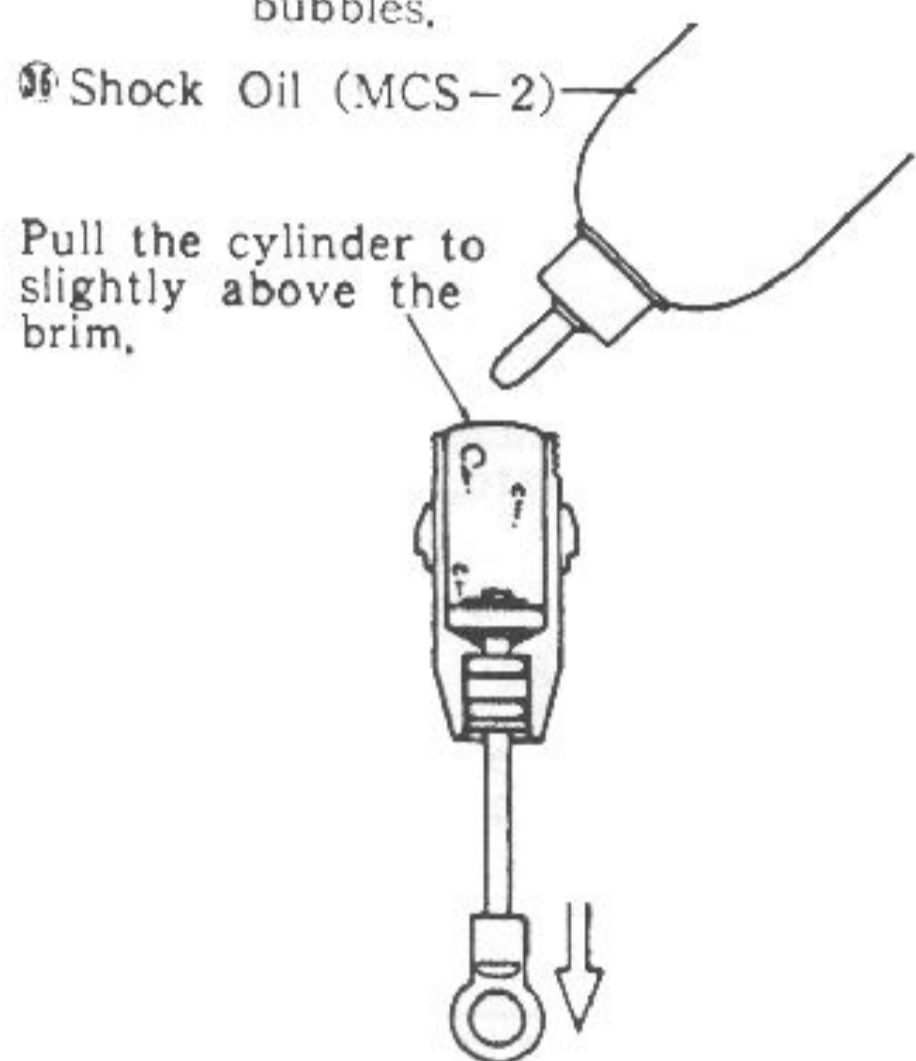

22 INSTALLATION OF SHOCK

(Front)

④ Shock Collar (MCS-6)

Tighten this screw temporarily since the upper part of the shock will be unfastened for a short time in the step 27 "Installation of Motor"

⑤ M3 Plastic Nut (MCS-6)

⑥ Shock Collar (MCS-6)

⑦ M3 Plastic Nut (MCS-6)

Shorter one

Longer one

(Rear)

⑧ M3 Plastic Nuts..... 4

⑨ Shock Collars..... 4

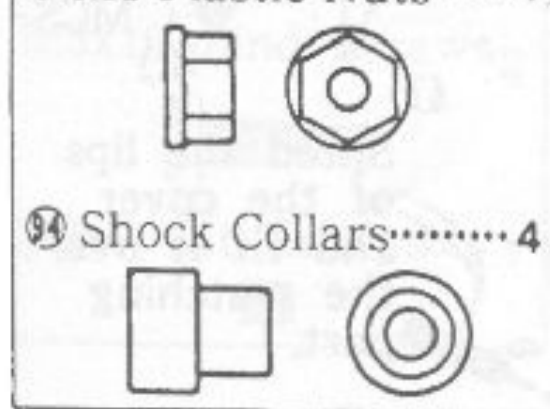

23 INSTALLATION OF UPPER DECK

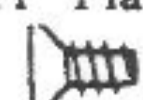
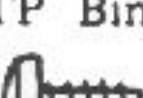
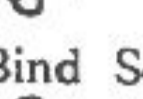
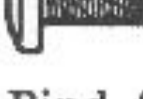
- M3x6 TP Flat Head Screw 
- M3x6 TP Bind Screw ... 1 
- M3x6 Bind Screws... 2 
- M4x12 Bind Screws 2 

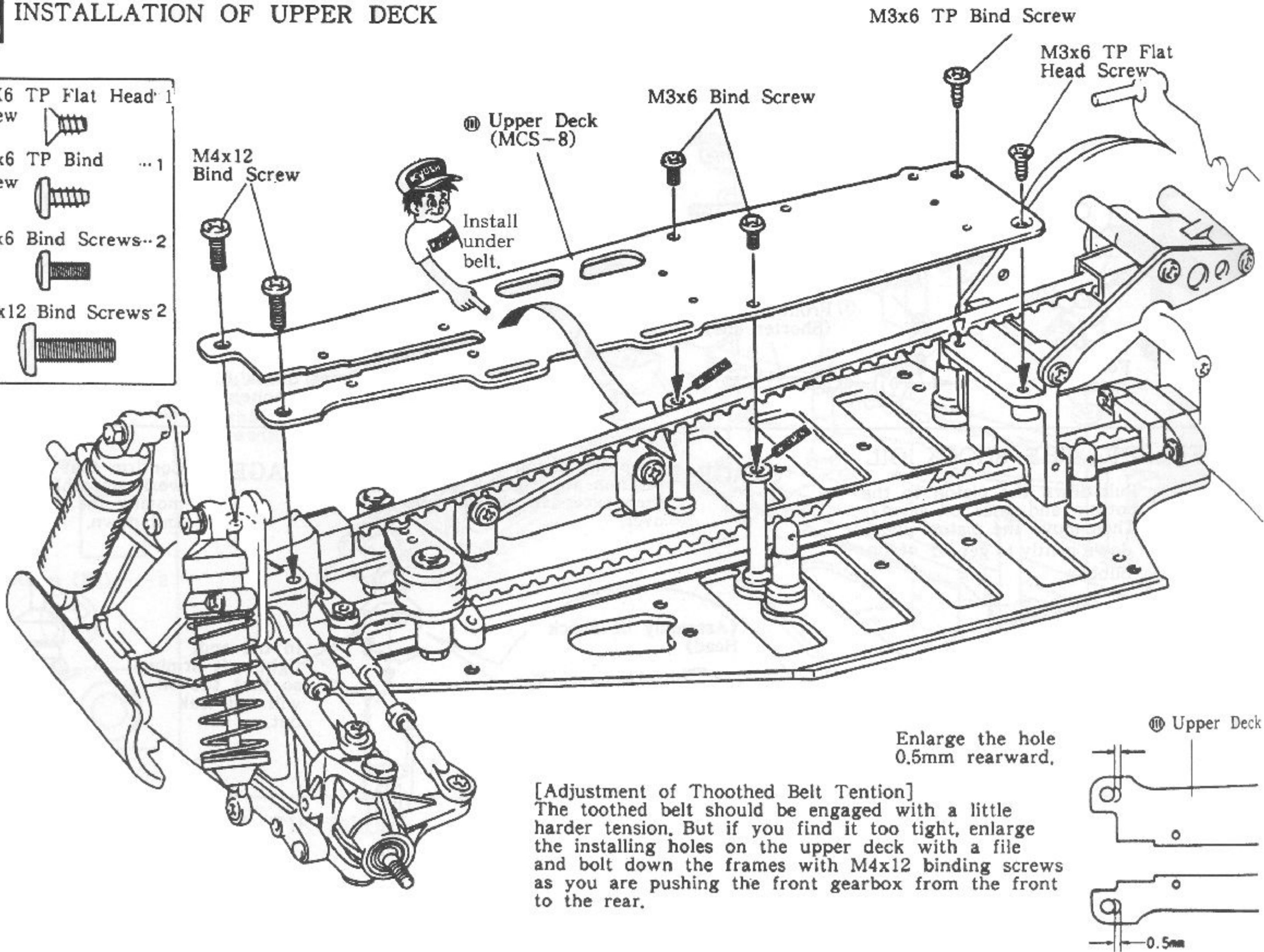





24 INSTALLATION OF BELT COVER (B) • (C)

STAGE 1

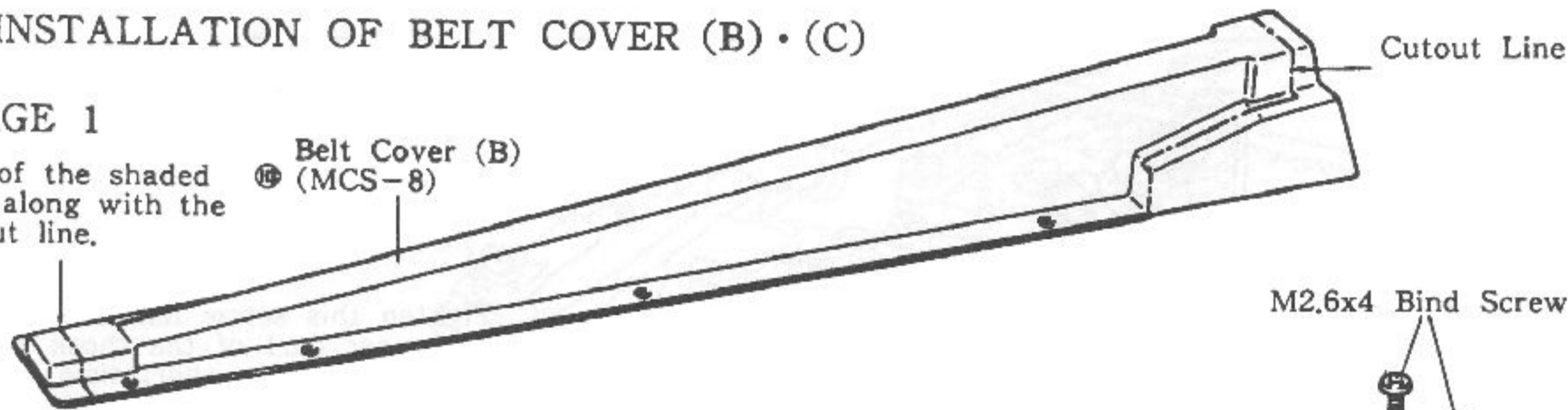
Cut off the shaded area along with the cutout line.

Belt Cover (B) (MCS-8)



- M2.6x4 Bind Screws ... 4 
- M2.6x6 TP Bind Screws ... 4 
- 2.6 φ Washers (Black) ... 4 

After installing the belt cover, apply screw locking compound along the obliquely lined edges (both sides) as done in step 9.

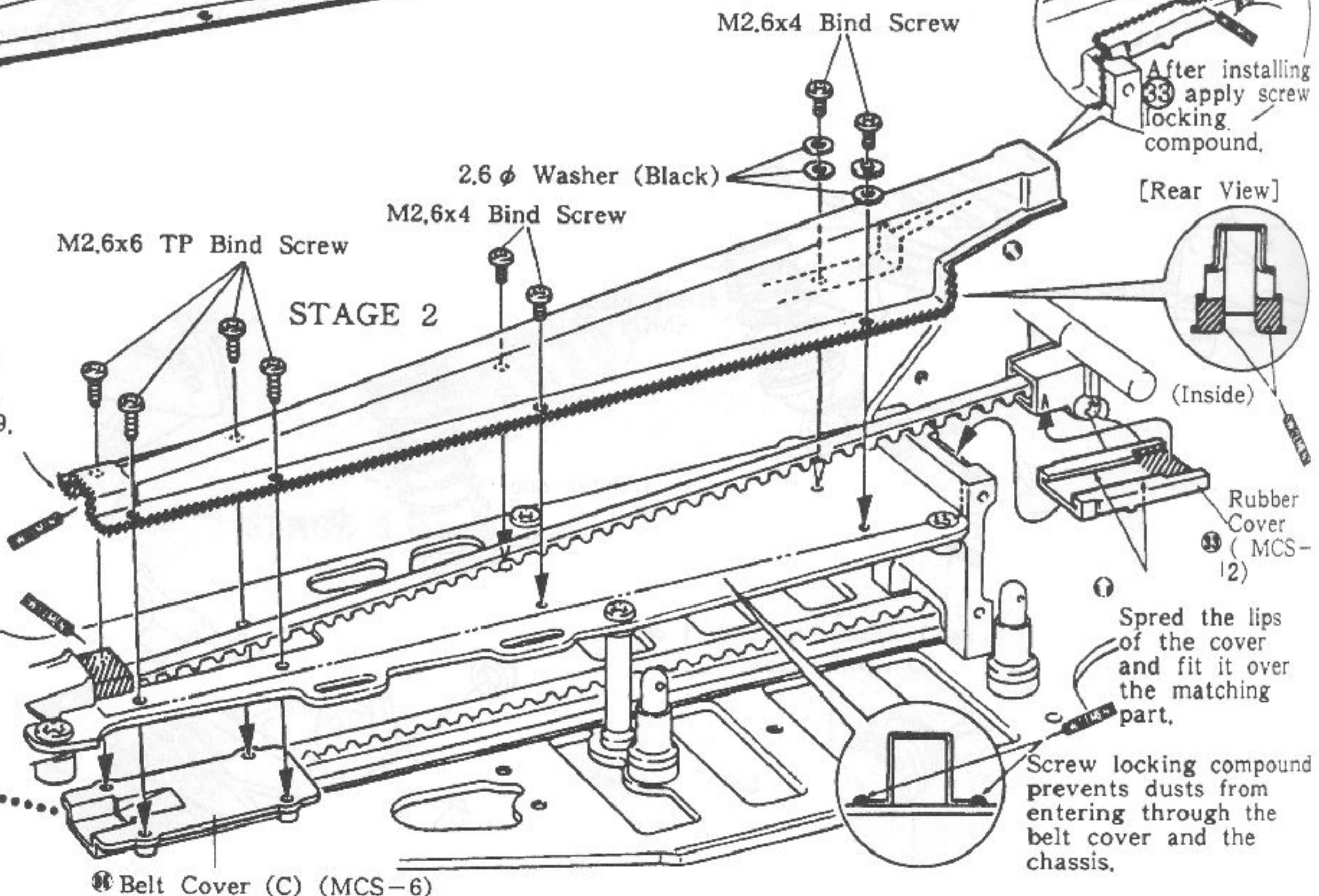
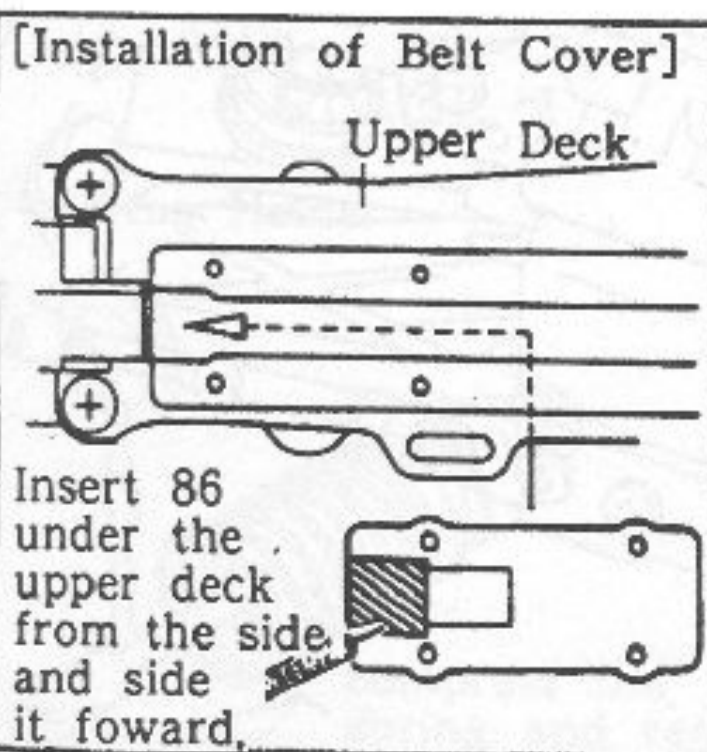

25 CHECKING THE BELT COVER



CAUTION
If the cover is not sealed as described, the gear may be broken by built-up dust.

Dust enter through a gap no matter how small it is, along the seam of the belt cover. The dust may cause such troubles as damaging the belt or the gear teeth or a failure in power transmission. Check again to see if the seam and a thread are filled with locking agent completely.

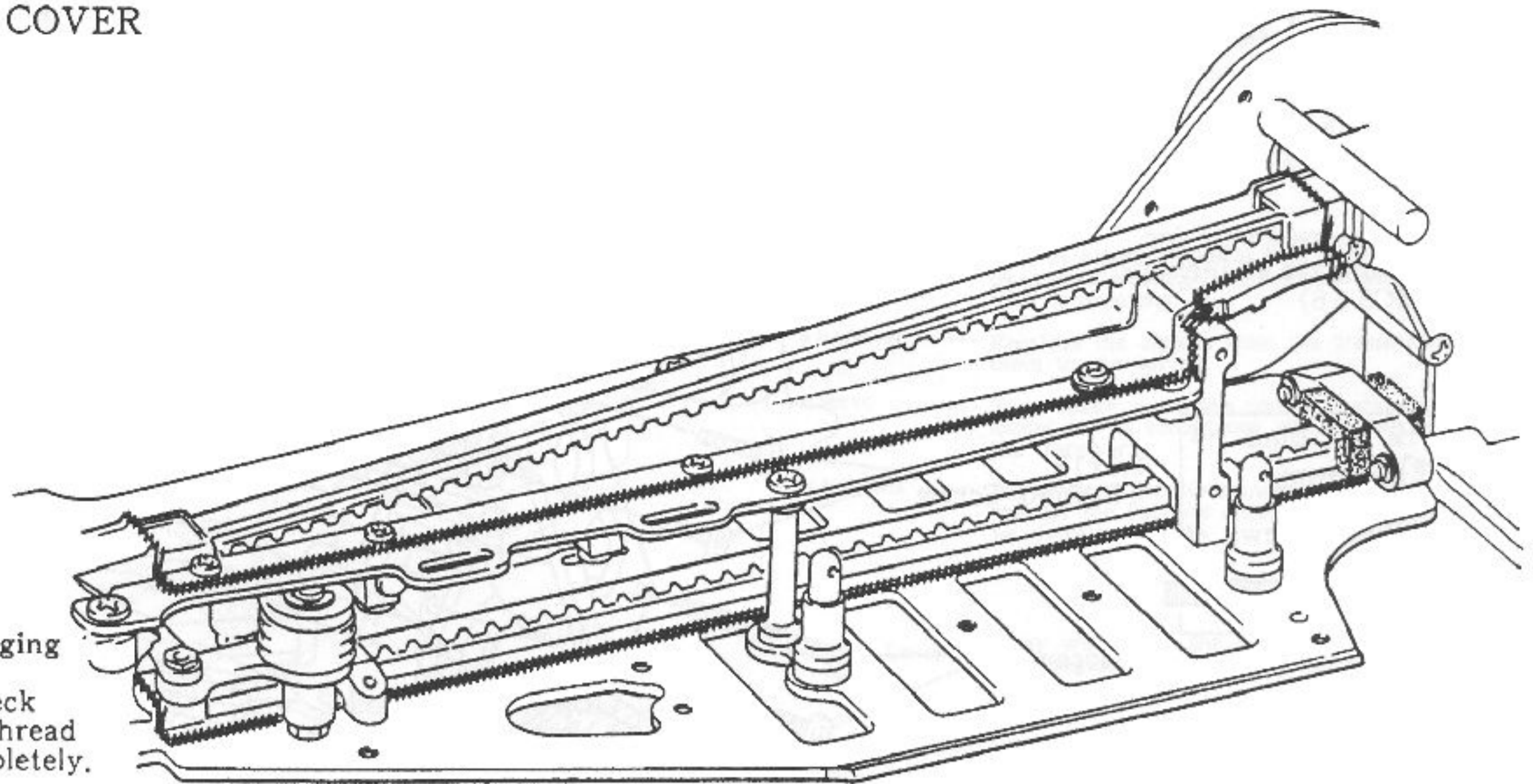

26 INSTALLATION OF MOTOR CORD

(Not included)

- SPA240WS
- Le Mans H240S
- Le Mans Speed 240T
- Le Mans 360GOLD

STAGE 1

⑩ Motor Cord (Red, White) (MCS-8)

⑪ Electronics Condenser (MCS-8)

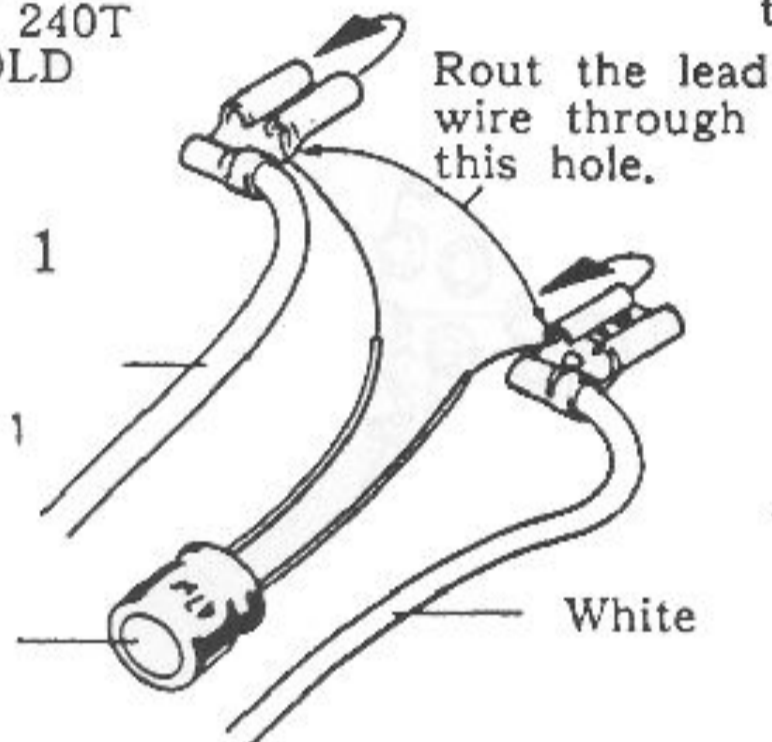

STAGE 2

Solder the red lead to the ⊕ terminal, the white to ⊖

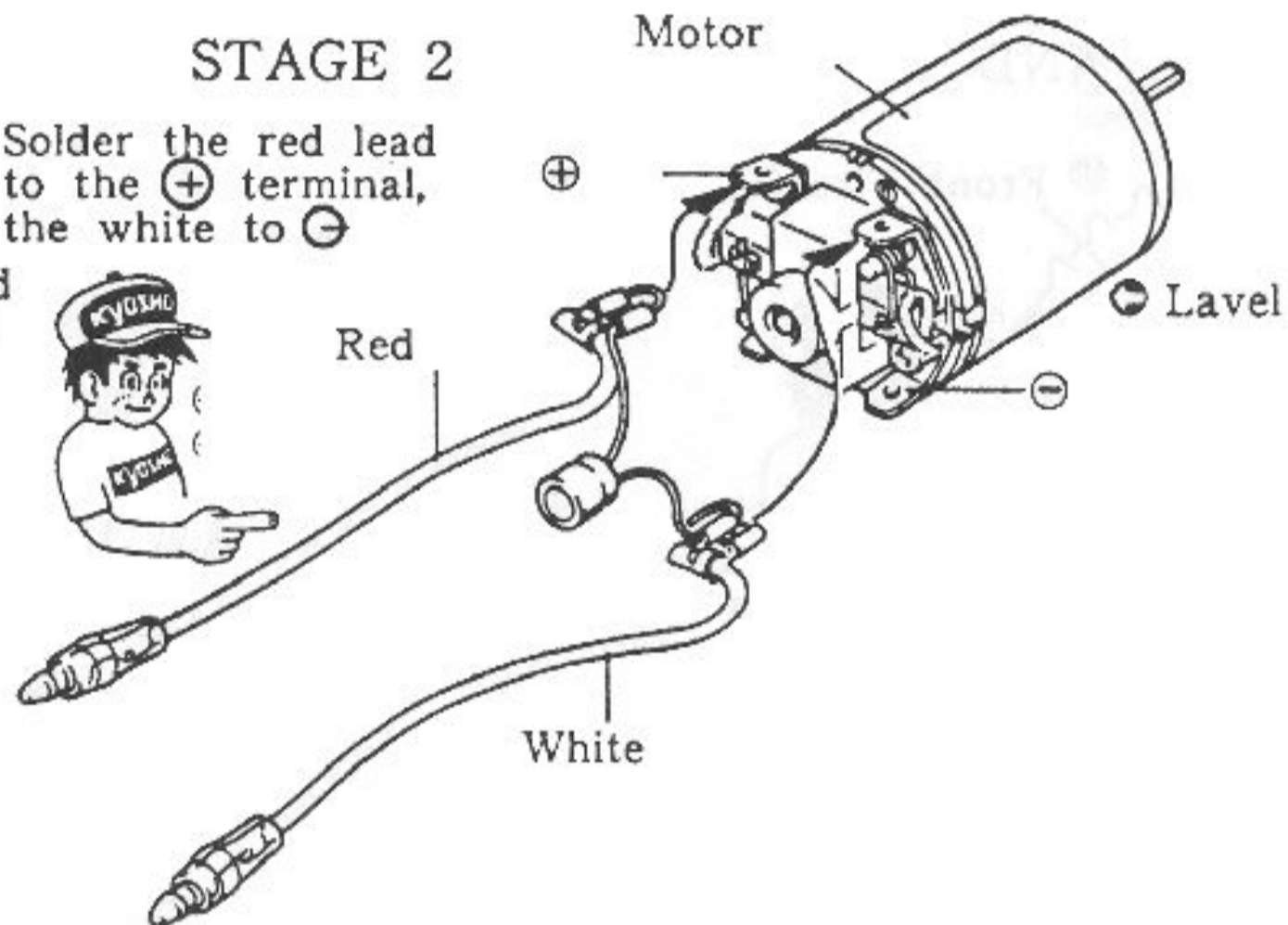

27 INSTALLATION OF MOTOR

STAGE 1

Once remove the upper part of the shock.

⑫ Hex Key (1.5mm) (MCS-1)

M3x3 Set Screw

Set the set screw to the flat on the shaft.

⑬ Motor Plate (MC-5)

M3x10 Bind Screw

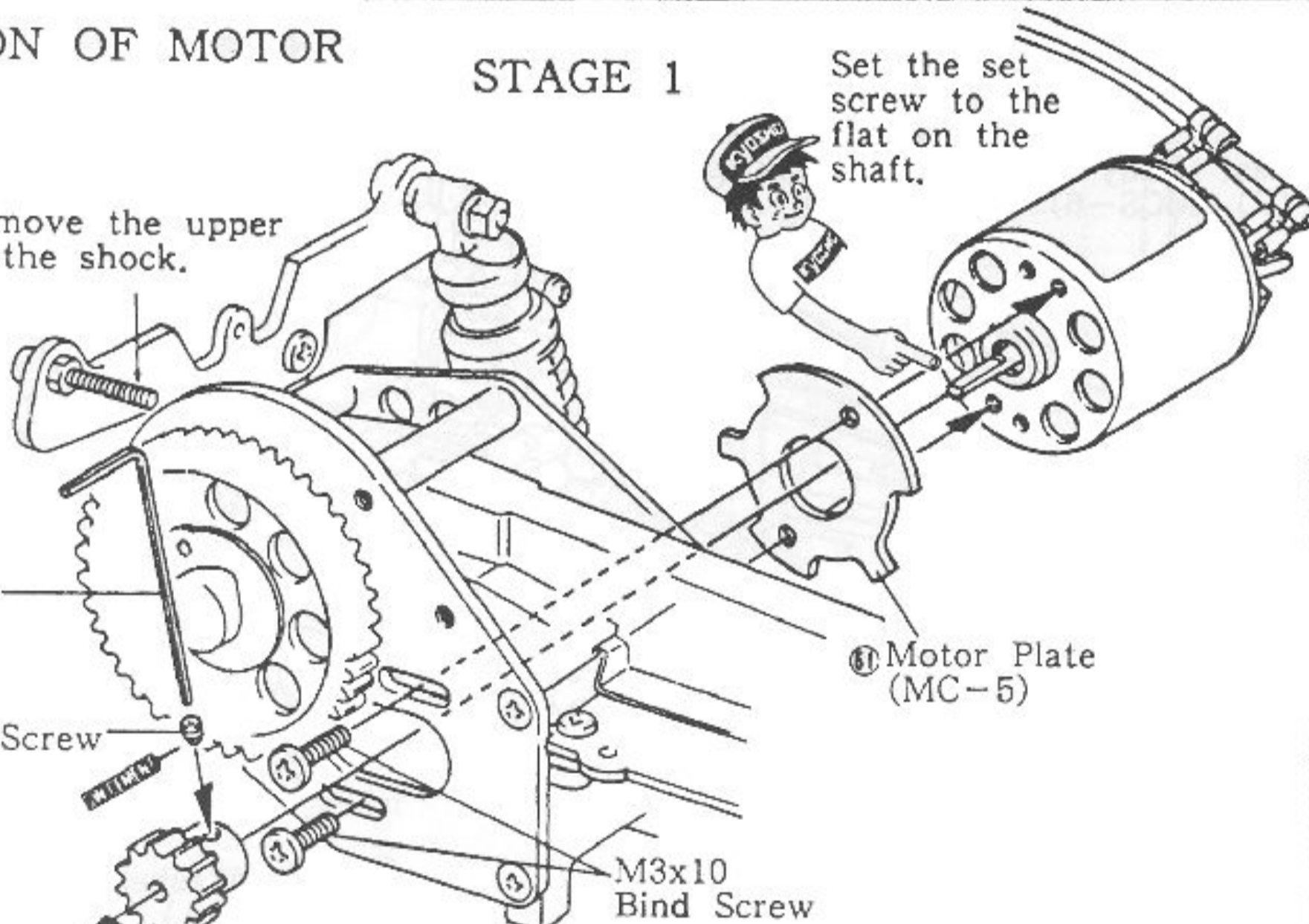

M3x4 Round Head Screws 2

M3x10 Bind Screws 2

M3x3 Set Screws 1

⑭ Pinion Gear (20T) (Blister A)

About 13mm

⑮

⑯

Loosen the two screws marked with ⑮ and move the gear 20 to forward rearward for the adjustment.

Adjustment of Backlash

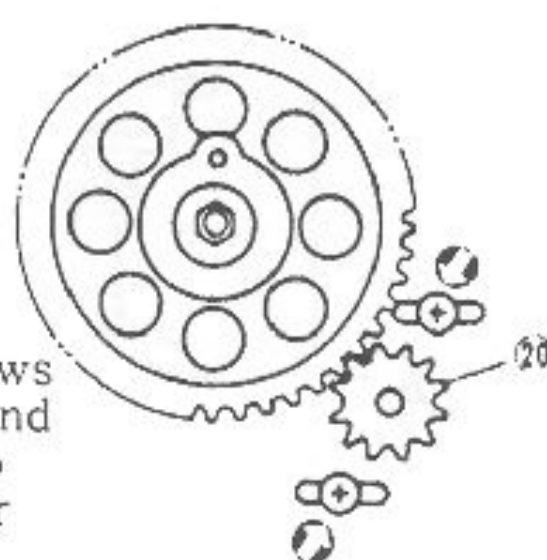

STAGE 2

After installing 114 fix the shock as it was before.

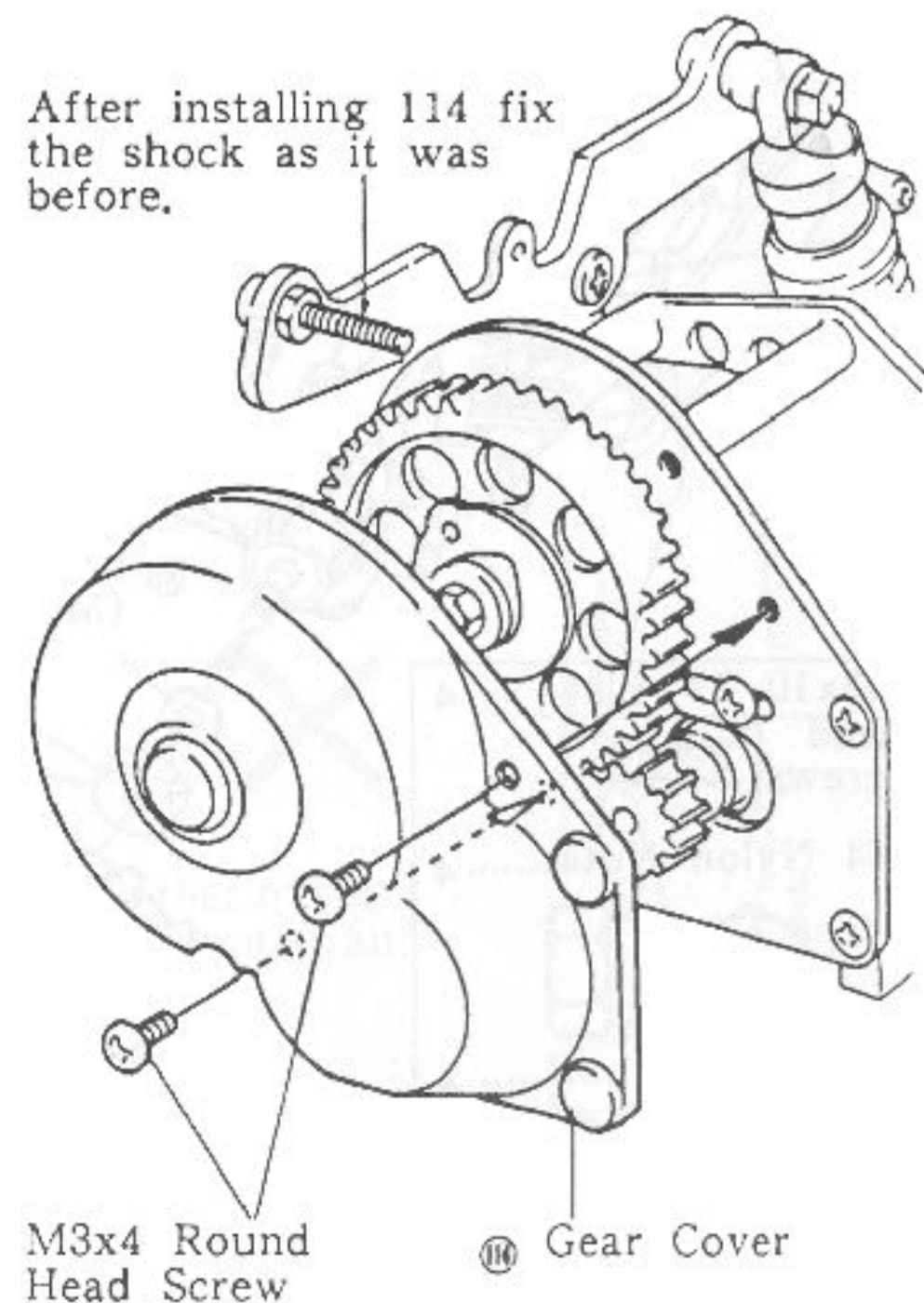

M3x4 Round Head Screw

⑰ Gear Cover

28 INSTALLATION OF WING STAY

*Parts to be used here for assembling are all included in (MCS-6)

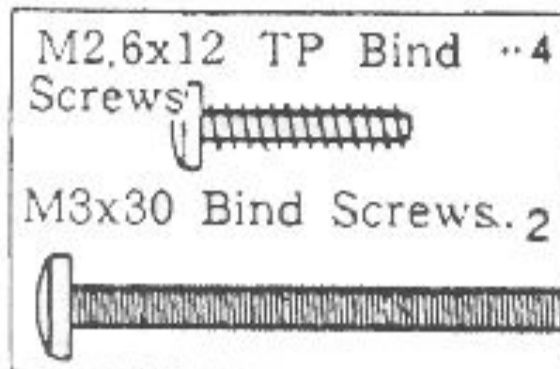

M3x30 Bind Screw

2,6x12 TP Bind Screw

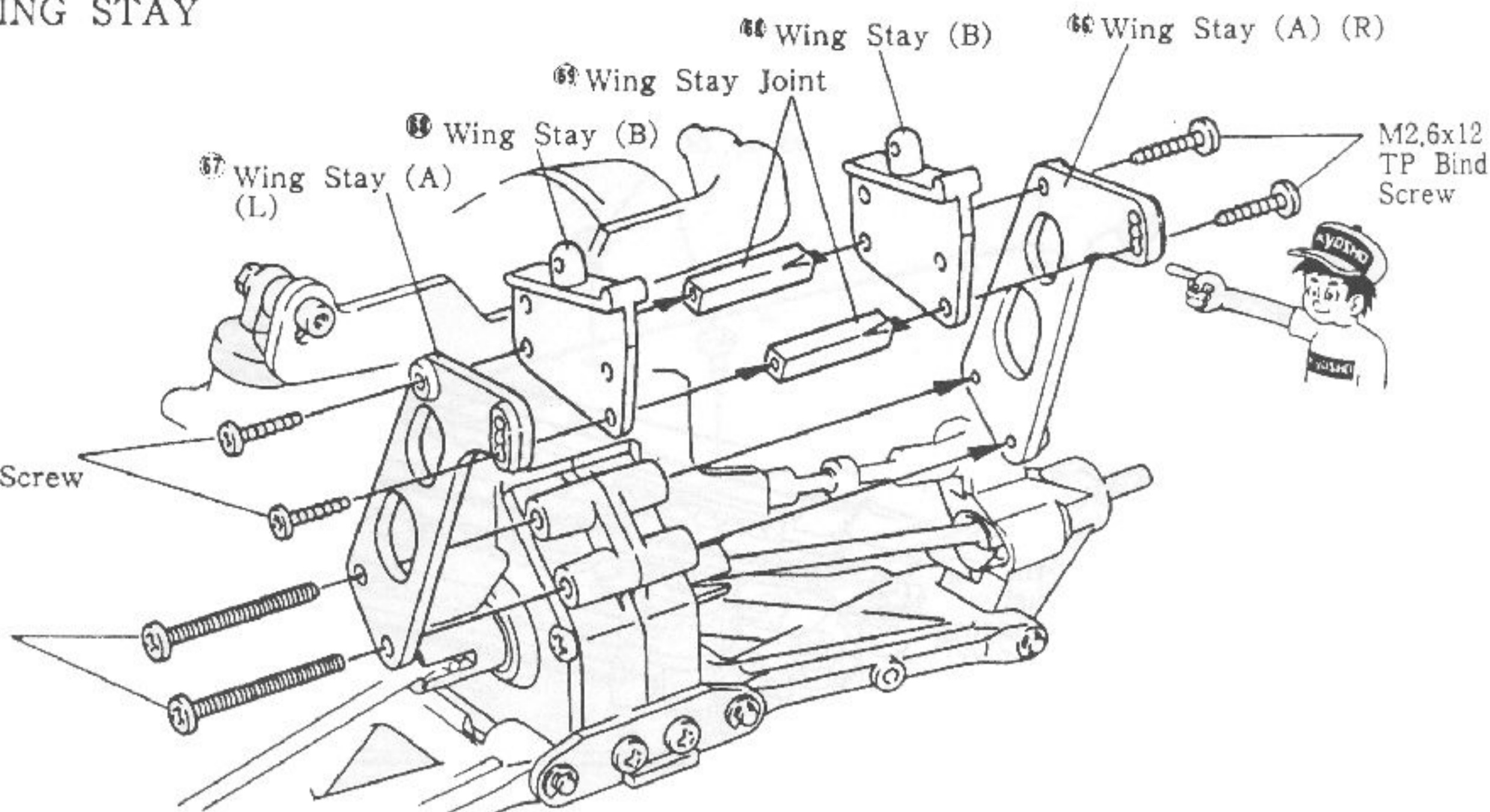

29 ASSEMBLY OF TIRE AND WHEEL

<Front>

Front Wheel (MCS-3)

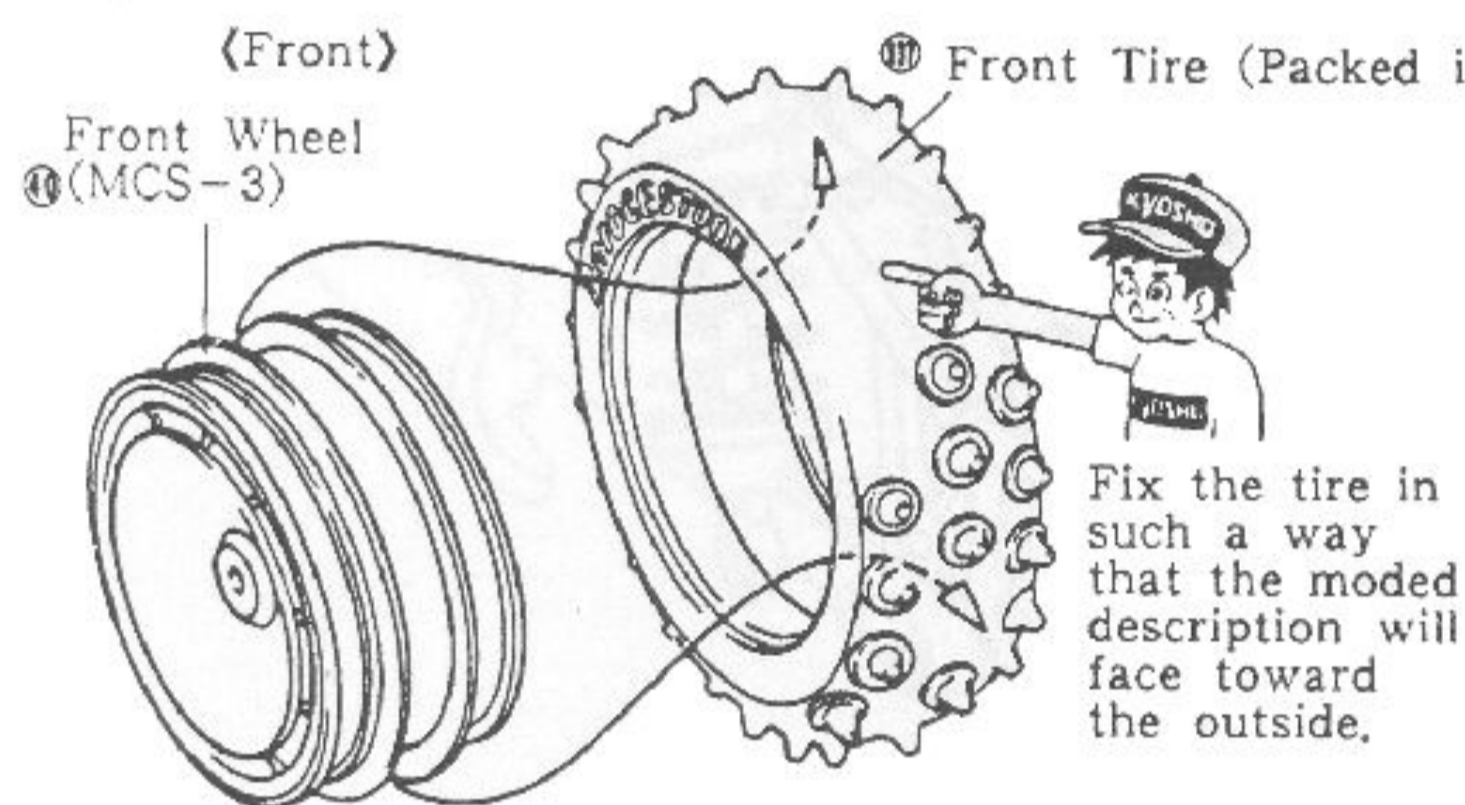

<Rear>

Rear Wheel (MCS-3)

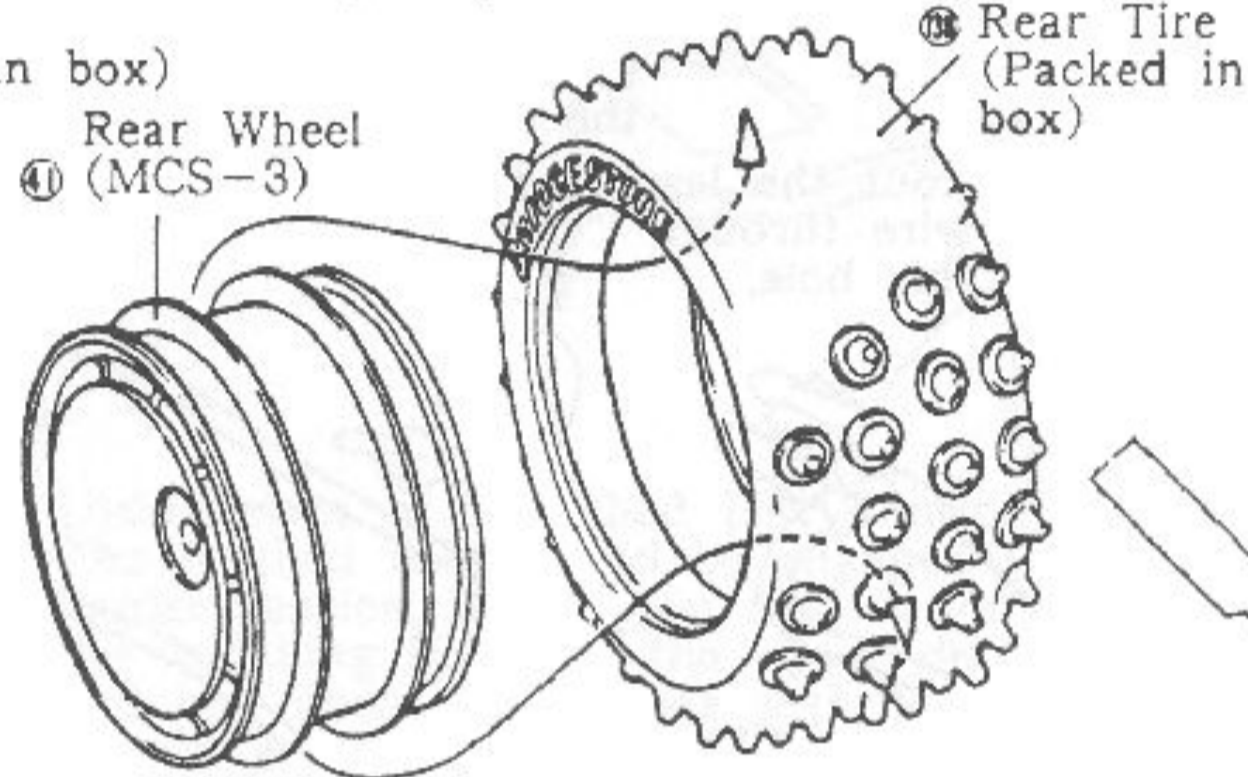

<For Front & Rear>

Check to see if all edges and rims have fitted completely instant glue along the fitting seams.



30 INSTALLATION OF TIRE

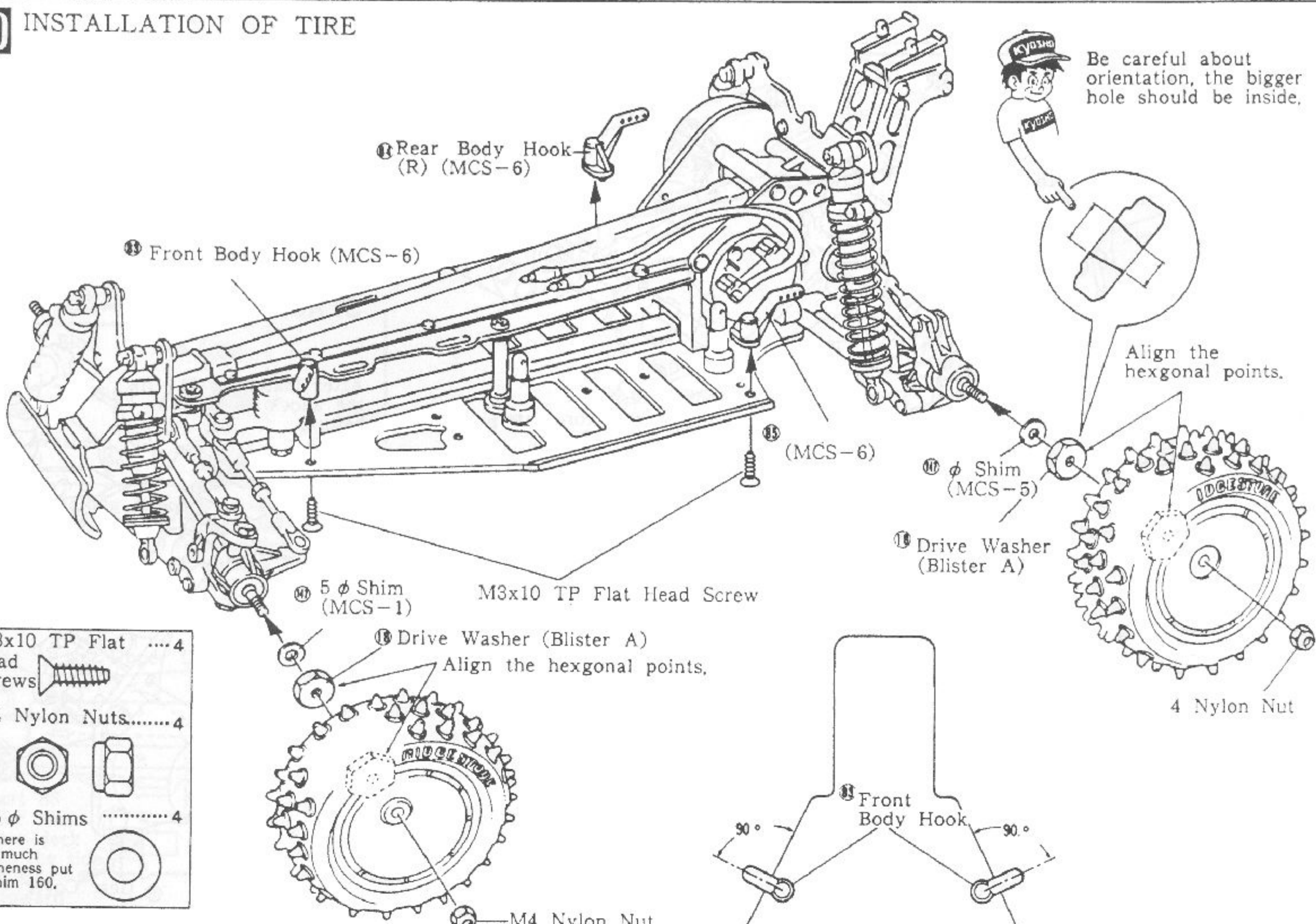

31 HOW TO CHECK RADIO SYSTEM

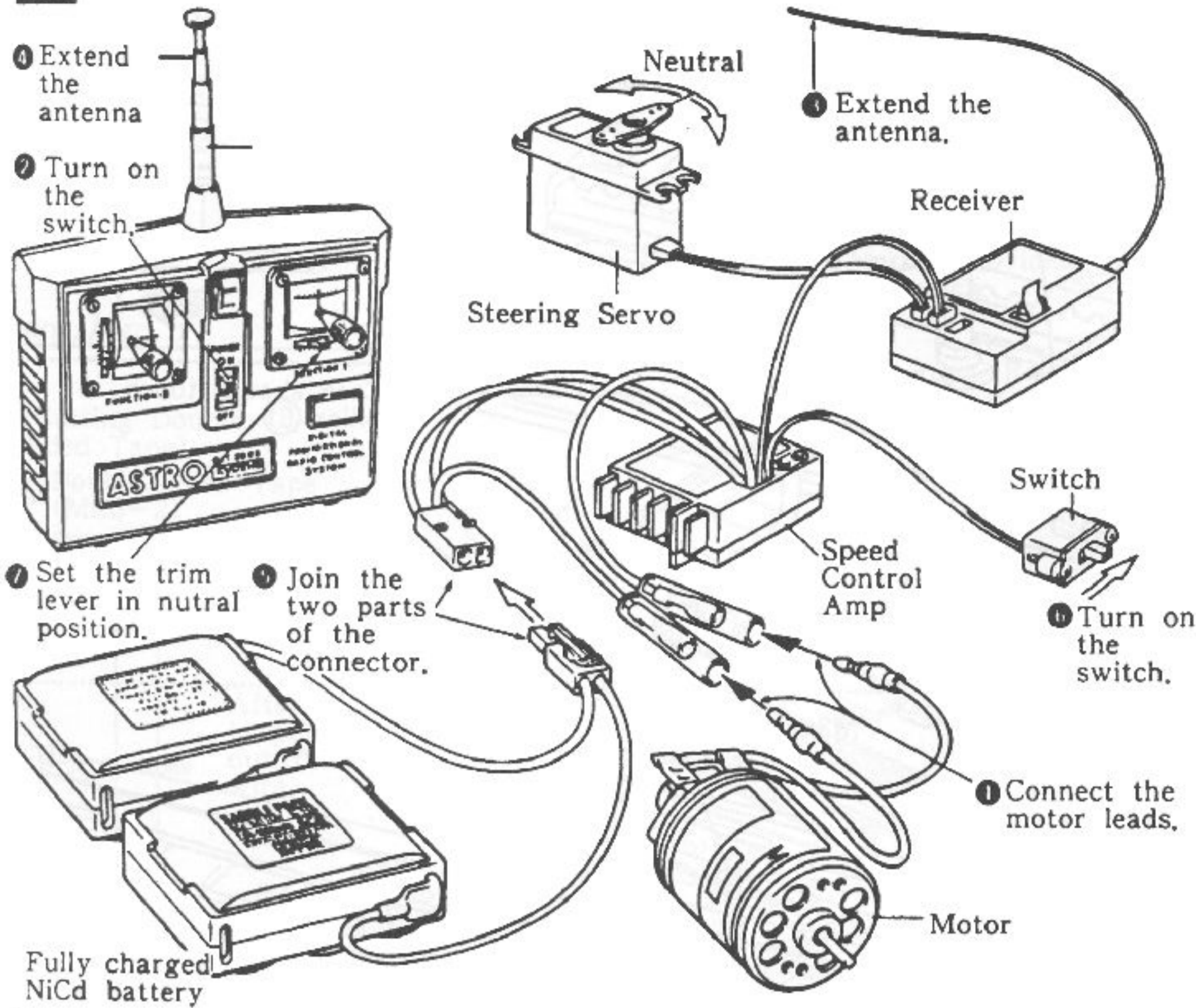

*Operate the radio control units in order of the neumerical figures.
A two channel radio is composed of things like a transmitter, receiver, servos, and battery.

- * Transmitter --- It is in effect a control box. Signal waves are transmitted through an antenna according to the stick movements.
- * Receiver ----- Receives the signals from the transmitter and send them to the servos.
- * Servo ----- They really move the control mechanism of a model car in accordance with the signals from the receiver.
- * Antenna ----- An antenna on the transmitter sends signals, and one on the receiver accepts them. They should be fully extended.
- * Trim Lever --- They will adjust the neutral position of servos, thus regulate the steering and advancing controls finely.
- * Battery ----- You can tell the amount of electricity in a battery and how the signals are emitted.
- * Servo Horns ----- They are intermediate devices on the servos to activate the controls. There are several types in shape. They should be selected depending upon the usage.

When switch on the radio...
Get the switches in order from transmitter to receiver.

When switch off the radio...
In order from receiver to transmitter.

32 INSTALLATION OF STEERING SERVO

STAGE 1

Enlarge this hole so that the Control rod can be fitted easily in the next step.



About 13mm

STAGE 2

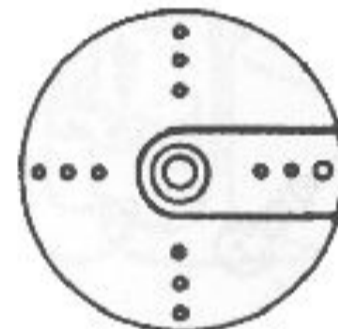

STAGE 3

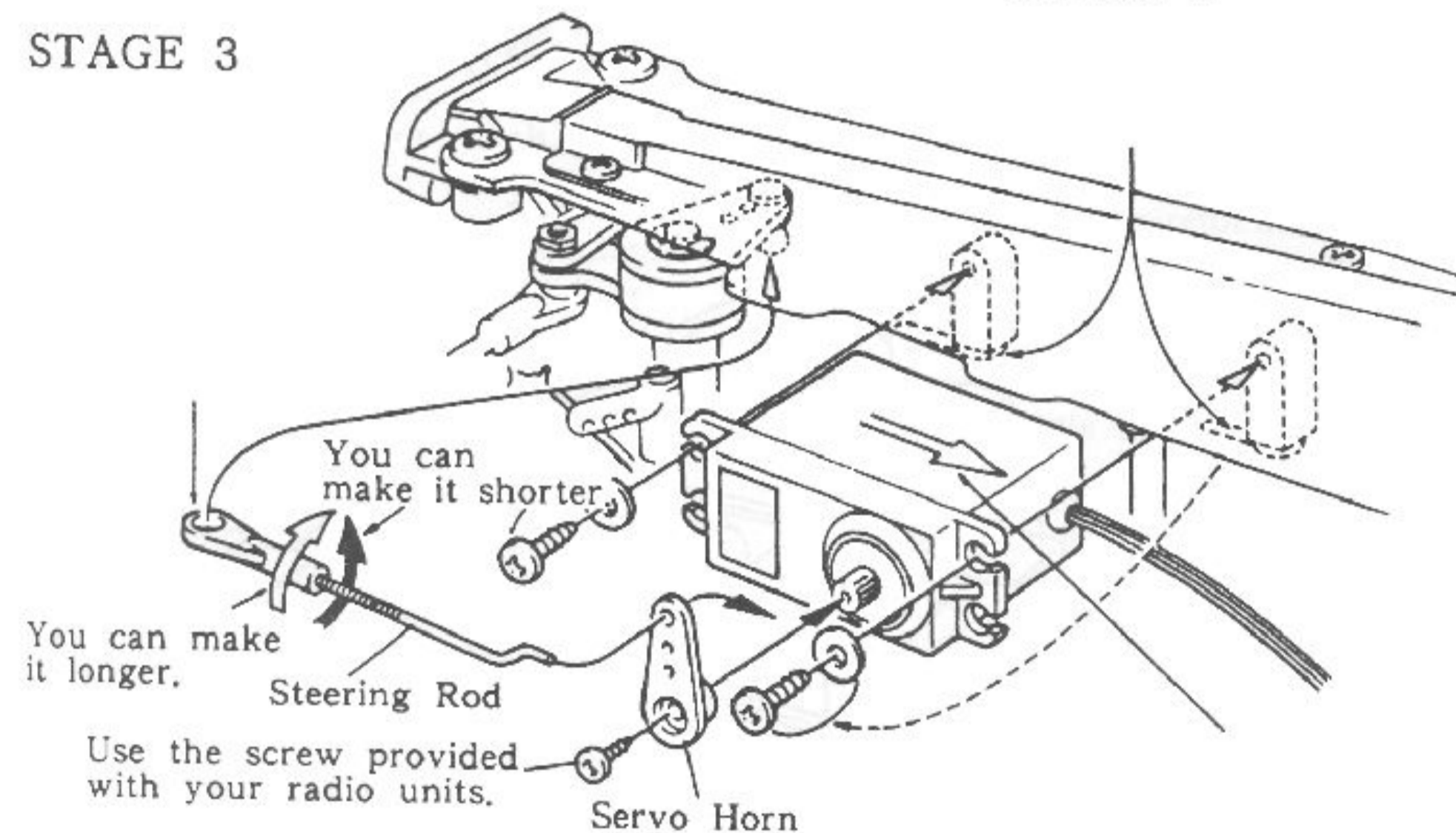

The lines should be aligned in the neutral position.

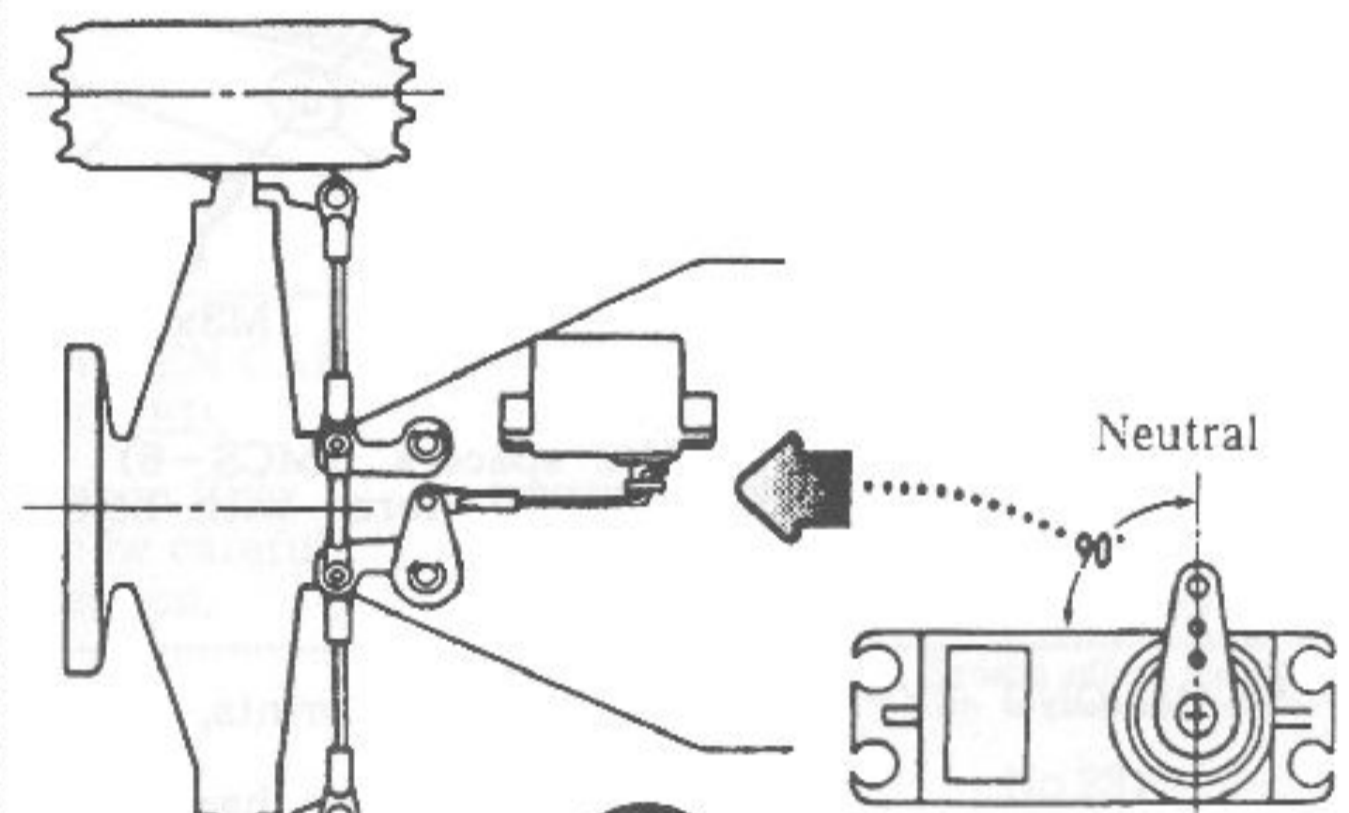

It will hit to the body so bend it like picture below.

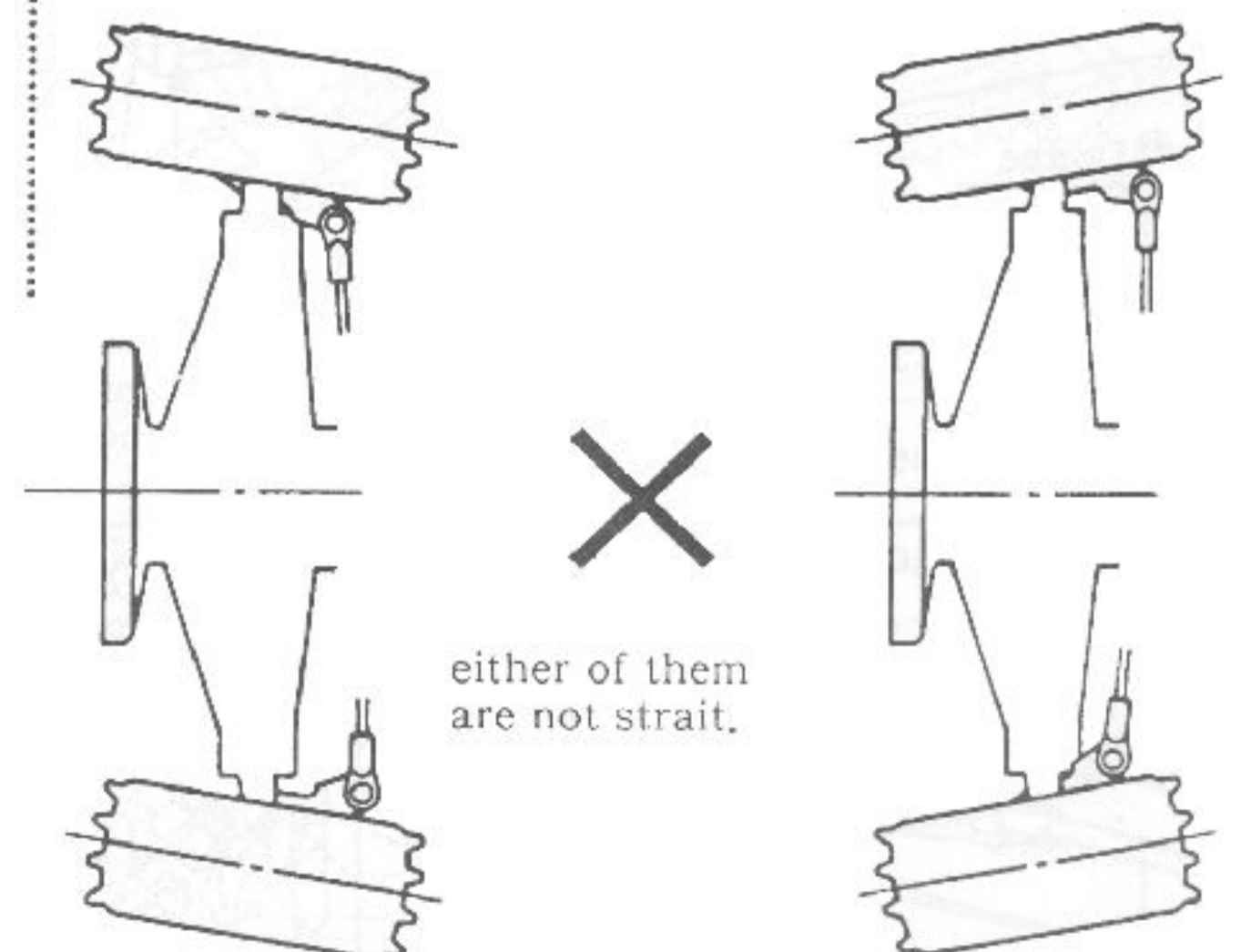
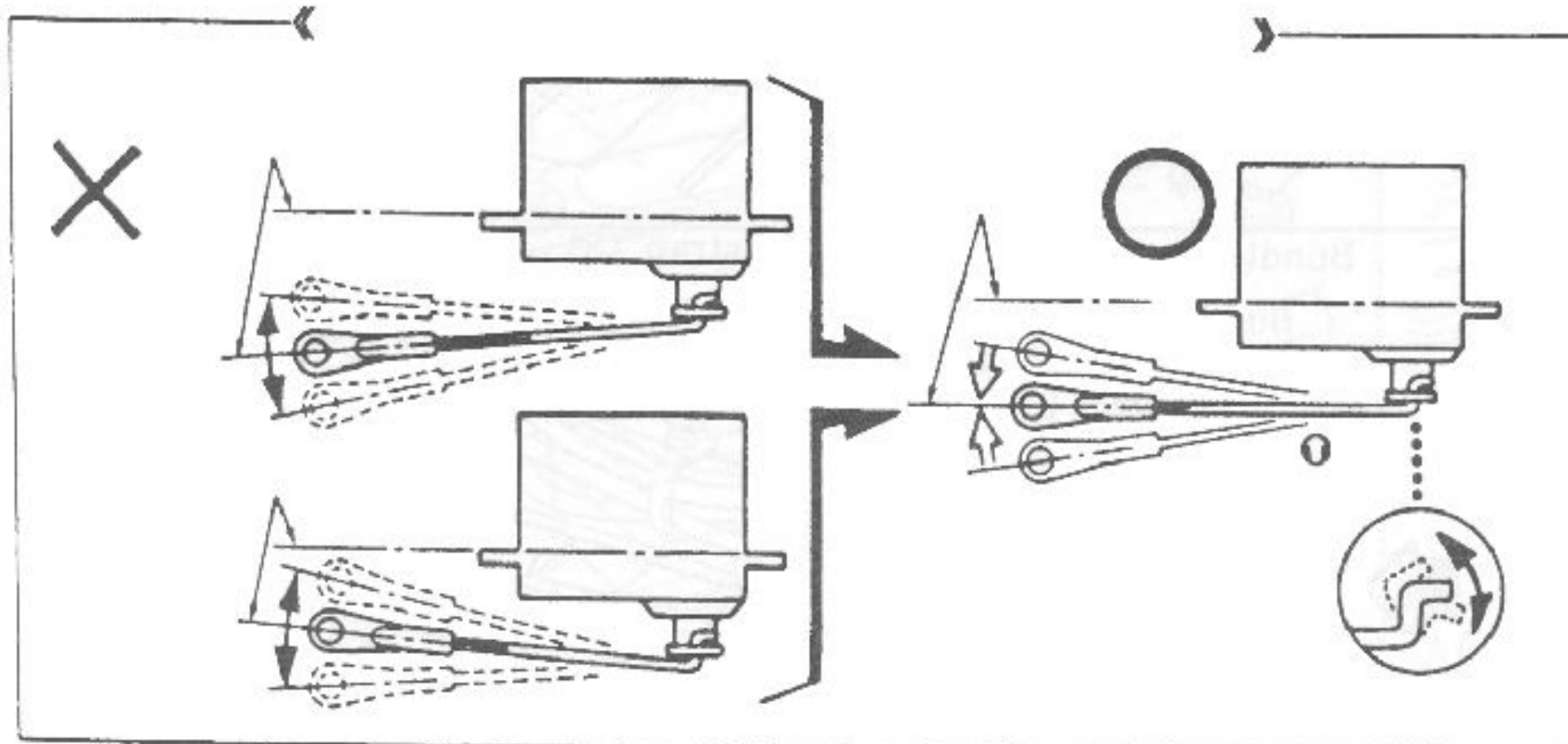

33 INSTALLATION OF ELECTRICAL CONTROLLER

● SMALL TYPE

Mount controller as shown. Be sure that the case does not interfere with the servo horn.

Cut tape to suit width of case.

⑤ Double Sided Tape (TSP-8)

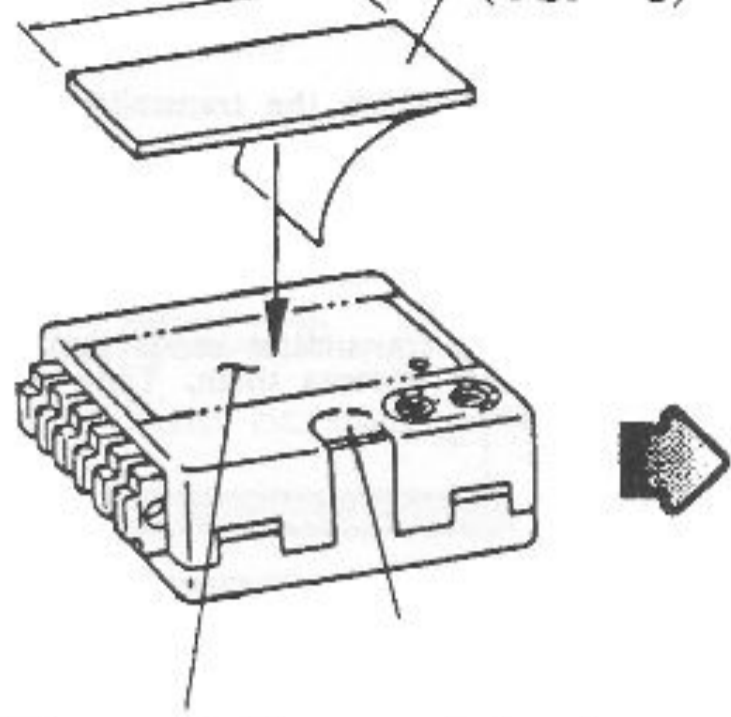

Clean oil, fingerprints, etc., from case.

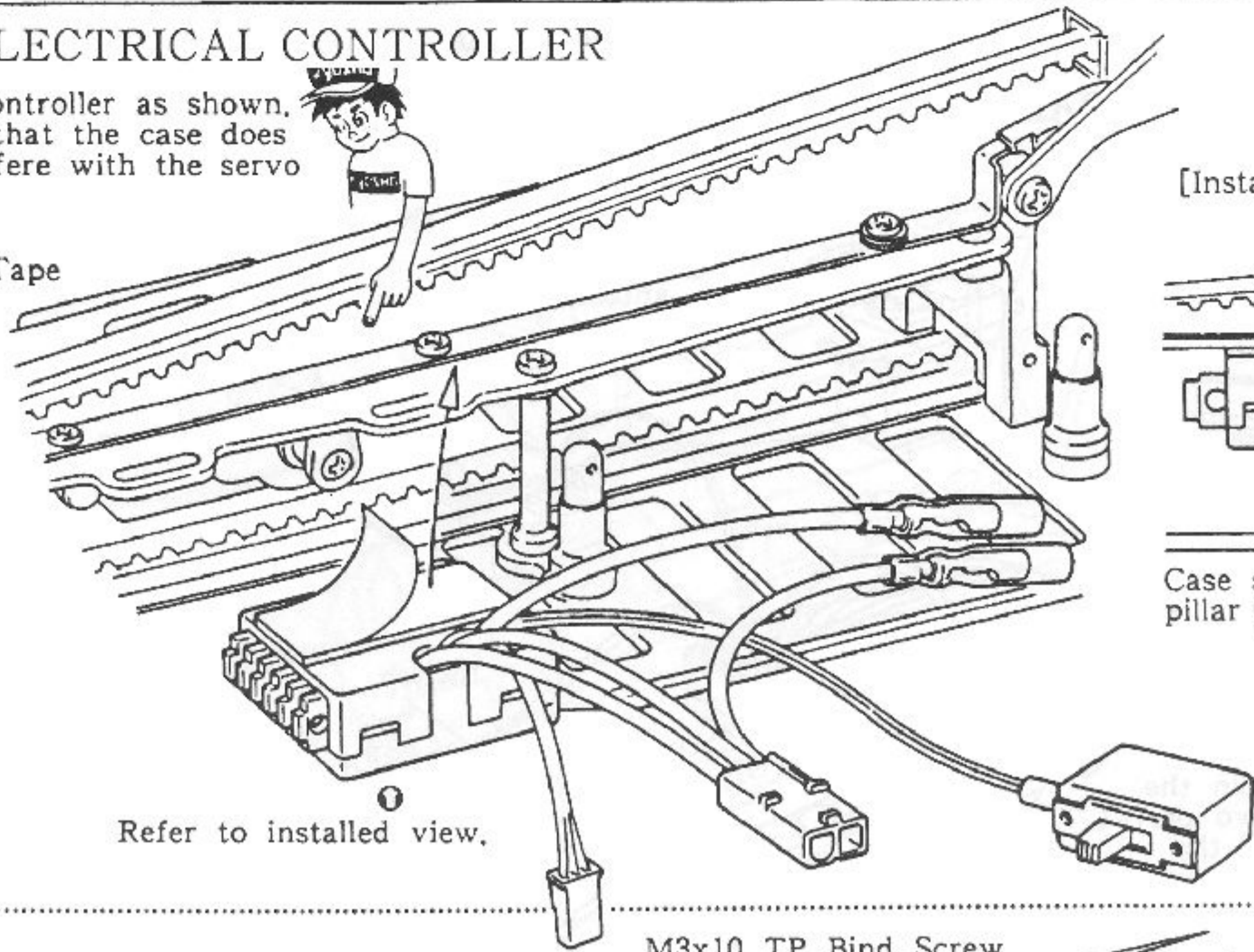

Refer to installed view.

[Installed View]

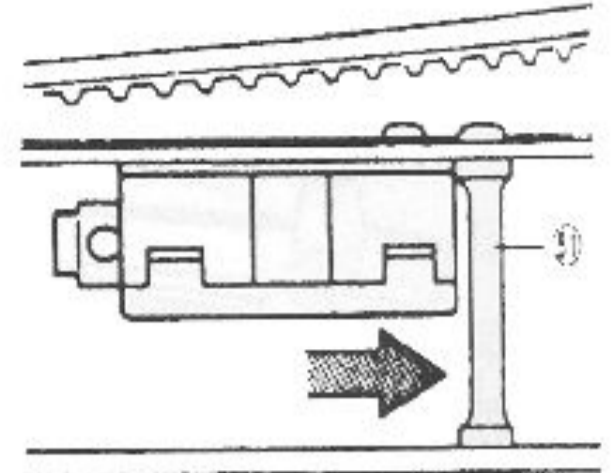

Case should touch pillar ⑤

● SERVO TYPE

⑥ Servo Stay (MCS-6)

Be careful about the orientation.

⑦ Servo Spacer (MCS-6)

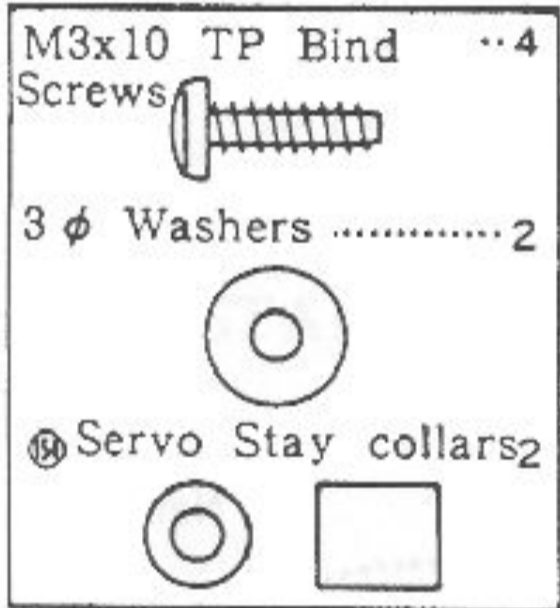

M3x10 TP Bind Screws ... 4

3 φ Washers 2

3 φ Washer

M3x10 TP Bind Screw

⑧ Servo Stay collars 2

Use spacers (MCS-6) if bottom of case interferes with belt.

M3x10 TP Bind Screw

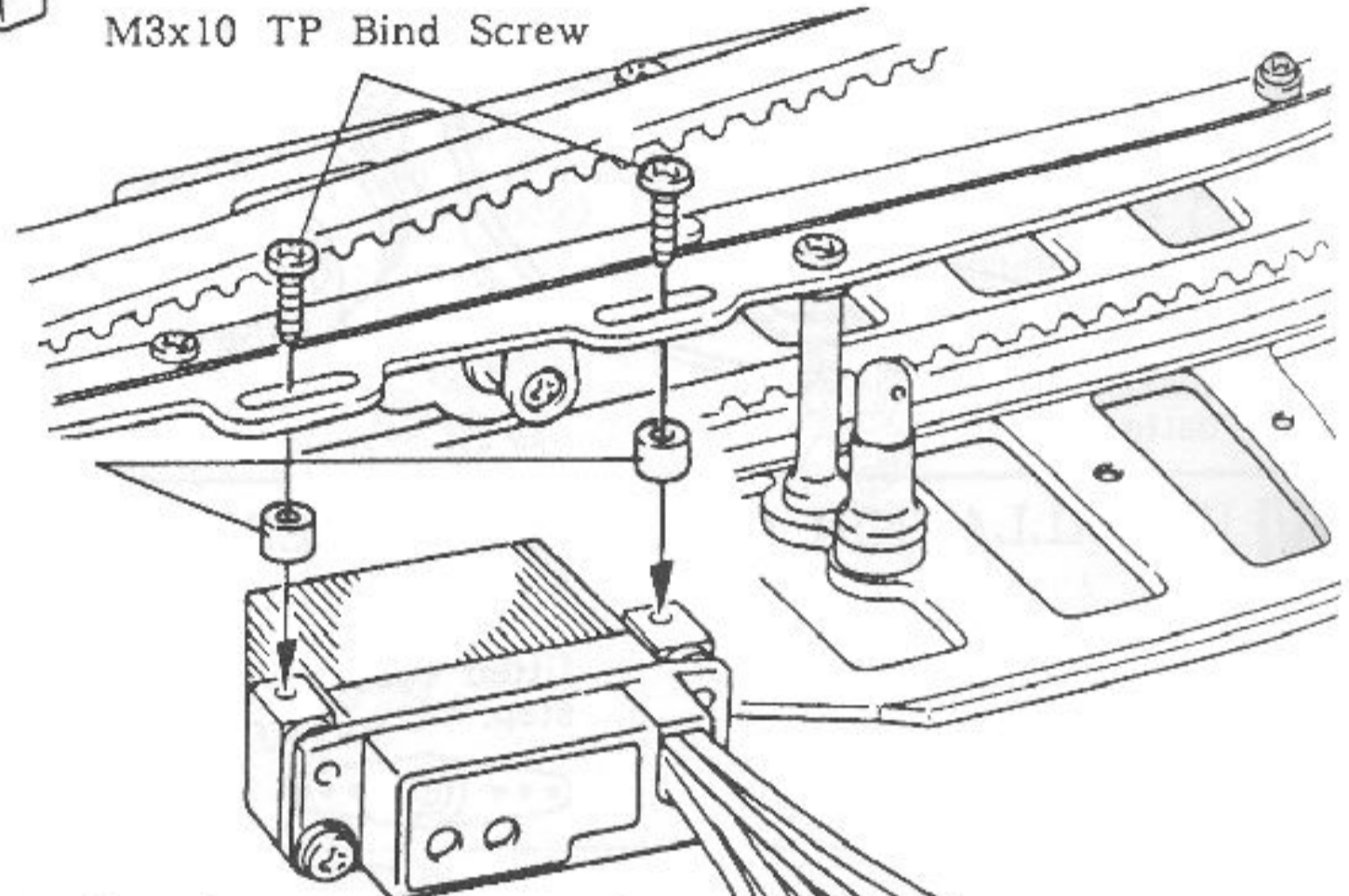
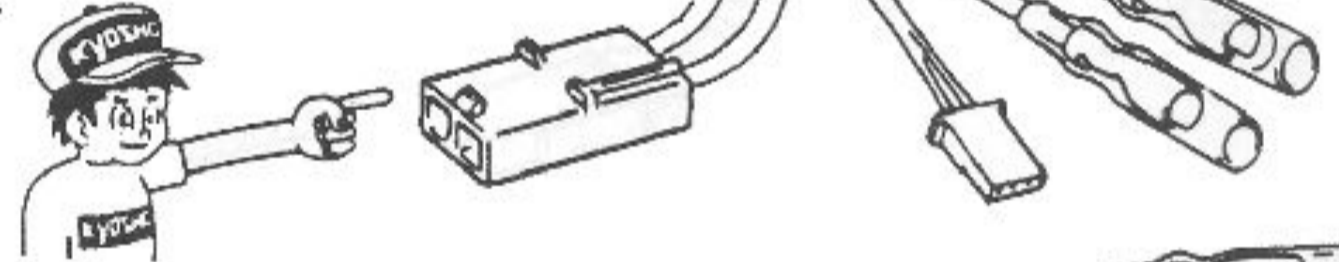

Illustration shows typical connectors. Use a controller suited to your radio set.



● OBLONG TYPE

• Clean oil, fingerprints, etc., from case.

• Double sided tape have to be cut off according to the shape of switch and receiver.

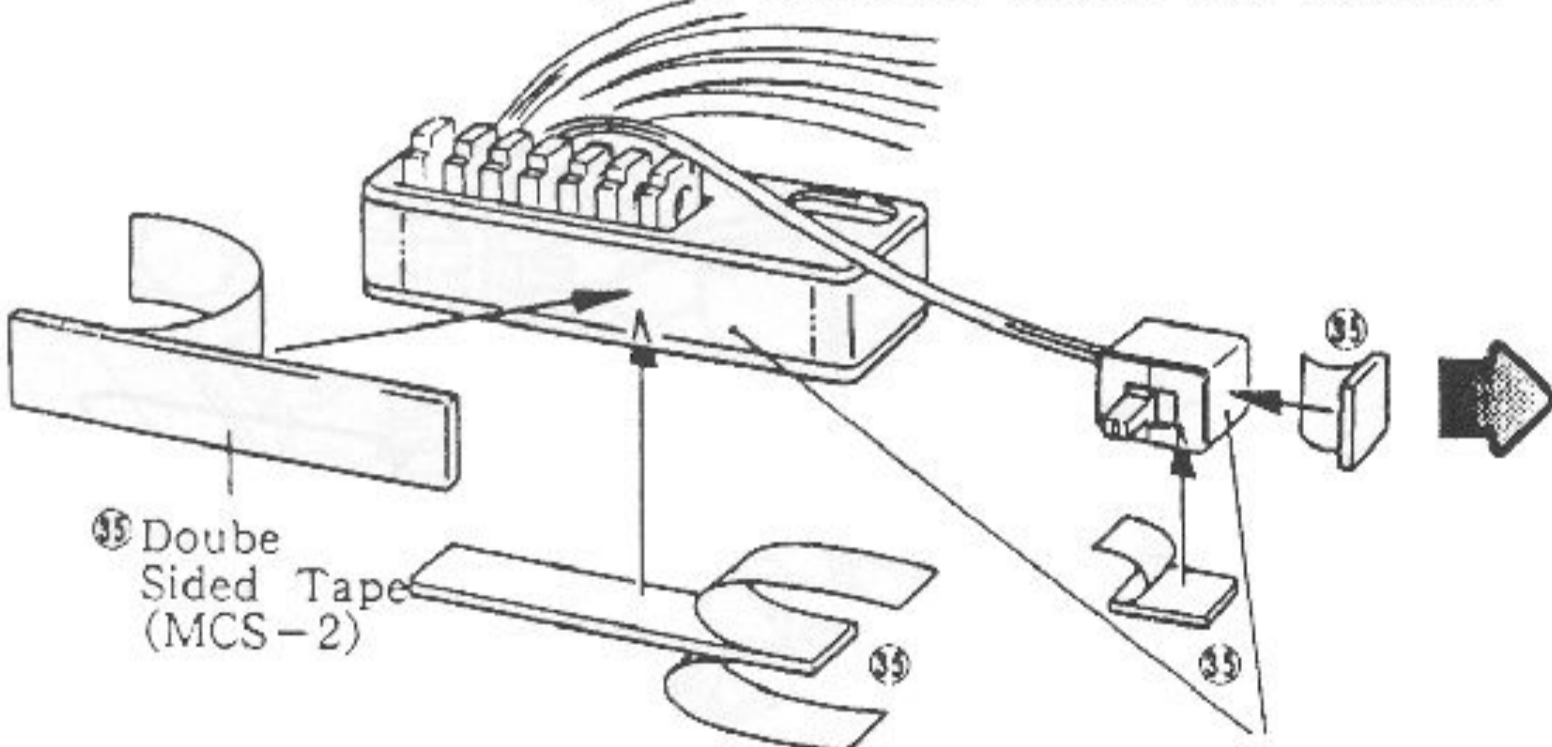

⑨ Double Sided Tape (MCS-2)

Avoid cording side when you apply the tape.

[After Installment of Receiver]

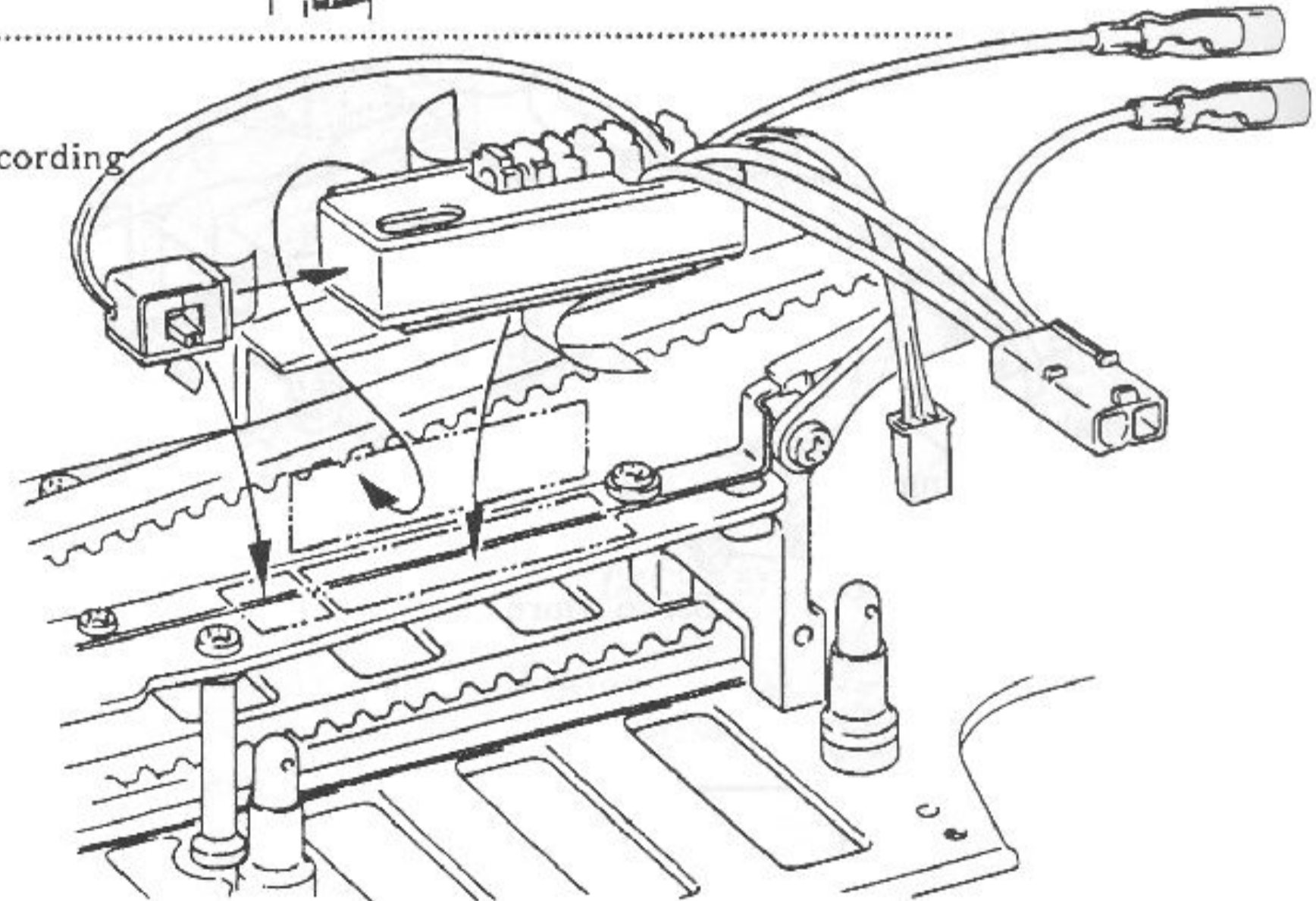

connect the motor connector.

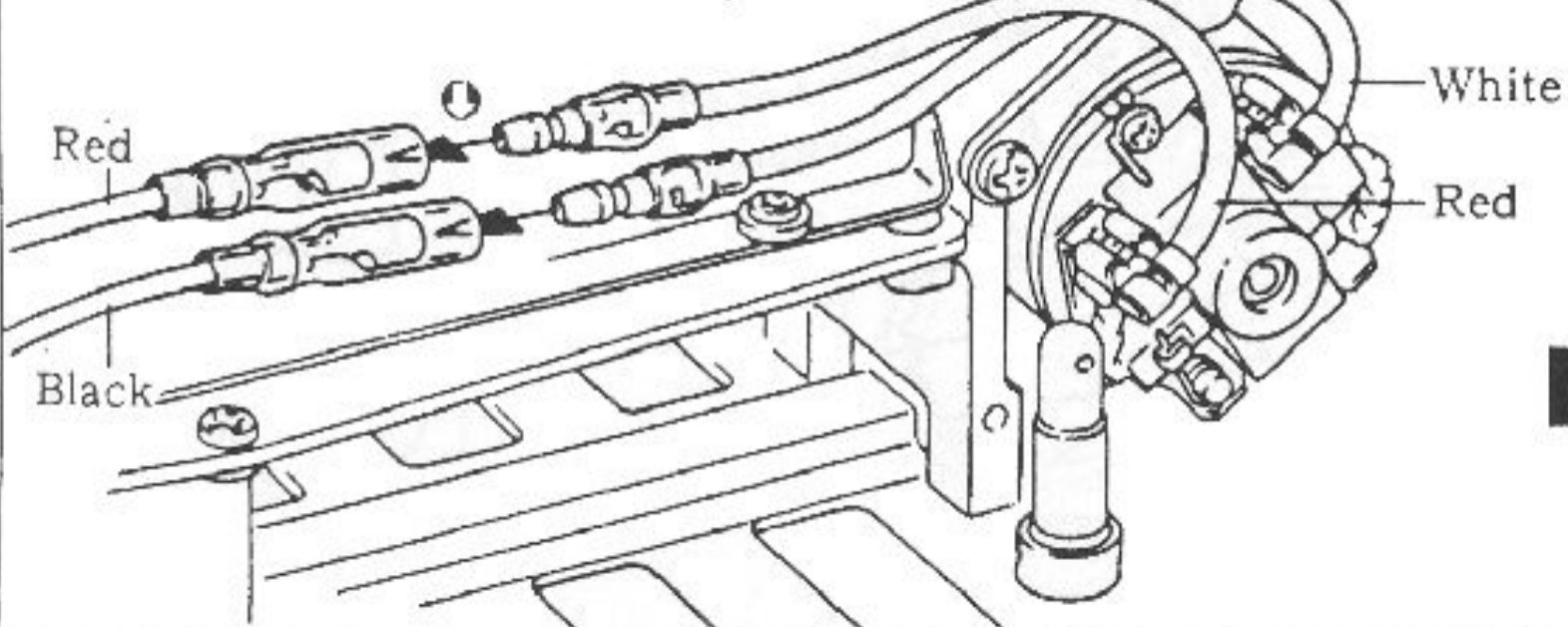

Bundle the cord together with strap (S)

Bundle wires with strap and cut off the excess strap.

⑩ Strap (S) (MCS-2)

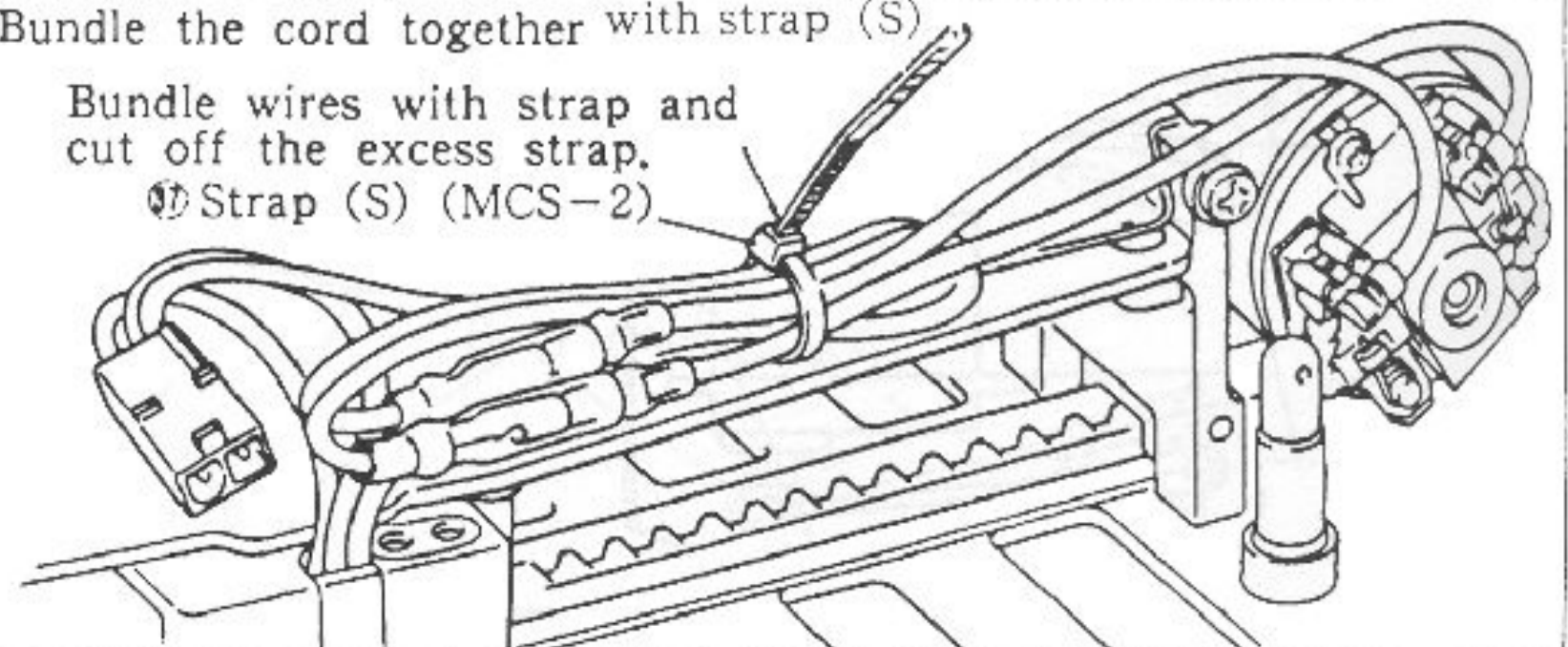

34 INSTALLATION OF SWITCH AND RECEIVER

STAGE 1

M2,6x6 TP Bind Screws ... 2

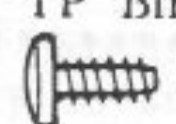

(In case of Electric speed Controller (w/switch))

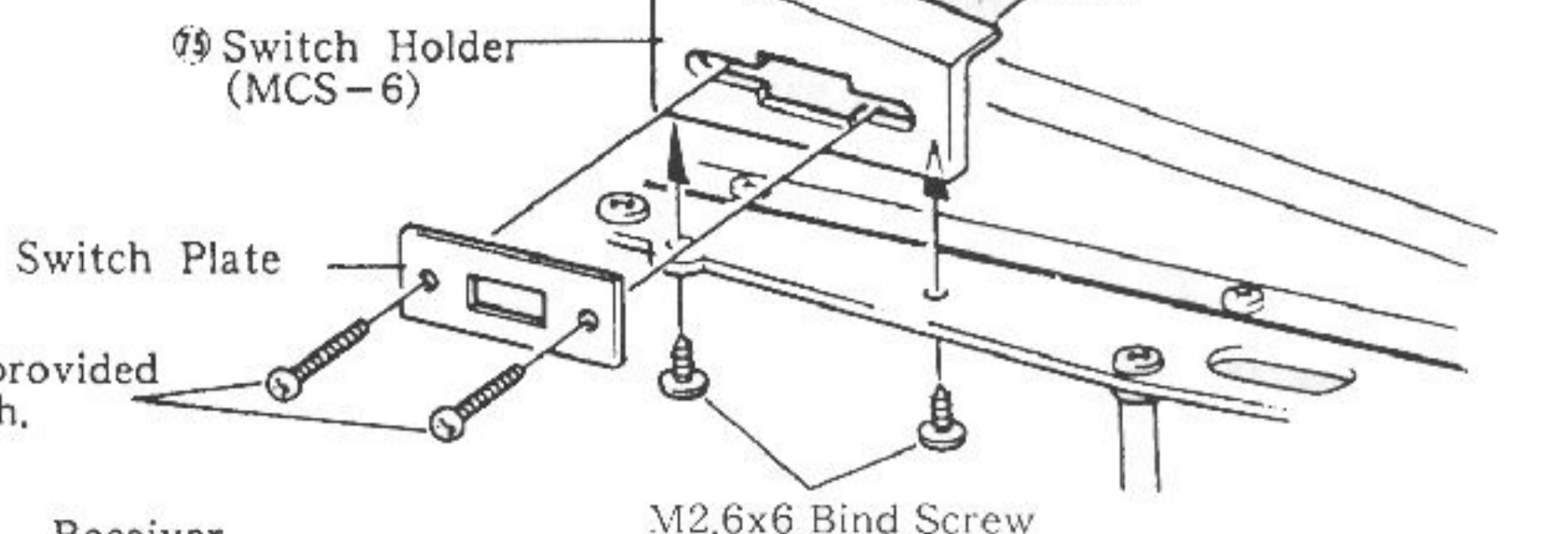

STAGE 2

[Cutting Double Sided Tape]

35 Double Sided Tape (MCS-2)

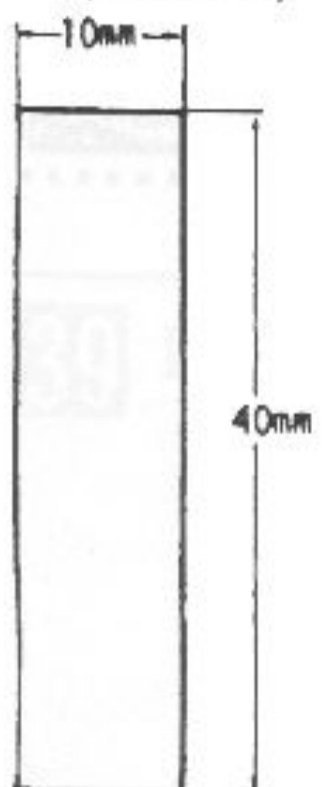

After fixing 119 in position Pull out the antenna wire.

119 Antenna Pipe (MCS-8)

(Actual Size) 2 pcs.

Pass the antenna through the pipe.

STAGE 3

Receiver

Plug in the connector.

Clean the under-side of the receiver and the shaded portion and affix 35.

STAGE 4

37 Strap (S) (MCS-2)

Fasten firmly and cut off the excessive part at this point.

35 INSTALLATION OF BATTERY

REMOVE THE NiCd BATTERY PACK WHEN CAR IS NOT IN OPERATION OR BEING STORED.

The chassis of this model is made of carbon fiber and electricity will flow through. Please be careful for wire short circuit and battery connection.

KYOSHO



No.2331

Kyosho offers 7.2V-1200SCR and 7.2V-1700SCE Saddle Pack as experienced driver. (Incl. Hard battery case)

(Servo Type)

- 7.2V-1200SCR Saddle Pack
- 6.2V-1700SCE Saddle Pack

(Stick Type)

- 7.2V Sprint Battery SCR
- 7.2V Racing Battery

KYOSHO

- Select a high performance NiCd battery pack which is powerful enough to drive a model buggy car vigorously. Kyosho offers the 7.2V Sprint Battery SCR which is prepared for the buggy car specially.

No.2310

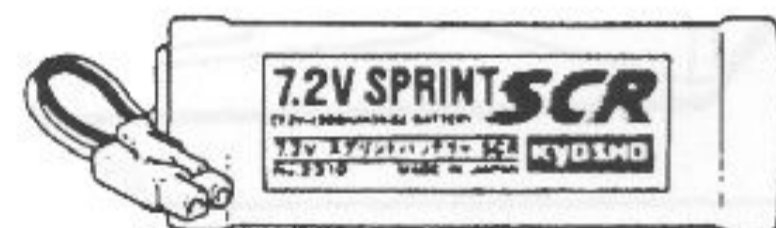

119 Battery Stopper (MCS-6)

119 Hook Pin (MCS-1)

119 NiCd Strap (MCS-8)

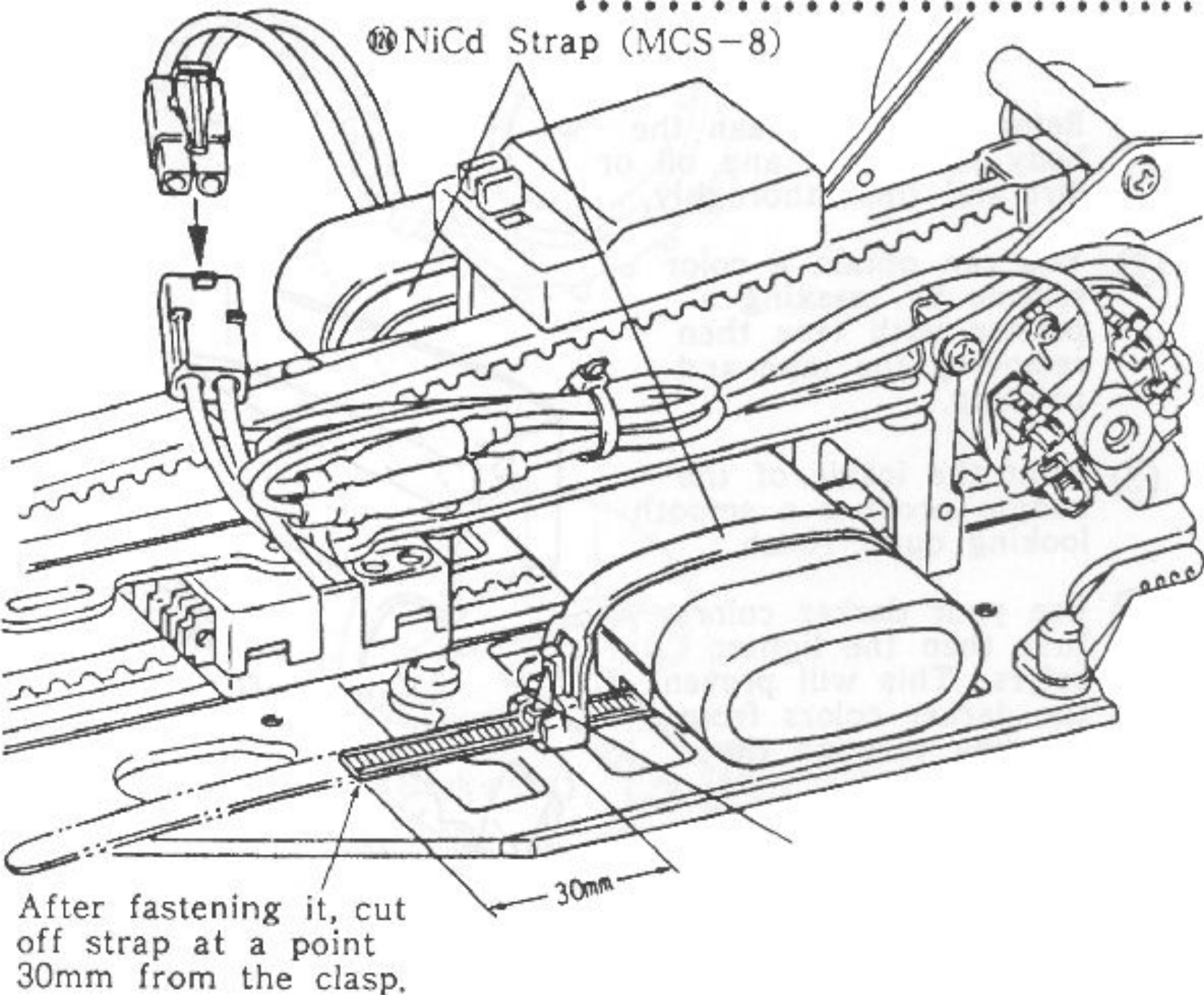

36 CUTTING OUT BODY, UNDER COWL AND WING

Cut off shaded area.

Finish the cut line with sander.

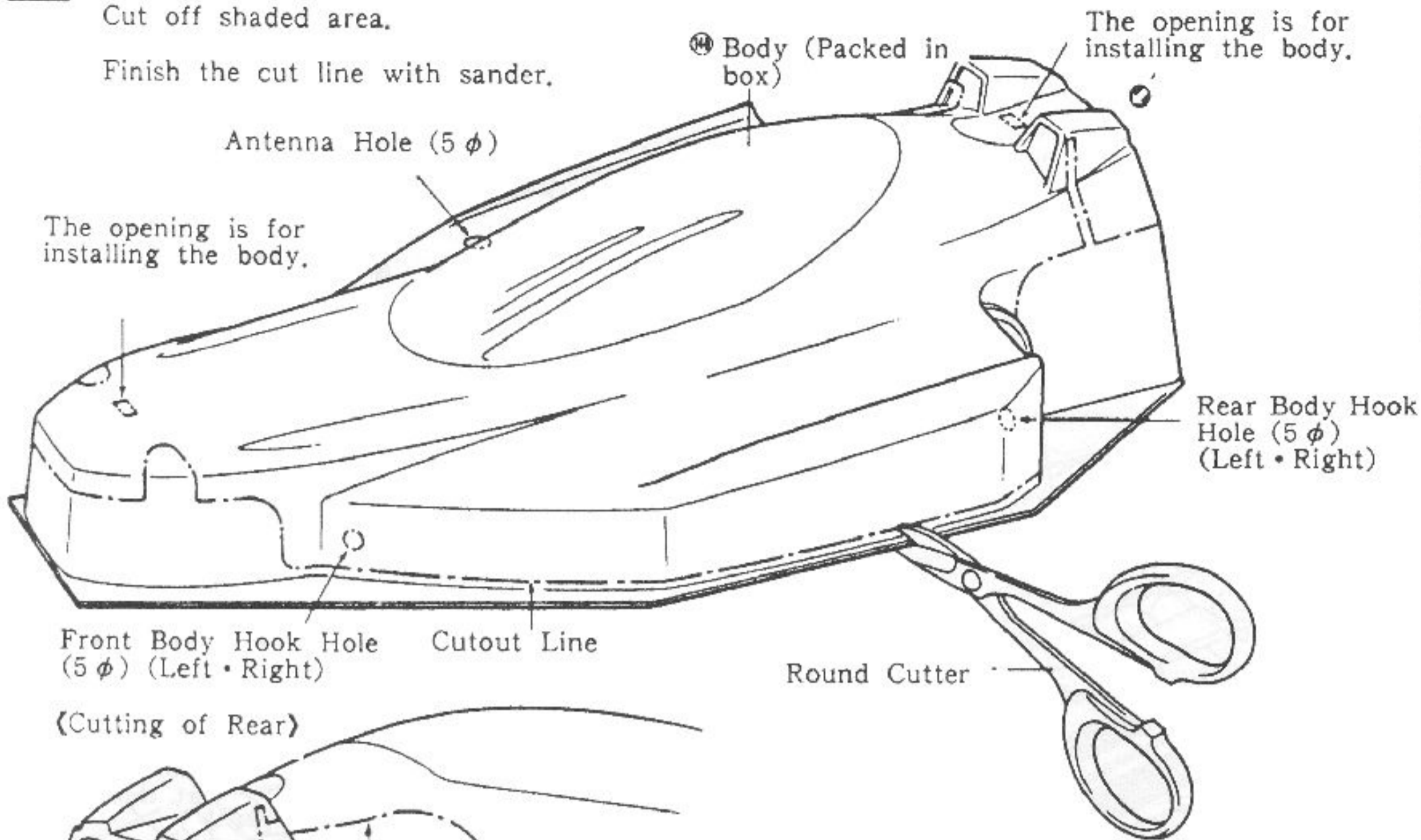

KYOSHO

These special Lexan Scissors make trimming bodies a breeze and the sander comes in handle for finishing the rough edges.

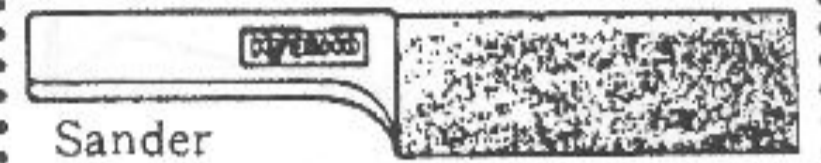
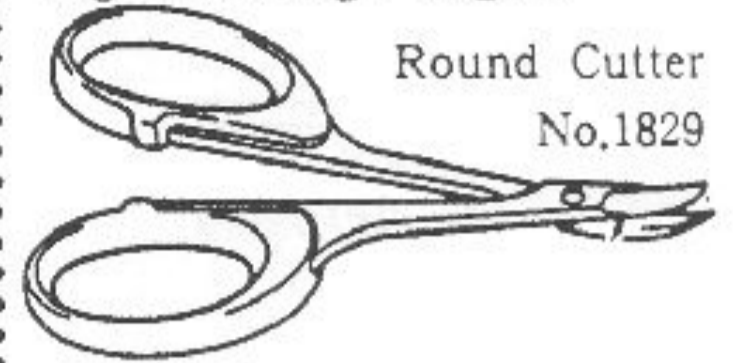

(Cutting of Rear)

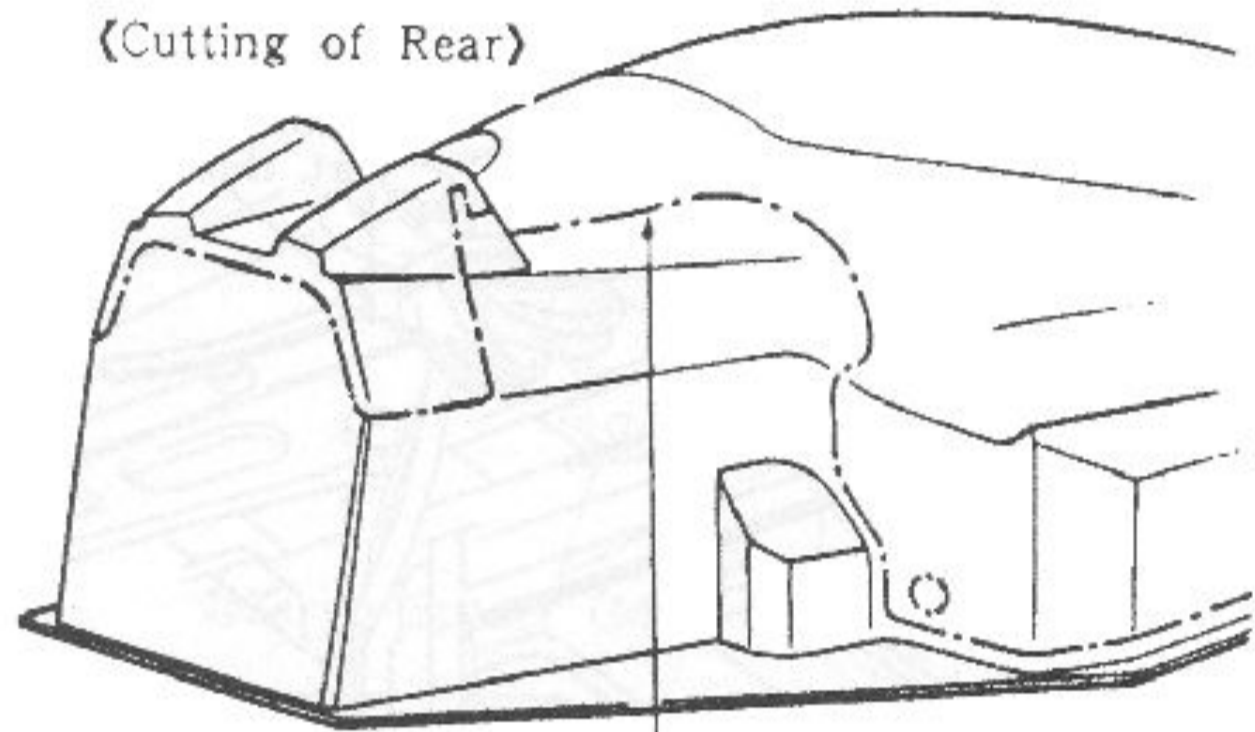

Under Cowl (Packed in box)

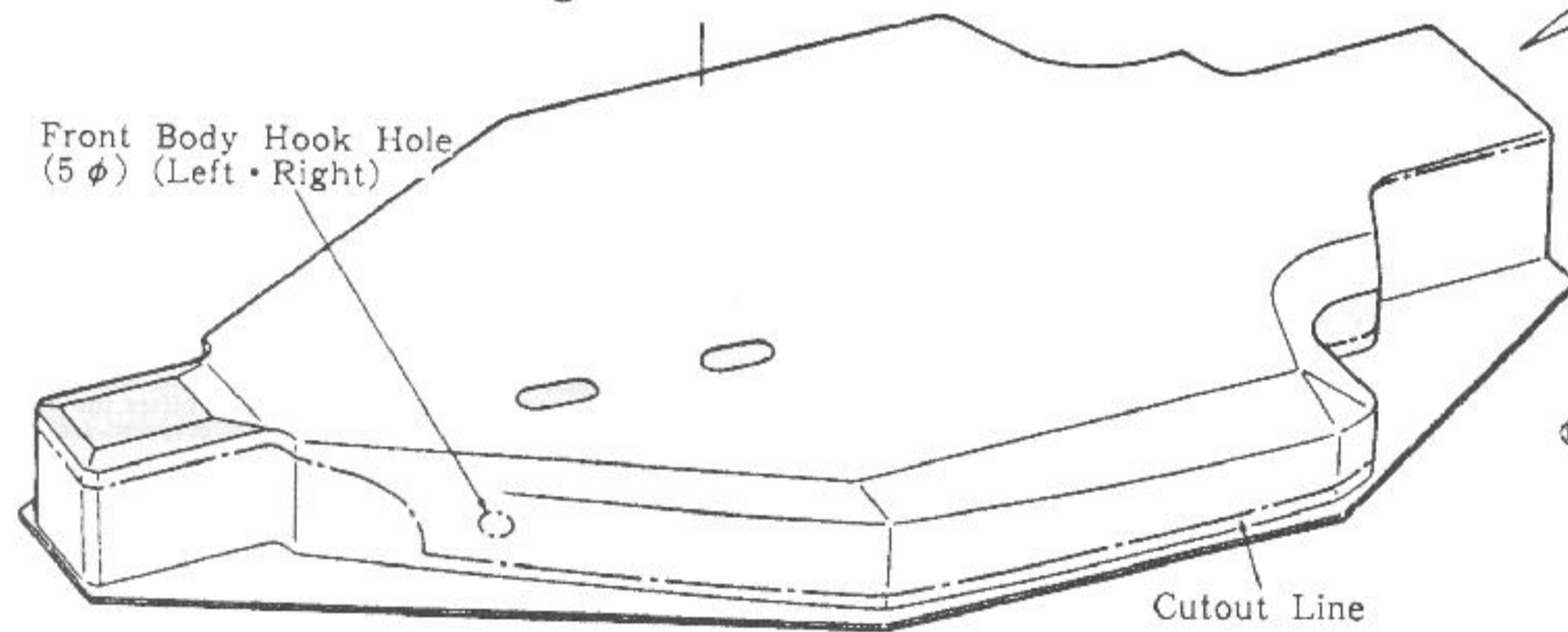

The opening is for installing the screw. (3 φ)

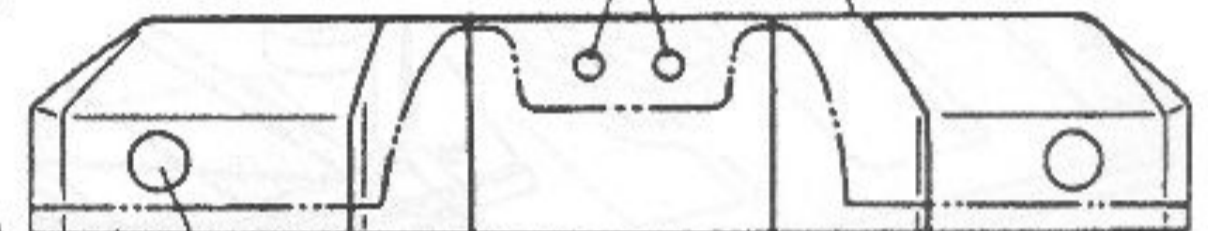

Rear Body Hook Hole (5 φ) (Left • Right)

The opening is for installing the wing. (5 φ)

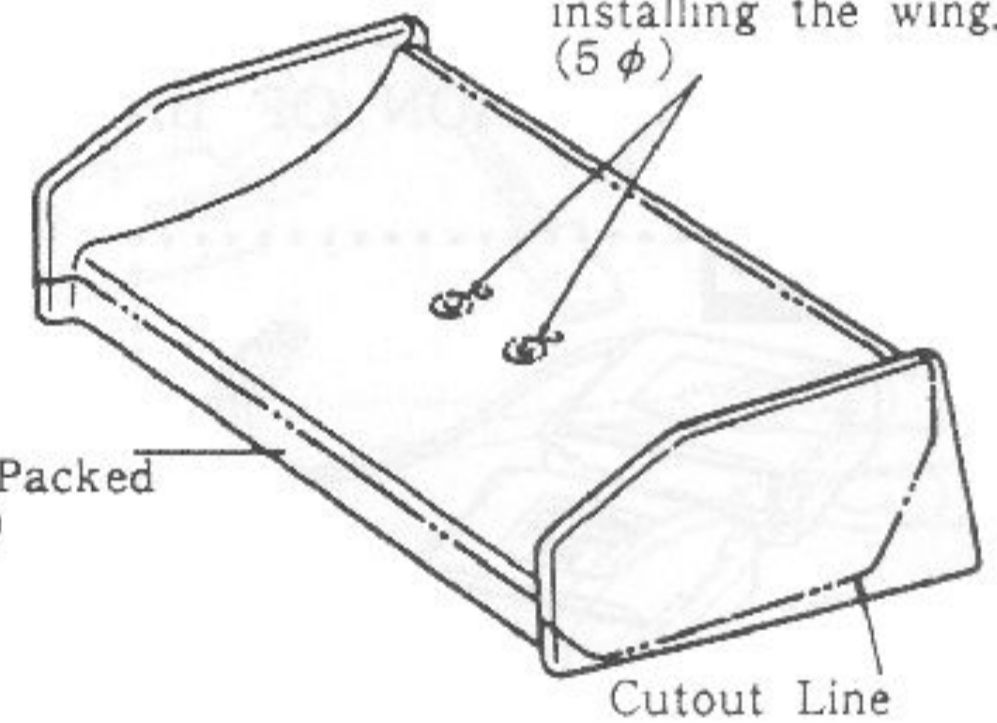

37 PAINTING

- ① Before painting, wash the body to remove any oil or dirt and rinse thoroughly.
- ② You can obtain a color scheme by masking a portion with tape then removing the tape and painting.
- ③ Paint the inside of the body to produce a smooth looking outer finish.
- ④ Use your darker colors first, then the lighter colors. This will prevent the darker colors from bleeding through the lighter colors.

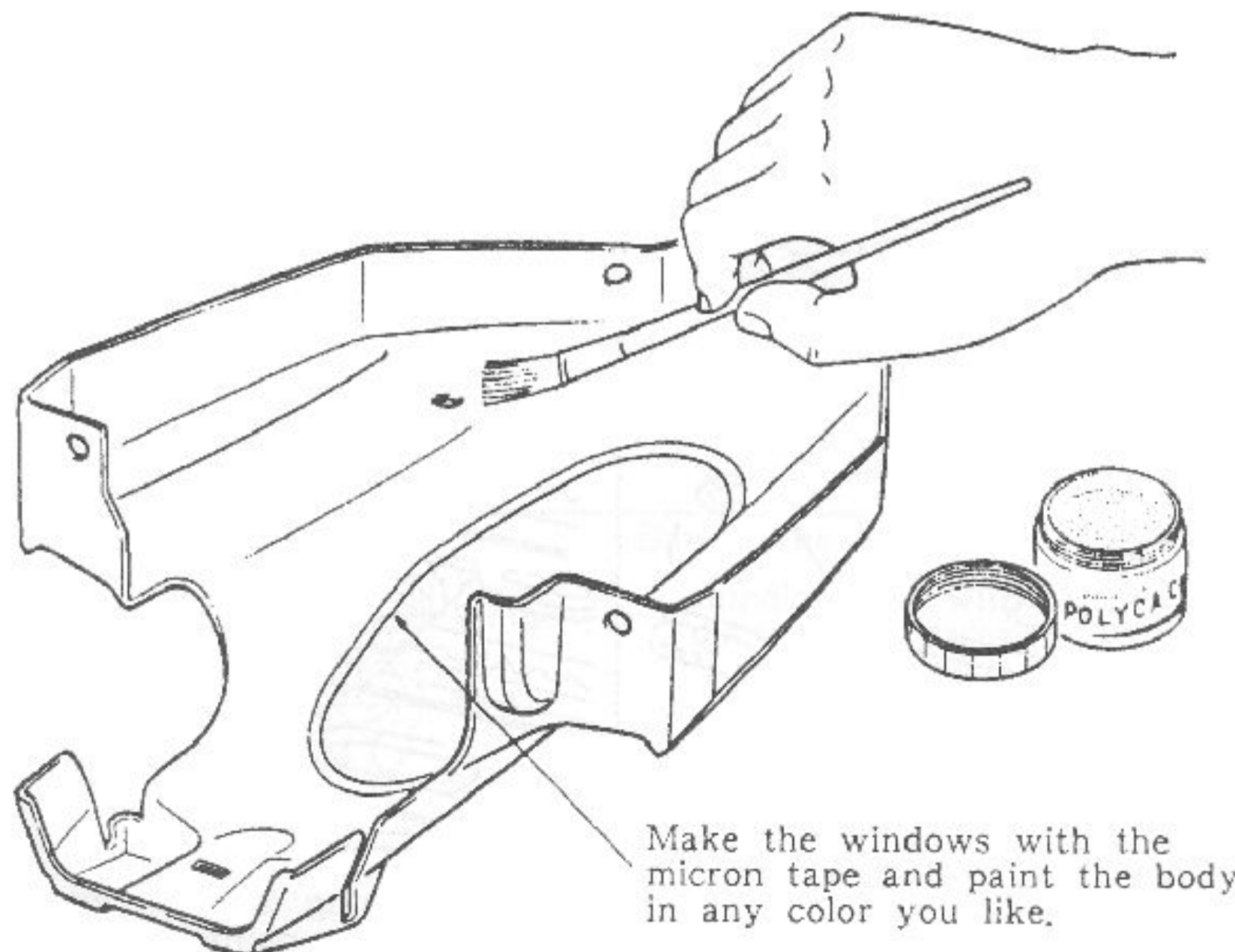

Make the windows with the micron tape and paint the body in any color you like.

KYOSHO

- Micron Line Tape
- No.1841...1.00mm
- No.1842...1.5mm
- No.1843...2.5mm
- Color
- White, Red, Yellow, Green, Blue & Black



KYOSHO

Polica Color No.2230

- WWhite, Red, Yellow, Green, Blue, Sky Blue, Orange, Black, Violet, F. Pink, Yellow Green & F. Orange.



38 APPLY OF DECAL

[Hints for Applying Decals]

Cut off the decals along the cutout line with scissors.

Do not apply it abruptly. Convince yourself of the position by trying the decals with the backing paper on.

Be careful not to have air bubbles left. Try to smooth out the decal's surface from the center to the periphery. (Particularly be cautions with a large decal.)

Cut off body hook hole.

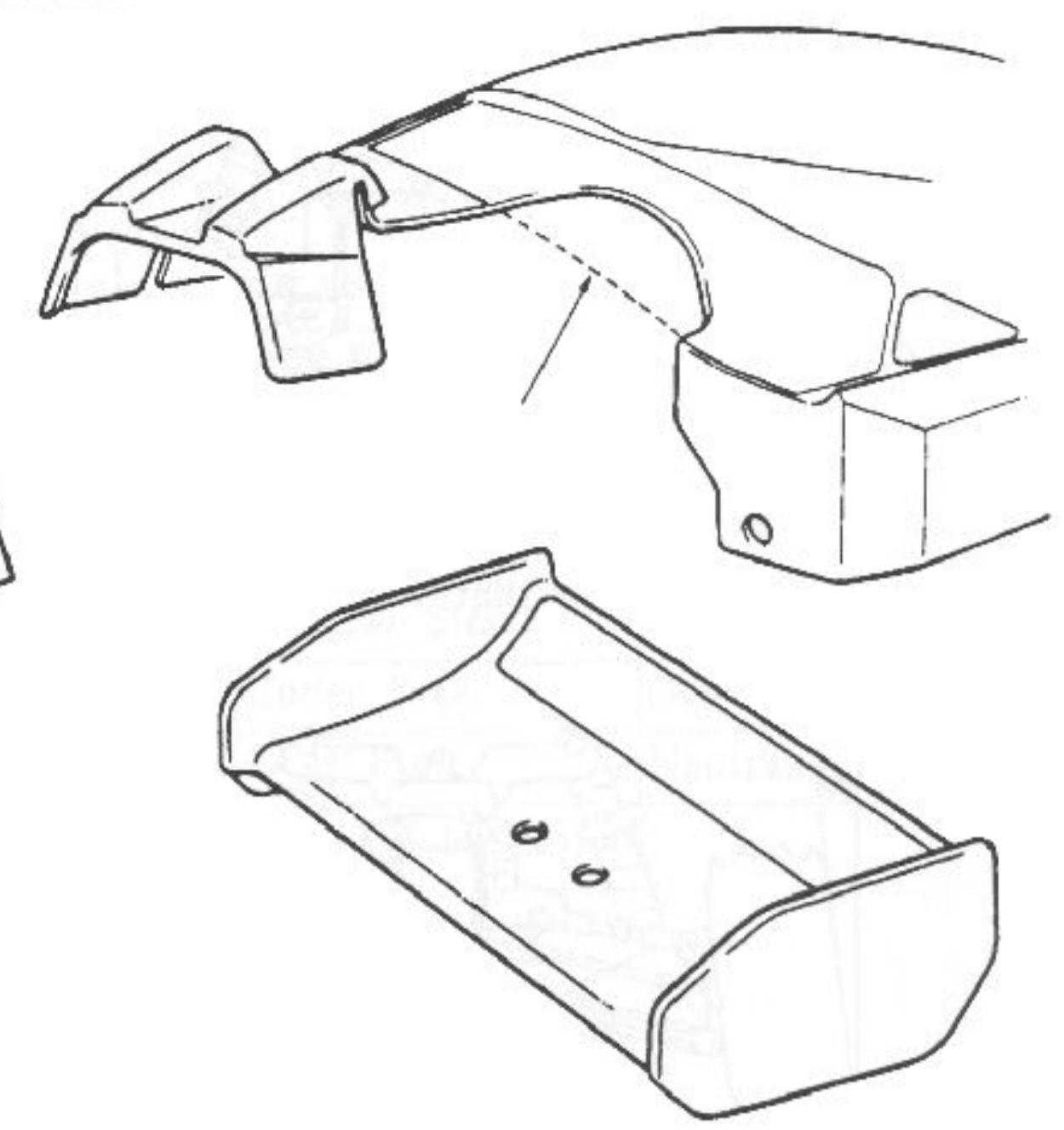
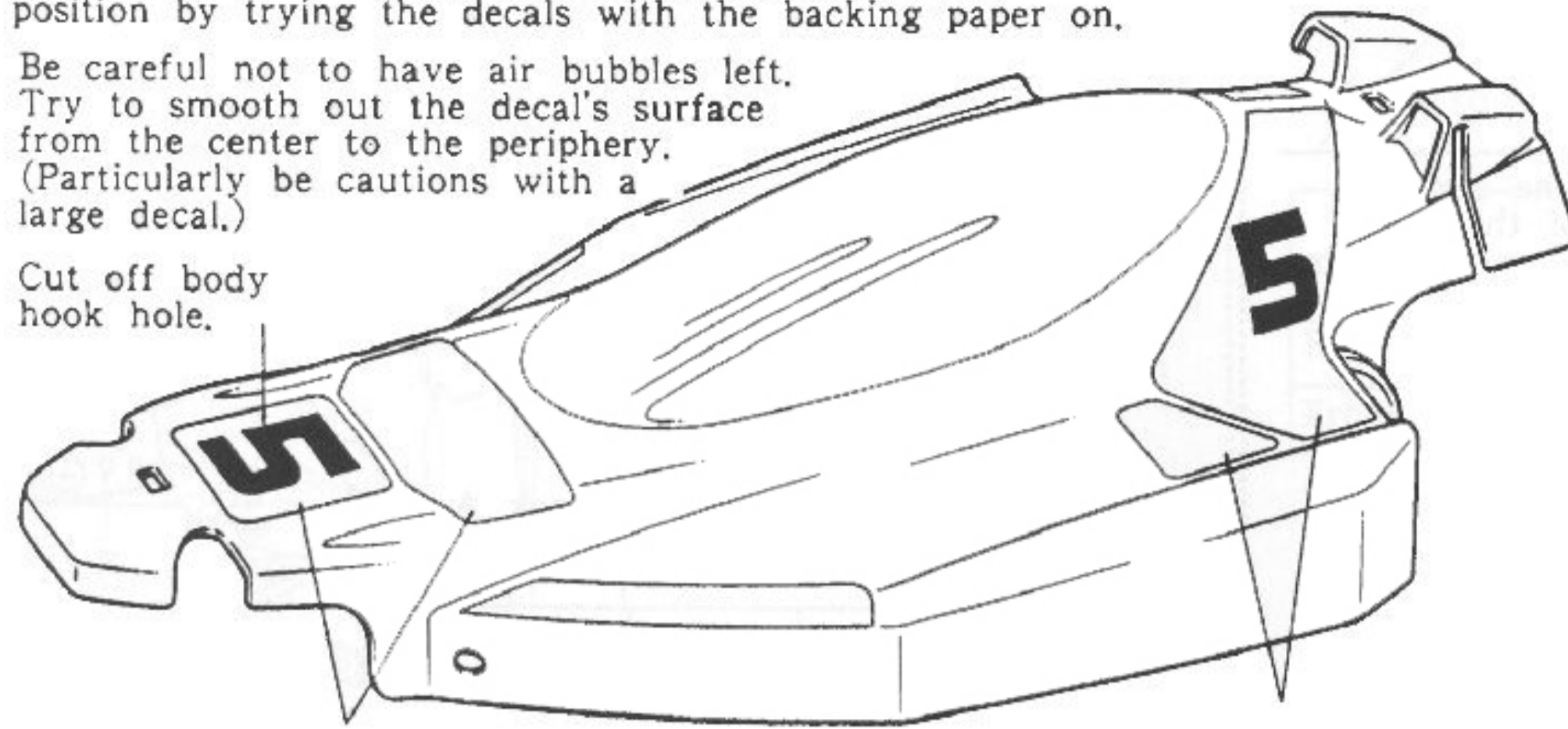

39 INSTALLATION OF UNDER COWL BODY AND WING

Bend hook pins like the picture.

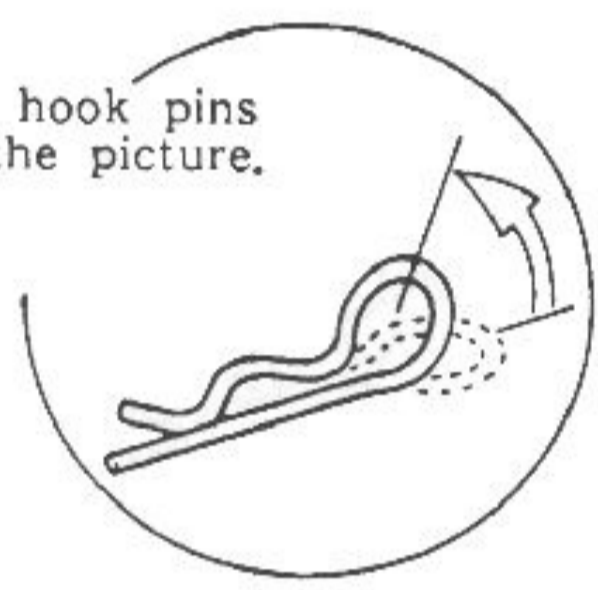

④ Body Pin (MCS-1)

70 Wing Washer (MCS-6)

④ Hook Pin (MCS-1)

Fix 70 with the flat surface downward.

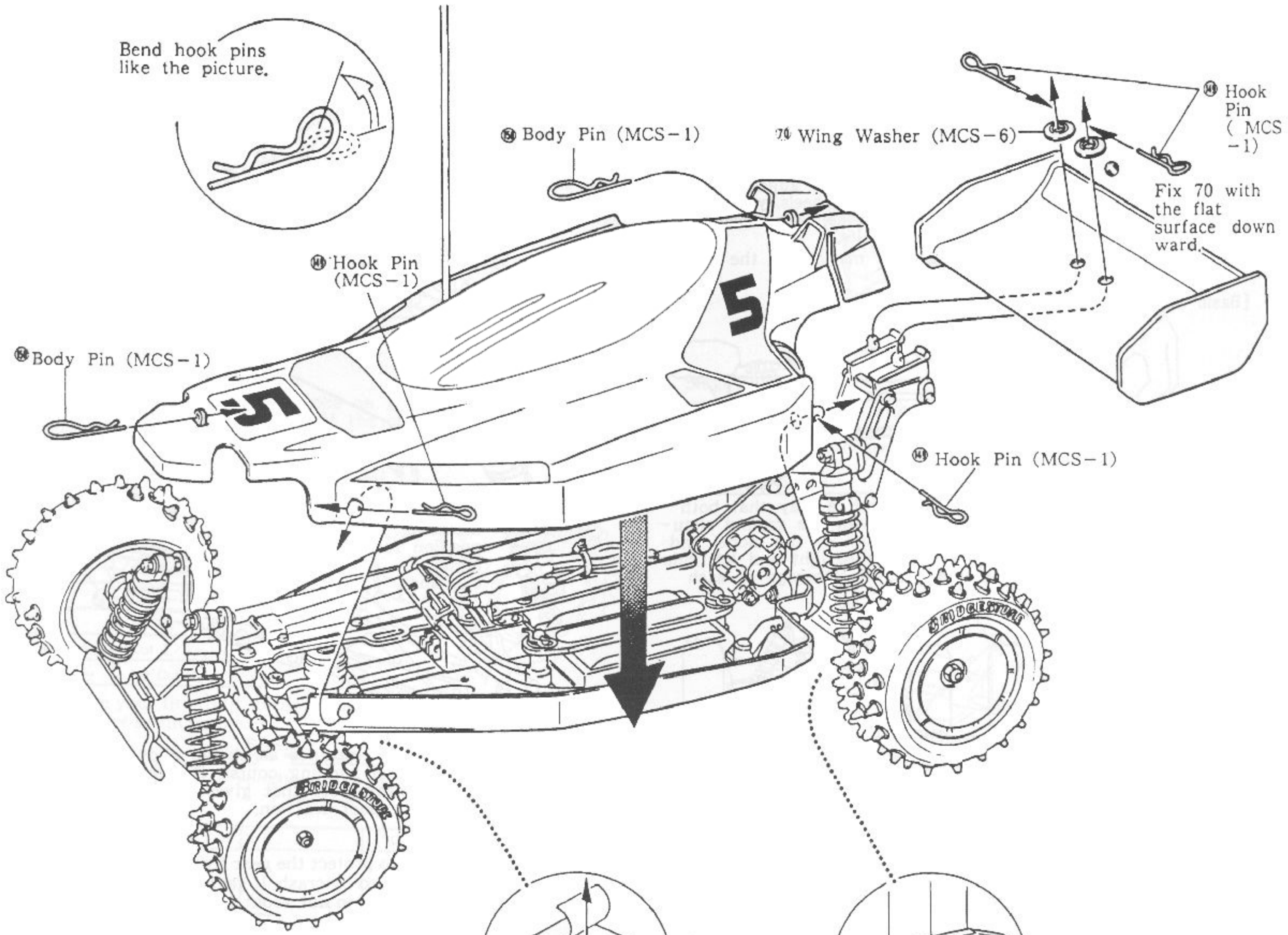

- ④ Wing Washers... 2
- ④ Hook Pins... 6
- ④ Body Pins... 2

GUIDE FOR SET UP (1)

Basic Setting 1]

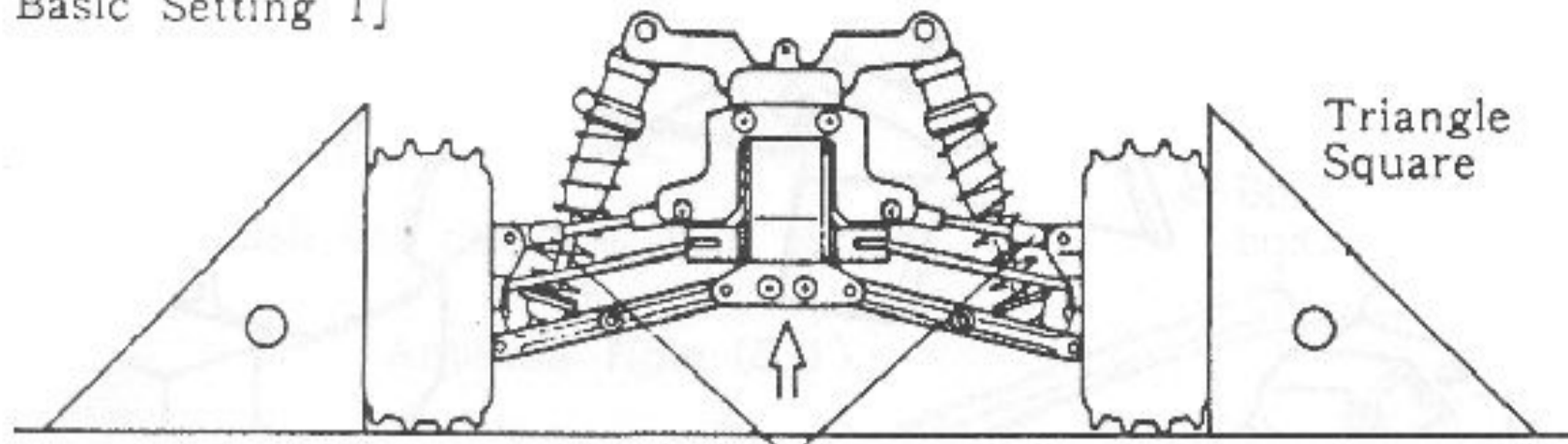

Place the model car on a flat surface, and keep the car with the maximum body clearance, and adjust length of the front and rear upper rods so that the wheels stand at a right angle to the ground.

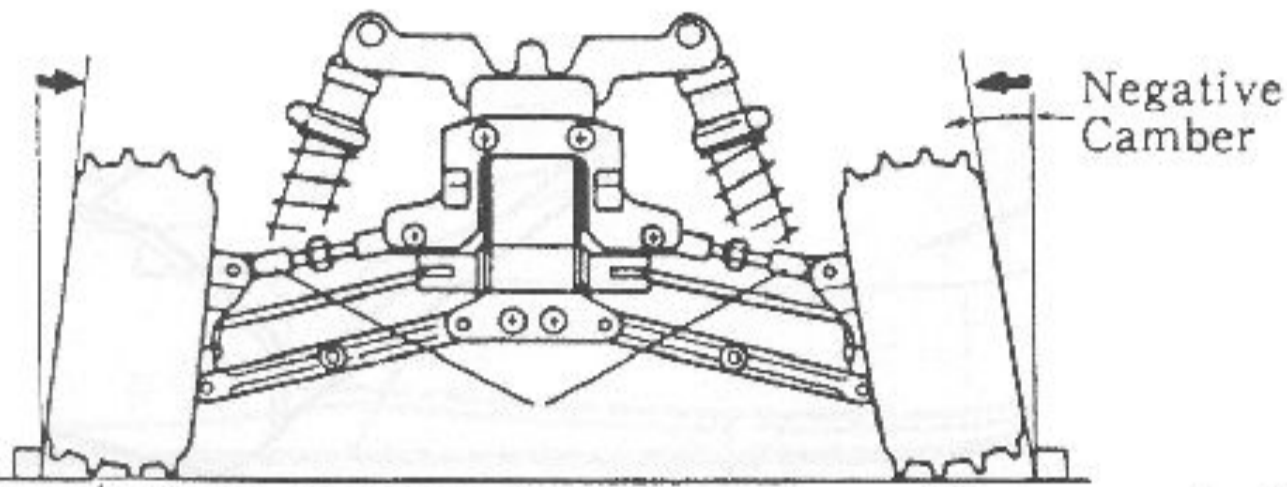

By adjusting the upper rod shorter, you will have a trait of negative camber. With negative camber adjustment on the front wheels, you will have sharper steering tendency, while on the rear wheel, the gripping power becomes bigger.

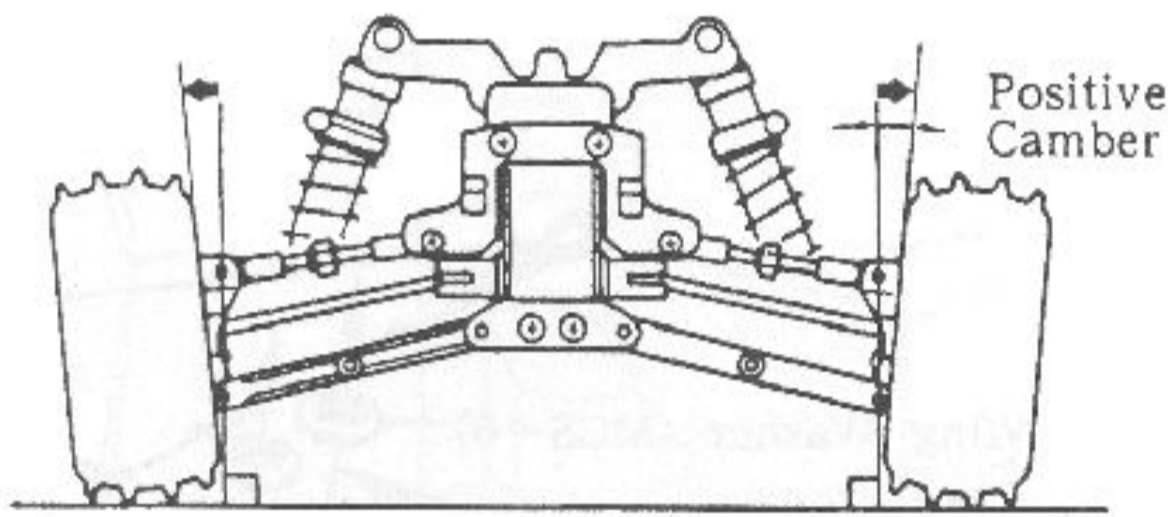

By lengthening the upper rod, positive camber adjustment is gained. With positive camber on the front wheels, you will have a trait of under steering, while on the rear wheels you will have the car with over steering traits.

*Excessive positive camber adjustment may make the swing shaft dislocated.

[Basic Setting 2]

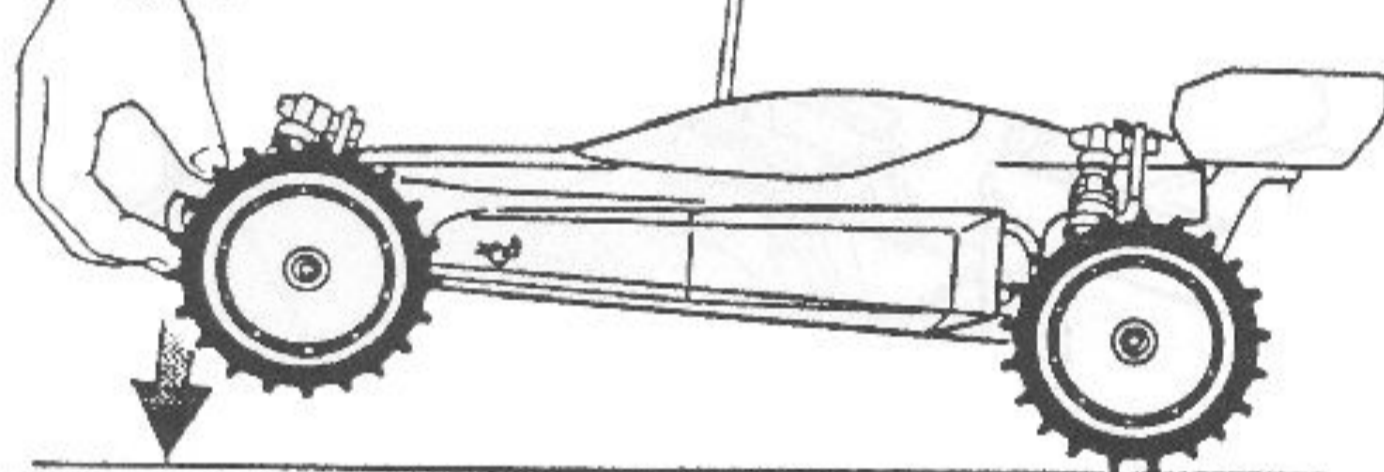

Adjust the right and left shocks in such a way that both sides of the front wheels will touch down the ground simultaneously when raising the front portion of the model and lowering it down gently. In the case the right and left side wheels land not in the same instant, the steering of each wheel won't be same.

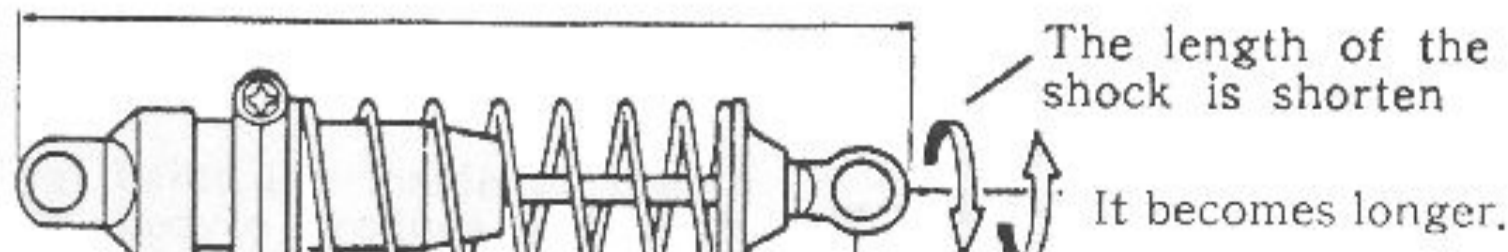
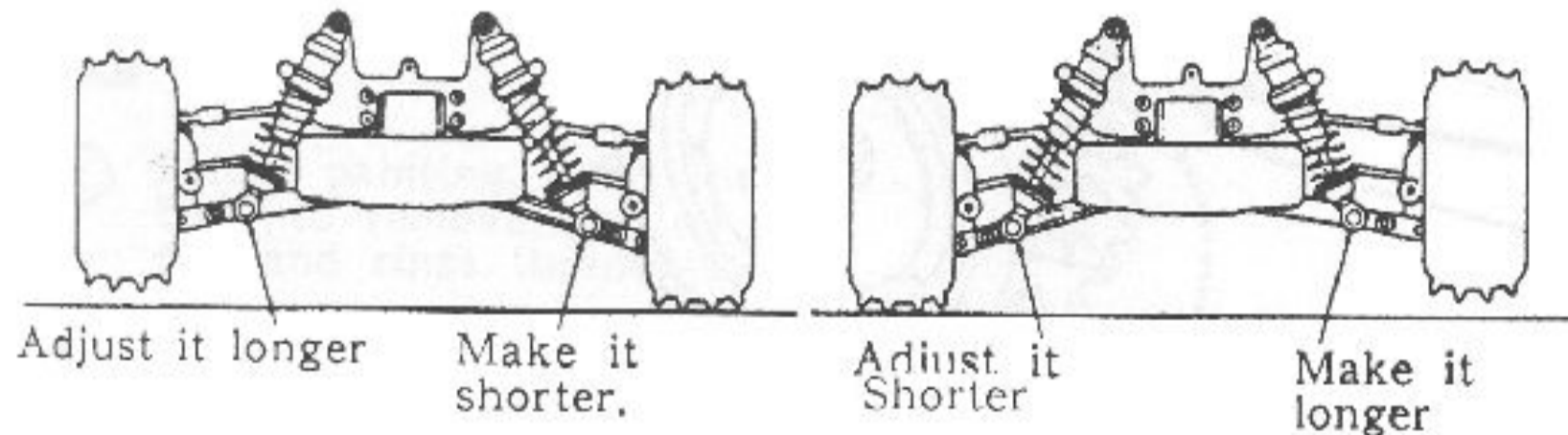

Turn the shock end in or out for the adjustment, Shock End

Leave the clearance of 5mm to 10mm here.

Loosen this screw for the adjustment. (Adjust the right and left sides to the same degree.)

Adjustment of Shock Oil and Spring]

- Front (With lighter shock oil) → Quicker steering response
- Front (With less spring tension) → Slower steering response
- Front (With heavier shock oil) → Slower steering response
- Front (With more spring tension) → Quicker steering response
- Rear (With lighter shock oil) → More traction
- Rear (With less spring tension) → More traction
- Rear (With heavier shock oil) → Less traction
- Rear (With more spring tension) → Less traction

[Adjustment of Hardness of Shock Action]

*Take this chart just as general indication.

No.1951 Oil Set	Yellow	Green	Yellow	Red	Green	Red
Piston						
Hardness	← Harder			Softer →		

[Adjustment of Car Clearance] Adjust it with the binding screws.

(1) Adjustment of front clearance

Installing position for lower clearance. (This is the position as shown in the instruction.)

For higher clearance... Use the lower hole.

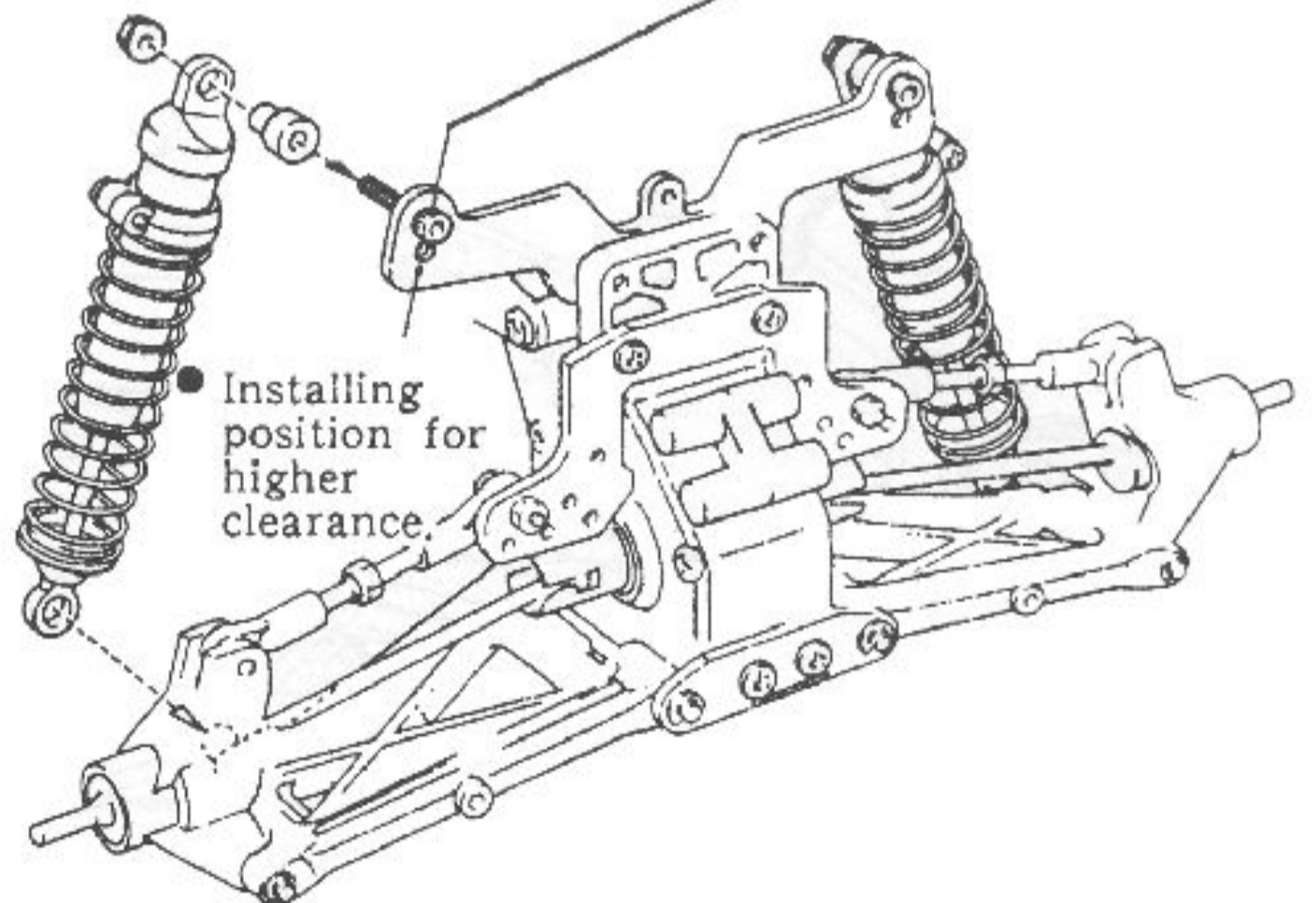
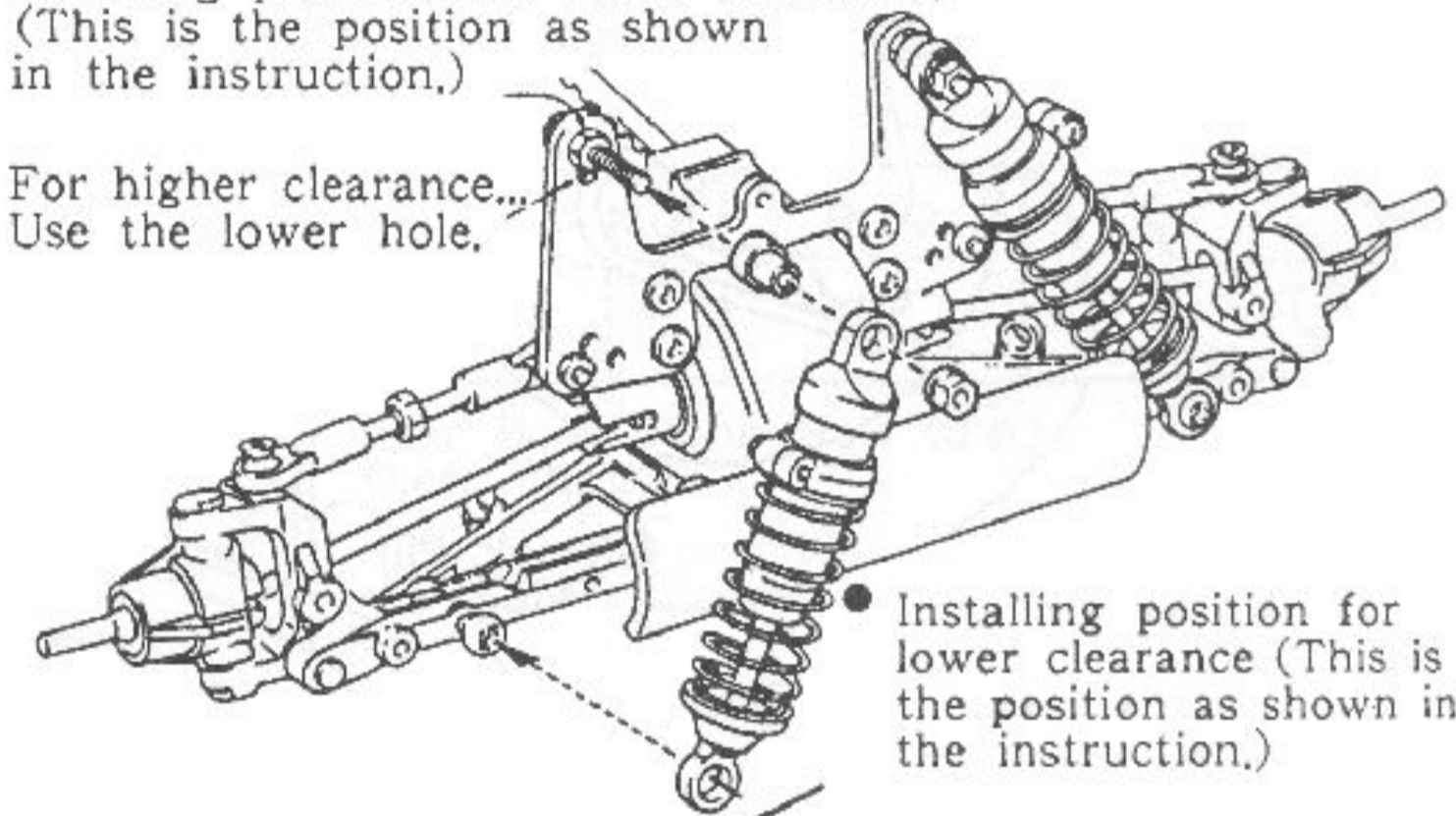

* You can adjust the car clearance as shown above depending upon the conditions of a running course. Generally speaking, low clearance for turf or anywhere that gives you a good traction, a high clearance for a poor traction.

[Concerning Gear Protector]

Gear protector's function to protect the gear from jump landing impact and from shock caused by crash. If gear slips, go back to page 9 and tighten the M3 nylon nut about 1/4 turn.

Pinion Gear	15	16	17	18	19	20	21	22	23	24	25
Gear Ratio	13.04	12.22	11.50	10.87	10.29	9.78	9.31	8.89	8.50	8.15	7.82
Proper Motor	Le Mans Speed 240T SPA240W										
							Le Mans H240S				
					Le Mans 240ST						
	Le Mans 360GOLD										

GUIDE FOR SET UP (2)

[Correlation between installing Position of the Front Upper Rod and Camber Angle]

The installing points A, B, and C on the front shock stay for the upper rod correspond to A', B' and C' which are the maximum camber angle when the front suspension arms swing down to the lowest position.

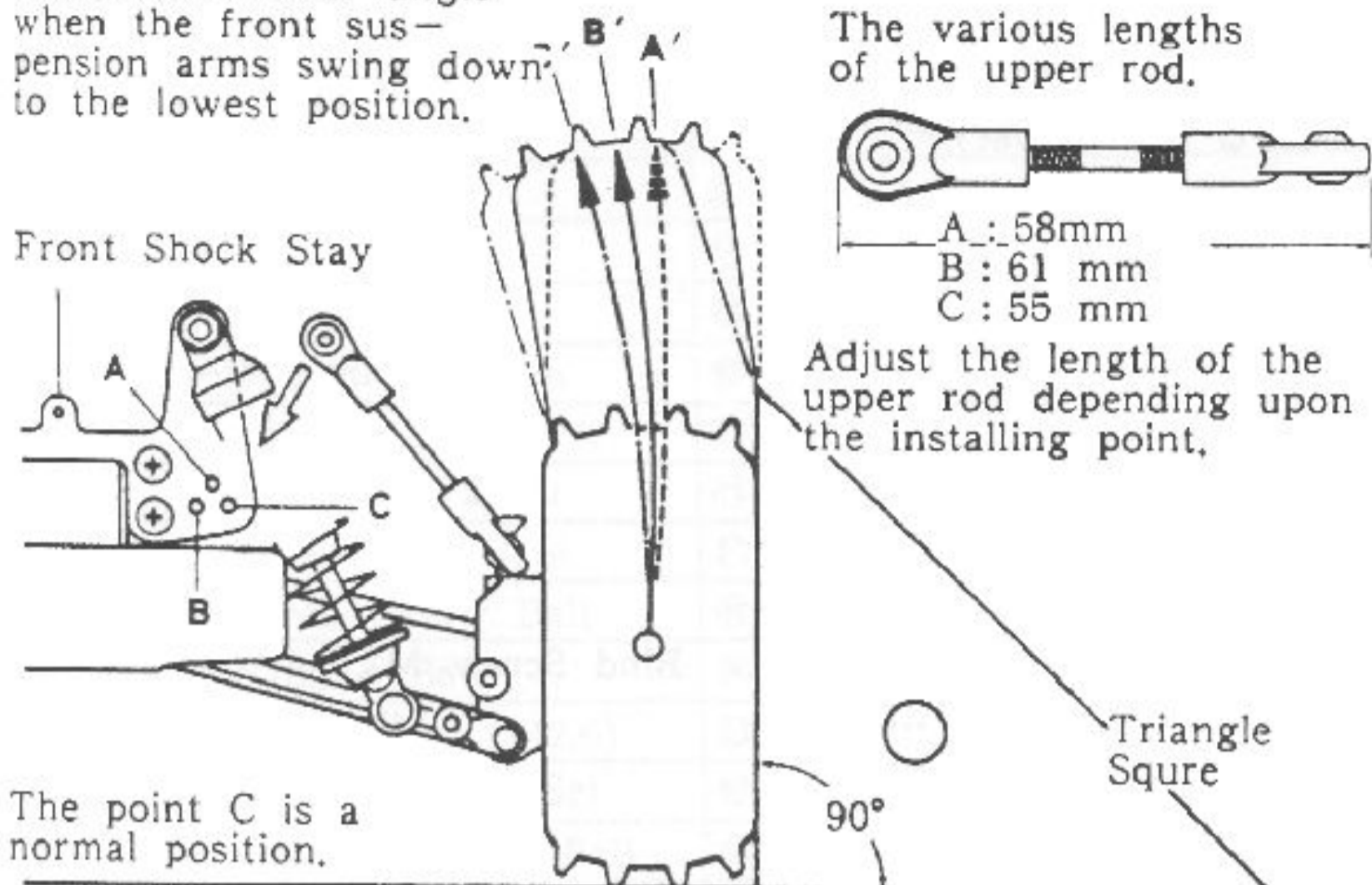

[Correlation between installing position of the Rear Upper Rod and Camber Angle]

The installing points A and B on the upper rod plate will result in the positions of the rear camber angle A' and B' when the rear suspension arms sink the most.

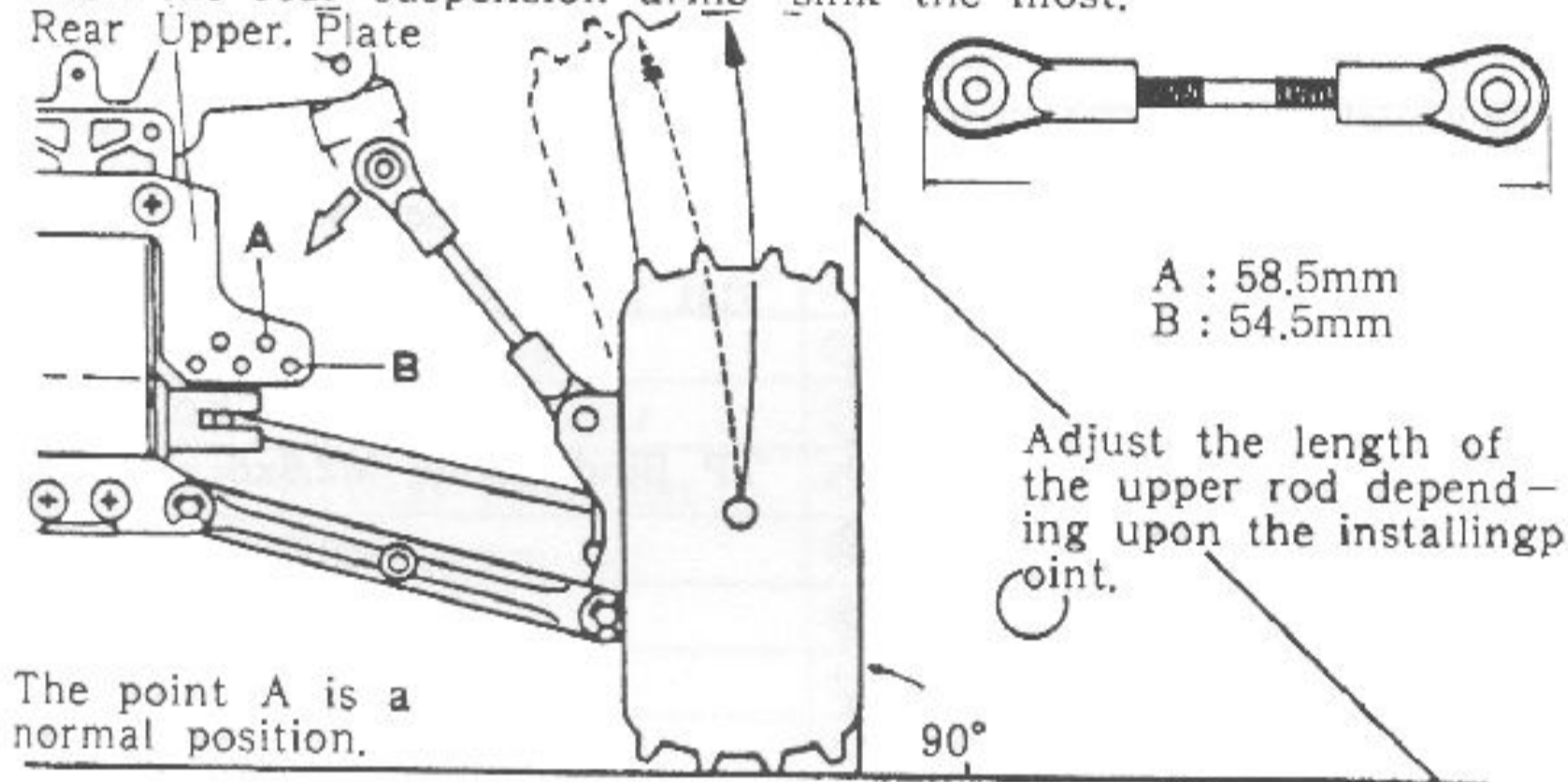

[Modification of Tire]

By changing the shape of the knobs on the tire, you can improve the running performance of the car.

*If your car displays the quick steering response, cut off the knobs by 1/2 to 1/3 then you can make it with milder response.

Type of Course Surface	Amount of Lowering Knob
Turf	Cut 1/2
Concrete	Cut 2/3
Sandy	No Cutting
Hard Dirt Track	Cut 1/3
Soft Dirt Tract	No Cutting

If you change your tire to fit to the condition of track surface, you can gain even wider setting range.

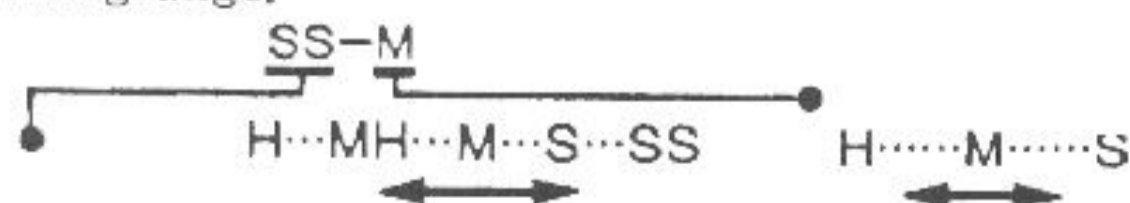

	H	MH	M	S	SS
W5034 Narrow Tire W5031 Low Profile Tire (Hard)					
W5076 Narrow Tire W5078 Low Profile Tire (MH-M)					
W5033 Narrow Tire OT-66 Low Profile Tire (Pin Type)					
W5032 Low Profile Tire (Soft)					
W5075 Narrow Tire W5077 Low Profile Tire (SS-M)					

[Adjustment of Differential Gear]

This model's differential is gear type, and adjustable by the oil amount and hardness of the oil.

To make hard...Use 1956 silicon (Super hard) Oil a little bit more than usual.

To make softer...Mix 10% to 20% of the silicon oil (II) with differential oil.

	Low Speed Corner	High Speed Corner
Front Diff.(Hard)	Neutral Steer	Under Steer
Rear Diff.(Hard)	Under Steer	Over Steer
Front Rear (Soft)	Over Steer	Neutral Steer

*Take this chart just as general indication.

[Maintenance of Differential Gears]

Check and clear the differential frequently.

[Checking Inside of Gearbox]

The following illustration shows the necessary parts to take off and the steps for checking the gearbox.

Stage 1
Remove the screws and E-rings marked by *.

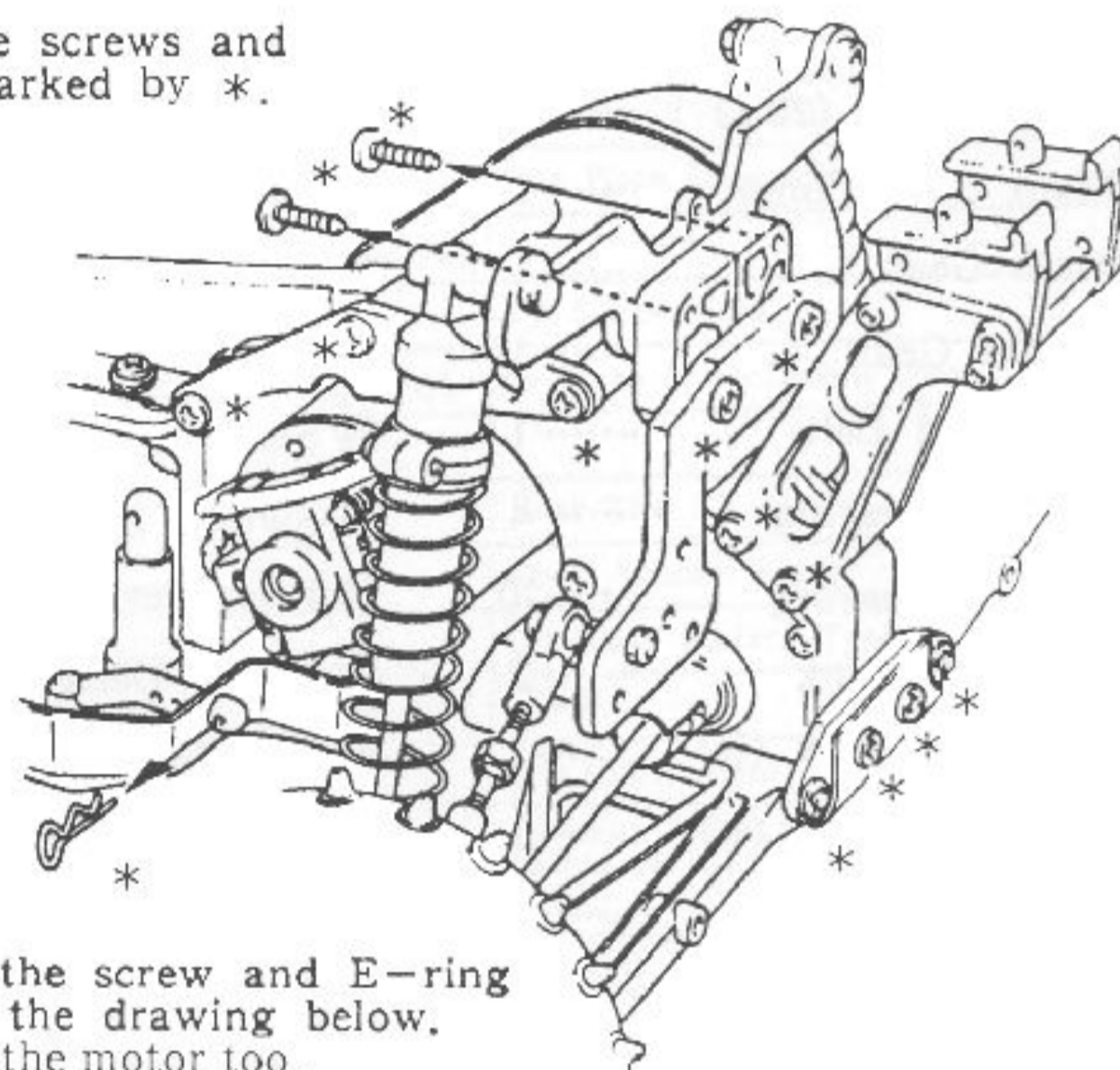

Stage 2
Take off the screw and E-ring shown in the drawing below. Dismount the motor too.

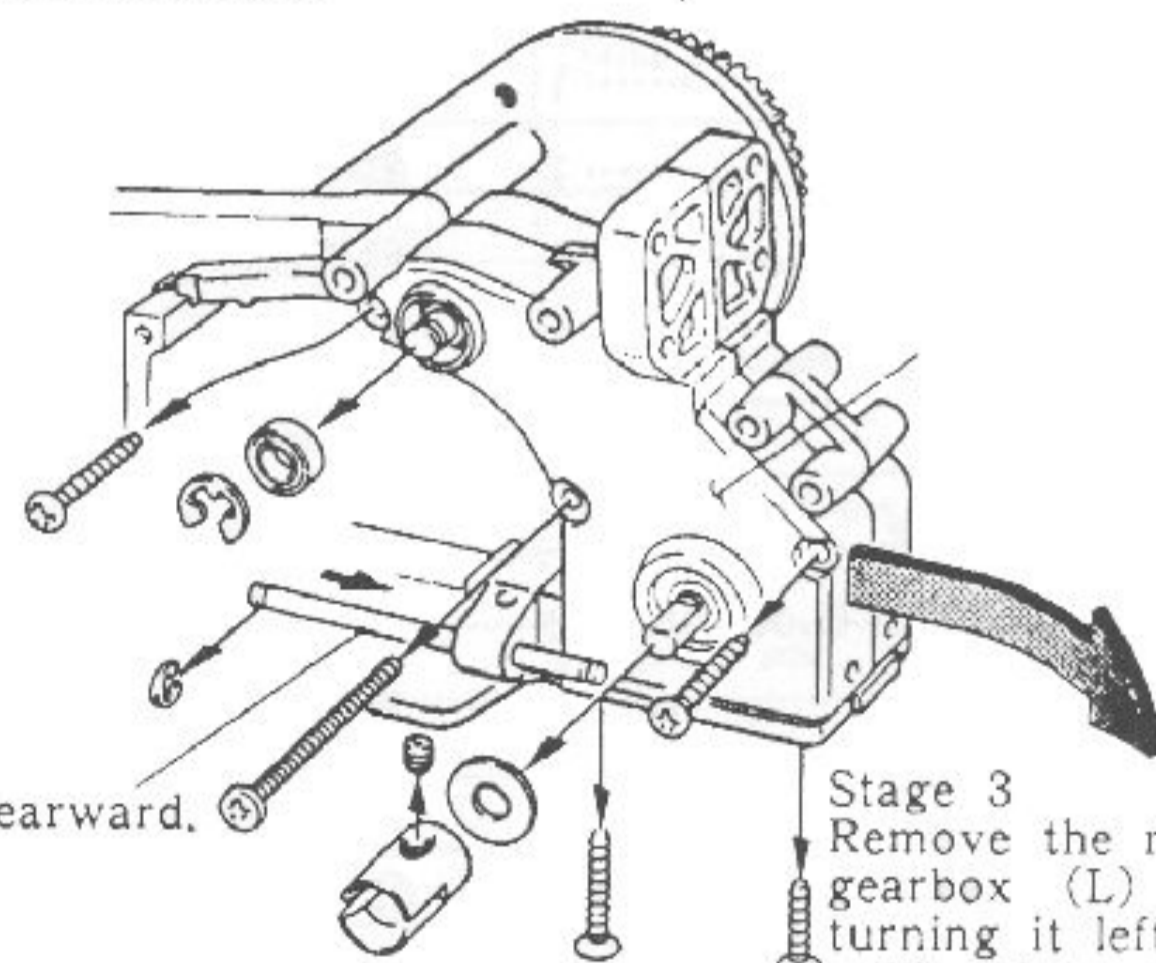

Stage 3
Remove the rear gearbox (L) by turning it left as pulling it rearward.

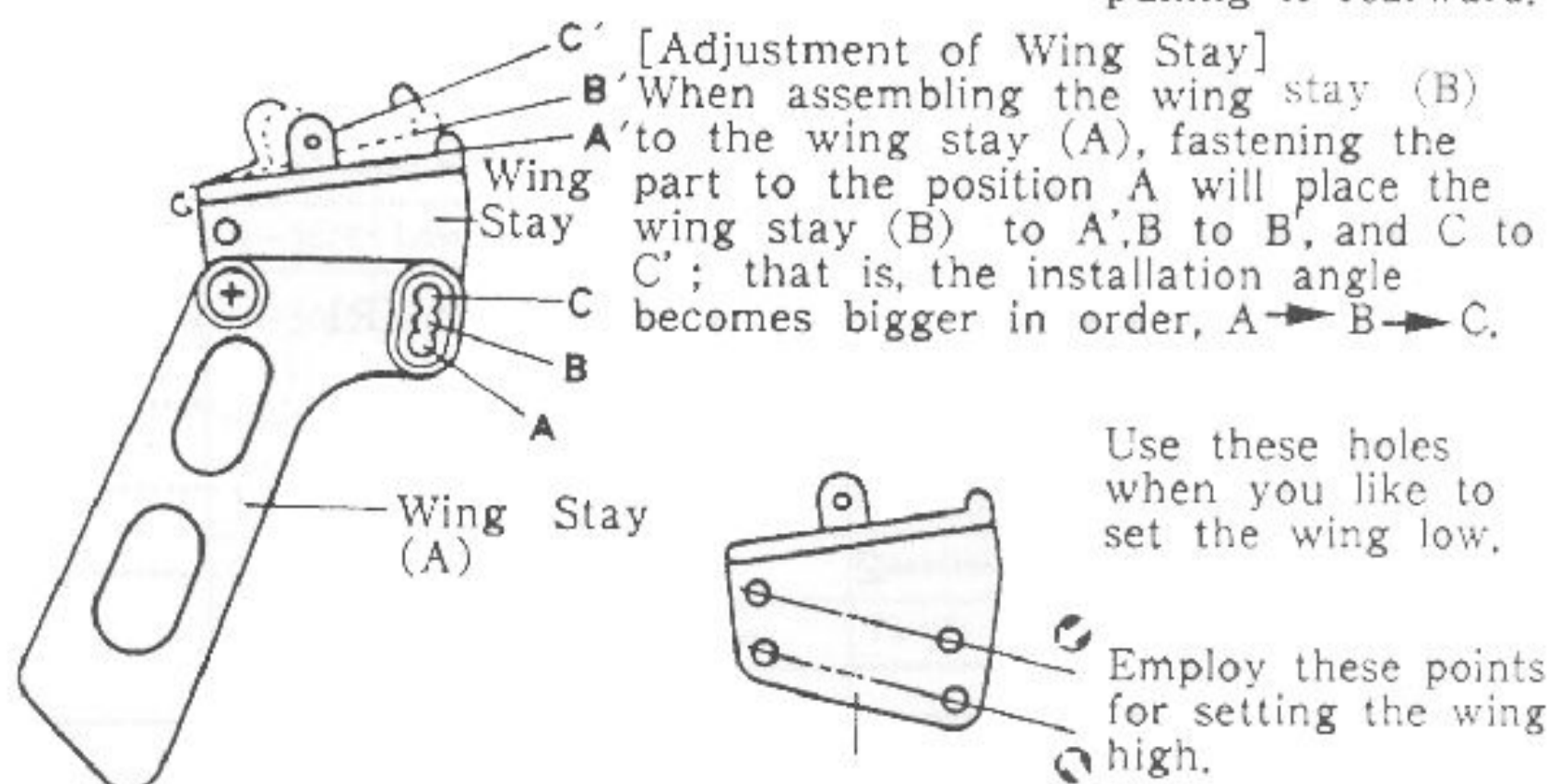

Key #	Part Name	Q'ty	Key #	Part Name	Q'ty	Key #	Part Name	Q'ty	Key #	Part Name	Q'ty
● ①	Front Shock Shaft	...2	⑤①	Upper Deck Post2	⑩①	Front Sus. Shaft (A) (Silver)	...2	⑩⑤	Hex Key1
● ②	Rear Shock Shaft	...2	⑤②	Rear Wheel Shaft2	⑩②	Rear Sus. Shaft (A) (Black)	...2	⑩⑥	Hex Key (2)1
● ③	Front Shock Case2	⑤③	Ball Nut3	⑩③	M3 Pillow Ball (Silver)4	⑩⑦	Hex Key (2.5)1
● ④	Rear Shock Case2	⑤④	Rear Plate (R)1	⑩④	M2.6 Pillow Ball (Black)	...4	⑩⑧	Servo Stay Collar2
● ⑤	Front Shock Spring	...2	⑤⑤	Front Shock Stay1	⑩⑤	5.8 φ Ball (silver)4			
● ⑥	Rear Shock Spring	...2	⑤⑥	Rear Shock Stay1	⑩⑥	Ball End (L)12			
● ⑦	Spring Holder4	⑤⑦	Rear Upper Plate1	⑩⑦	Ball End (S)3			
● ⑧	Shock Cap4	⑤⑧	Rear Sus. Plate1	⑩⑧	Front Sus. Shaft (B)	...2			
● ⑨	Spring Stopper4	⑤⑨	Front Sus. Plate1	⑩⑨	Rear Sus. Shaft (B)	...2			
● ⑩	Shock End4	⑥①	Gear Protector Plate (A)	...1	⑩⑩	Main Chassis1			
⑩⑪	Front Diff. Case1	⑥②	Motor Plate1	⑩⑪	Upper Deck1			
⑩⑫	Rear Diff. Case1	⑥③	Pully Flange (Yellow)1	⑩⑫	Belt Cover (A)1	Bind Screw M2.6x4	...4	
⑩⑬	Sprocket2	⑥④	5 φ Collar (L) (Yellow)	...1	⑩⑬	Belt Cover (B)1	M2.6x6	...1	
⑩⑭	Diff. Ring (Yellow)2	⑥⑤	5 φ Collar (S) (Yellow)	...1	⑩⑭	Gear Cover1	M2.6x12	...4	
⑩⑮	Bevel Gear (A)4	⑥⑥	Pully (Yellow)1	⑩⑮	One Touch Tape4	M3x6	...2	
⑩⑯	Bevel Gear (B)4	⑥⑦	Wing Stay (A) (R)	...1	⑩⑯	Motor Cord (Red,White)	1set	M3x10	...4	
⑩⑰	Bevel Shaft2	⑥⑧	Wing Stay (A) (L)	...1	⑩⑰	Front Sus. Arm2	M3x30	...2	
⑩⑱	Drive Washer4	⑥⑨	Wing Stay (B)2	⑩⑱	Rear Sus. Arm2	M3x35	...1	
⑩⑲	Joint4	⑦①	Wing Stay Joint	...2	⑩⑲	Antenna Pipe1	M3x45	...2	
⑩⑳	Pinion Gear (20T)1	⑦②	Wing Washer2	⑩㉑	Knuckle Arm (R)1	M4x12	...2	
⑩㉑	Main Gear Pinion1	⑦③	Battery Holder2	⑩㉒	Knuckle Arm (L)1	Round Head Screw M3x4	...2	
⑩㉒	Main Gear1	⑦④	Servo Spacer2	⑩㉓	Saver Spring1	Flat Head Screw M3x6	...4	
⑩㉓	Center Gear1	⑦⑤	Front Stabilizer2	⑩㉔	Electric Condenser1	M3x12	...2	
⑩㉔	Thoothed Belt1	⑦⑥	Servo Stay Spacer2	⑩㉕	Rear Plate (L)1	TP Bind Screw M2.6x6	...6	
⑩㉕	8 φ x14 Bearing4	⑦⑦	Switch Holder1	⑩㉖	5 φ x8 Plain Bearing2	M2.6x12	...4	
⑩㉖	5 φ x10 Bearing10	⑦⑧	Rear Sus. Pivot1	⑩㉗	NiCd Strap2	M3x6	...3	
⑩㉗	4 φ x8 Bearing2	⑦⑨	Upper Deck Mount	...1	⑩㉘	3 φ x32 Adjust Rod	...4	M3x10	...19	
⑩㉘	Front Gearbox (R)	...1	⑦⑩	Belt Cover Stopper1	⑩㉙	3 φ x50 Adjust Rod	...2	TP Round Head Screw M3x18	4	
⑩㉙	Front Gearbox (L)	...1	⑦⑪	Battery Stopper2	⑩㉚	Universal Swing Shaft2	TP Flat Head Screw M2.6x6	...1	
⑩㉚	Rear Gearbox (R)1	⑦⑫	Stopper Post4	⑩㉛	Swing Shaft2	M3x6	...5	
⑩㉛	Rear Gearbox (L)1	⑦⑬	Stopper Washer (Thiner)	...4	⑩㉜	Shock Piston4	M3x10	...21	
⑩㉜	Sponge Tape2	⑦⑭	Stopper Washer (Thicker)	...4	⑩㉝	Shock Collar (White)4	M3x15	...3	
⑩㉝	Rubber Cover1	⑦⑮	Front Body Hook2	⑩㉞	Shock Collar (Black)4	Nut M2.6 (3 kinds)	...10	
⑩㉞	Steering Rod1	⑦⑯	Rear Body Hook (R)1	⑩㉟	Pressure Top4	M3	...4	
⑩㉟	Double Sided Tape1	⑦⑰	Rear Body Hook (L)1	⑩㊱	O Ring (P3 - Red)8	Nylon Nut M3	...1	
⑩㊱	Shock Oil (Green)	...1	⑦⑱	Belt Cover (C)1	⑩㊲	C Ring4	M4	...4	
⑩㊲	Strap (S)3	⑦㉑	Servo Saver (A)1	⑩㊳	Front Tire2	Washer M2,3 (Black)	...8	
⑩㊳	Silicon Grease1	⑦㉒	Servo Saver (B)1	⑩㊴	Rear Tire2	M3	...4	
⑩㊴	Screw Cement (Loctite)	...2	⑦㉓	Servo Saver (C)1	⑩㊵	Wing1	M4	...2	
⑩㊵	Front Wheel2	⑦㉔	Servo Saver (D)1	⑩㊶	Body1	M5	...4	
⑩㊶	Rear Wheel2	⑦㉕	Servo Saver Collar2	⑩㊷	Under Cowl1	Set Screw M3x3	...1	
⑩㊷	Servo Saver Shaft2	⑦㉖	M3 Plastic Nut4	⑩㊸	Decal1	M4x4	...4	
⑩㊸	Main Gear Shaft1	⑦㉗	Servo Stay4	⑩㊹	E Ring (E2.5)20			
⑩㊹	Gear Protector Plate (B)	...1	⑦㉘	Shock Collar4	⑩㊺	E Ring (E3) (Black)2			
⑩㊺	Gear Protector Collar1	⑦㉙	Antenna Post1	⑩㊻	E Ring (E4)4			
⑩㊻	Center Gear Shaft1	⑦㉚	Shock1	⑩㊼	M2x10 Shaft1			
⑩㊼	Gear Protector Washer	...2	⑦㉛	Front Hub (R)1	⑩㊽	5 φ Shim8			
⑩㊽	King Pin4	⑦㉜	Front Hub (L)1	⑩㊾	Wave Washer3			
⑩㊾	5.8 φ Ball (Black)4	⑦㉝	Rear Hub (R)1	⑩㊿	Hook Pin10			
⑩㊿	2 φ x11 Pin2	⑧①	Rear Hub (L)1	⑪①	Body Pin2			

NOTE:
The parts showing work ● are temporary pre-assembled.

The parts showing work ◎ are packed in the Blister-pack (Bubble-pack)

The parts showing work ※ are including spares besides indicated quantity.

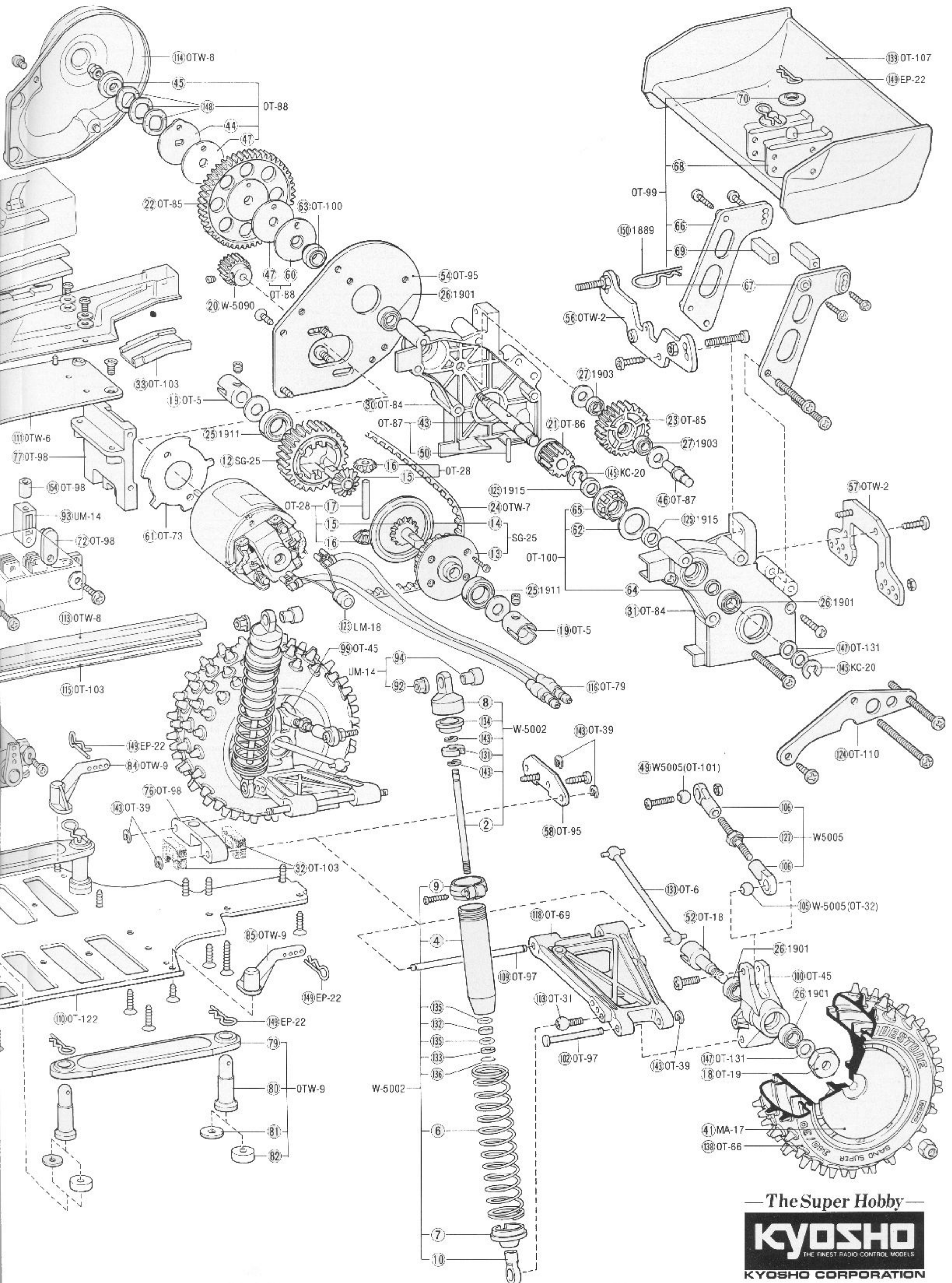

—The Super Hobby—

KYOSHO
THE FINEST RADIO CONTROL MODELS

KYOSHO CORPORATION

PURCHASABLE PARTS FOR YOUR KIT

You can purchase replacement and optional parts for your kit. All of the part identified by key number are usually not available singularly, but we offer these parts as convenient parts "packs" which can be purchased separately. To figure out which parts pack you need, find the key number for that part with the manual.

Then consult out parts pack guide below. When referring to the parts you need, always use the Parts Pack Number. For example, if you need a King Pin (Key #48) ask your dealer for Kyosho Parts Pack OT-4 (King Pin).

No.	Parts Name	Key No. & Qty.
OT-4	King Pin	④×4
OT-5	Joint	⑤×2
OT-6	Swing Shaft	⑥×2
OT-16	Knuckle Arm	⑬ ⑭
OT-18	Rear Shaft	⑰×2
OT-19	Drive Washer	⑱×4
OT-28	Diff. Gear Set	⑲×2 ⑳ ㉑×4
OT-31	M3 Pillow Ball	㉒×10
OT-32	5.8 φ Ball	㉓×10
OT-33	Ball Nut (M2.6)	㉔×10
OT-35	Upper Rod Set	㉕×4 ㉖×2 ㉗×8
OT-36	M2.6 Pillow Ball	㉘×10
OT-38	Silicon Grease	㉙×2
OT-39	E Ring (E2.5)	㉚×10
OT-45	Rear Hub	㉛ ㉜×1
OT-55	Front Hub Set	㉝ ㉞×1
OT-66	Low Profile Tire (Pin Type)	㉟×2
OT-69	Sus. Arm Set (Strong)	㊱ ㊲×2
OT-73	Motor Cleaner Set	㊳×1
OT-79	Motor Cord	㊴×2
OT-84	Gearbox	㊵ ㊶ ㊷ ㊸×1
OT-85	Spur Gear	㊹ ㊺×1
OT-86	Counter Gear	㊻×1
OT-87	Gear Shaft Set	㊼ ㊽×1 ㊾×2
OT-88	Protector Set	㊿ ① ②×1 ③×2 ④×6
OT-93	Bumper	⑤×1
OT-95	Plate Set	⑥ ⑦ ⑧×1
OT-97	Sus. Shaft Set	⑨ ⑩ ⑪ ⑫×2
OT-98	Battery Holder Set	⑬ ⑭ ⑮ ⑯×1 ⑰ ⑱ ⑲ ⑳×2
OT-99	Wing Stay Set	㉑ ㉒×1 ㉓ ㉔×2 ㉕×4
OT-100	Collar Set	㉖ ㉗ ㉘×1 ㉙×2
OT-101	5.8 φ Ball (Black 2.6 φ)	㉚×10
OT-103	Tape Set	㉛ ㉜×2 ㉝×1
OT-107	Wing	㉞×1
OT-110	Rear Plate (L)	㉟×1
OT-120	Servo Saver Shaft	㊱ ㊲×2
OT-121	Narrow Wheel (Aero, dish, yellow)	㊳×2
OT-128	Main Chassis (FG)	㊴×1
OT-125	Body Set (C.Special)	㊵ ㊶×1
OT-126	Decal (")	㊷×1
OT-127	Screw Set (")	
OT-129	Linkage Set	㊸ ㊹×1
OT-131	5 φ Shim Set	㊺×20
OTW-2	Special Shock Stay	㊻ ㊼ ㊽×1
OTW-6	Upper Plate	㊾×1
OTW-7	Belt (254xL)	㊿×1
OTW-8	Belt Cover Set	① ② ③×1
OTW-9	Plastic Parts Set	④ ⑤ ⑥×1 ⑦ ⑧×2 ⑨ ⑩ ⑪×4
W-5001	Pressure Shock (S)	⑫ ⑬ ⑭ ⑮ ⑯ ⑰ ⑱ ⑲ ⑳ ㉑ ㉒ ㉓ ㉔×1 ㉕ ㉖ ㉗×4
W-5002	Pressure Shock (L)	⑳ ㉑ ㉒ ㉓ ㉔ ㉕ ㉖ ㉗ ㉘ ㉙ ㉚ ㉛ ㉜×1 ㉝ ㉞ ㉟×4
W-5005	Special Rod Set	㉞×2 ㉟ ㊱×4 ㊲×8 ㊳×12
W-5033		㊴×2
W-5061	Universal Swing Shaft	㊵×2
1840	Double Sided Tape	㊶×1
1878	Screw Cement	㊷×2
1889	Body Pin	㊸×5

No.	Parts Name	Key No. & Qty..
1903	4 φ x8 Bearing	㉑×2
1911	8 φ x14 Bearing	㉒×2
EF-37	Strap (S)	㉓×6
EF-39	NiCd Strap	㉔×6
EF-22	Hook Pin	㉕×5
UM-14	Servo Saver Set	㉖ ㉗ ㉘ ㉙ ㉚ ㉛×1 ㉜×2 ㉝ ㉞×4 ㉟×6
SD-79	Antenna Pipe	㊱×5
KC-20	E Ring (E4)	㊲×4
CB-72	E Ring (E3)	㊳×4
MA-17	Wheel (Low Profile, Yellow)	㊴×4
SG-25	Sprocket Set	㊵ ㊶×1 ㊷ ㊸×2
UM-43	Servo Saver, Strong Ring	㊹×2
1915	5 φ x8 Plain Bearing	㊺×10

Optional Parts

OT-47	Front Hub Set	Low Caster Type
OT-67	Wheel (Low Profile Tire)	3 Pieces Type x 2
OT-90	Wheel (Low Profile Tire)	One Piece Type x 4
FD-2	Wheel (Aero dish Yellow)	"
EF-103	Racing Wire	4 φ Silicon Cord
LM-15	Motor Cooling Set	Le Mans Motor, Cooling Plate
LM-18	Maintenance Kit	
RK-15	Low Profile Tire (Large block pattern)	Rear Tire x2
1863	Sponser Sticker	Decal Sponser Mark
1872	Sponge Tire (A)	Set-hard Surface Type
1883	Frontier Hobby Oil	30cc.
1951	Shock Oil Set (S,M,H)	Soft, Midium, Hard
1953	Silicon Oil (S)	Viscosity 100SC, 200SC x 1 (Same as 1951S)
1954	Silicon Oil (M)	Viscosity 300SC, 400SC x 1 (Same as 1951M)
1955	Silicon Oil (H)	Viscosity 500SC, 600SC x 1 (Same as 1951H)
1902	5 φ x8 Bearing	
W-0107	Ball Diff. (Front)	
W-0108	Ball Diff. (Rear)	
W-5003	Adjustable Shock (S)	Easy adjusting
W-5004	Adjustable Shock (L)	"
W-5021	Low Profile Wheel	Silver Plate 2 pcs.
W-5022	Narrow Wheel	" "
W-5023	Low Profile Wheel	Yellow 2 pcs.
W-5024	Narrow Wheel	" "
W-5031	Low Profile Tire (Hard)	For Hard Truck 2pcs.
W-5032	Low Profile Tire (Soft)	For Soft Truck 2pcs.
W-5034	Narrow Tire (Hard)	For Hard Truck 2pcs.
W-5075	Narrow Tire SS-M	Low Height Pin Spike 2pcs.
W-5076	Narrow Tire MH-M	Multi Spike 2pcs.
W-5077	Low Profile Tire SS-M	Low Height Pin Spike 2pcs.
W-5078	Low Profile Tire MH-M	Multi-Spike 2pcs.
W-5085	Hard Pinion Gear (15T-25T)	Hard Aluminum
W-5095		
1956	Silicon Oil (Super Hard)	Adjustable Oil for Diff.
OTW-1	Stabilizer Set	Stabilize the roll over.
OTW-5	Main Chassis (Carbon)	Tough chassis
OT-100		(17S)

The Super Hobby



'This products is not to be sold in the United States, If you have purchased this product in the United States, please contact Tom Miller at Kyosho U.S.A. phone number (217) 398-3630.'

PRINTED IN JAPAN

AAA 6T

OPTIMA MID

CUSTOM SPECIAL

EXPLODED VIEW

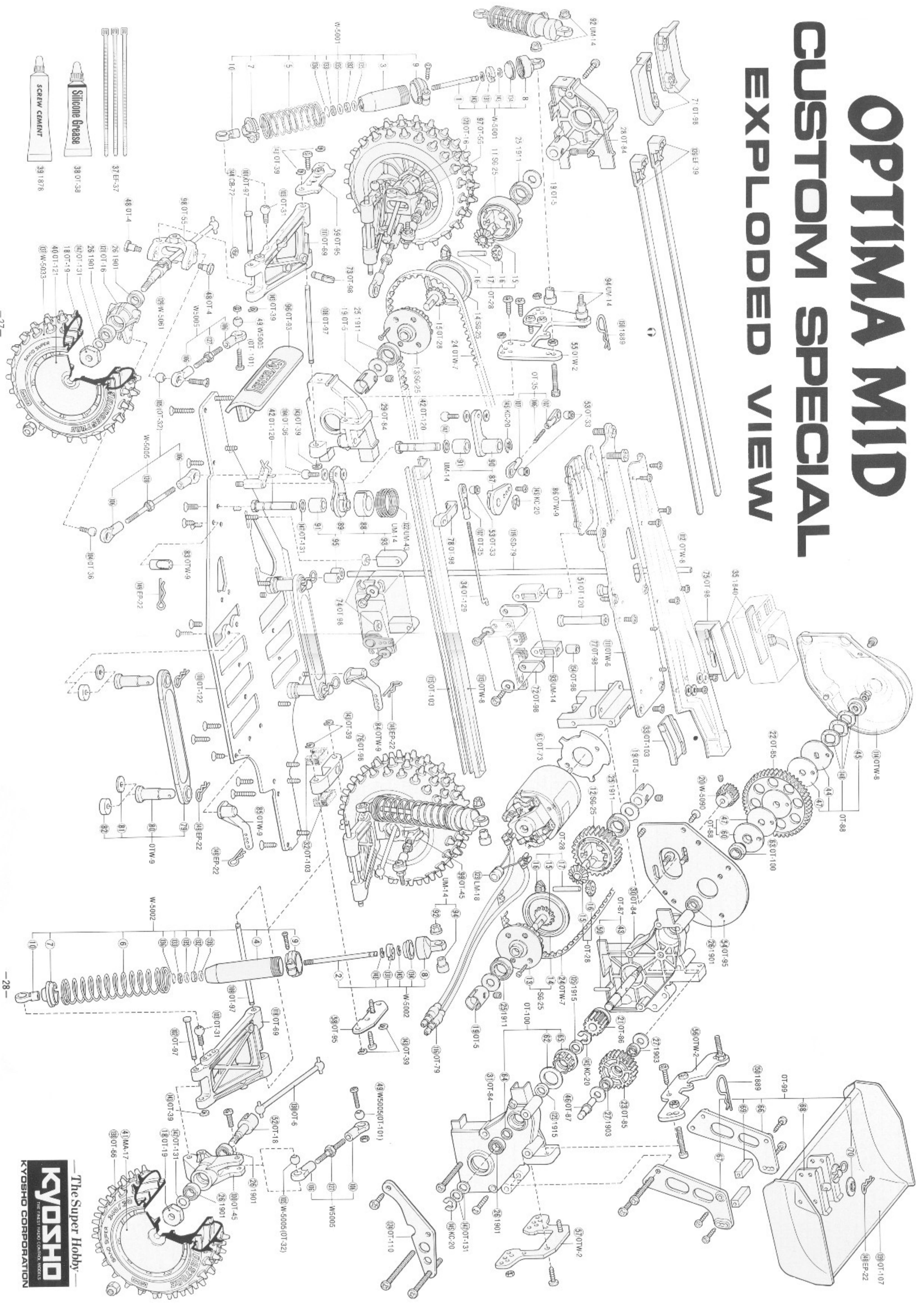

Silicone Grease
38 01-38

Screw Cement
39 18-76